

RSD START KIT

Product introduction

After a PV system has installed the component, a PV Analyzer is typically used to test the IV curve to ensure that the component is installed correctly. For components with APSMART RSD installed, the RSD START KIT needs to be concatenated in the system and tested with PV Analyze after the components are working properly.

Dimensions

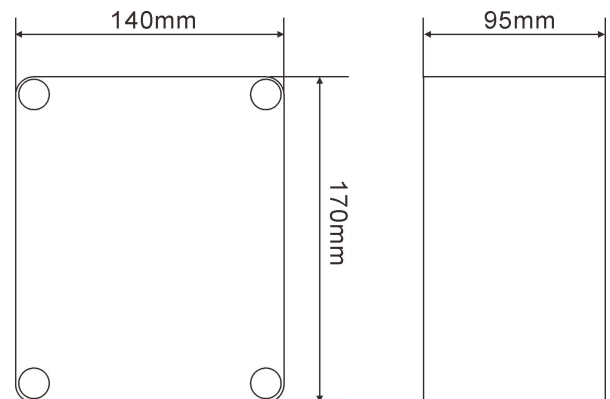

System installation drawing

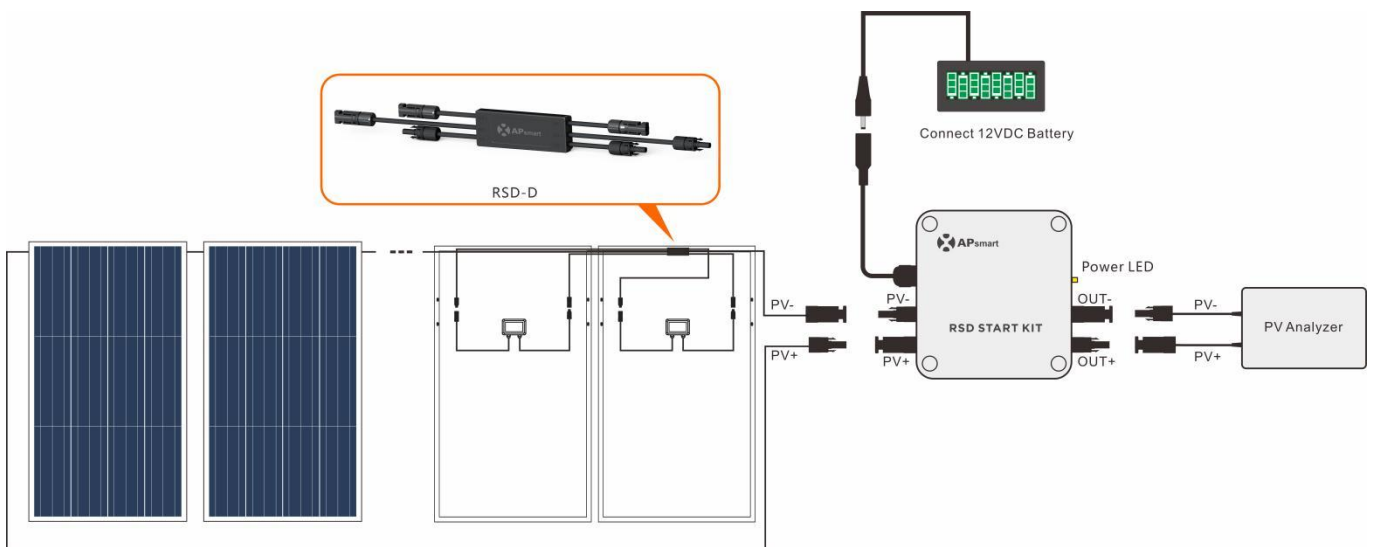



Steps for usage:

- ① As shown above, the RSD START KIT is concatenated between the component and the PV Analyzer.
- ② RSD START KIT is powered by a 12VDC battery case.
- ③ After the power indicator is turned on for 10 seconds, PV Analyzer is used for the test.

Datasheet

Input operating Voltage	12Vdc
Input operating Current	0.8A
Power supply interface	5.5×2.1mm DC Power Plug
Operating Ambient Temperature Range	-40°C-+60°C
Enclosure Rating	IP30
Dimensions (W x H x D)	125mmx125mmx75mm
Weight	550g

Ordering information

417000	RSD START KIT
--------	---------------

