

Pipe/Conduit Clamps & Hangers

Our beam attachments and pipe supports offered in this section are designed to provide supports without drilling or welding. A complete selection of beam clamps, pipe clamps, rollers, supports and accessories are designed for use with our channels and offer many installation advantages.

Materials & Finishes*

Pipe clamps, pipe hangers, beam clamps, brackets, and rollers are made from low carbon steel strips, plates or rod unless noted.

Finish Code	Finish	Specification
PLN	Plain	ASTM A1011 33,000 PSI min. yield
ZN	Electro-Plated Zinc	ASTM B633 SC3 Type III or ASTM A653
GRN	DURA-GREEN™	
DCU	DURA-COPPER™	
HDG	Hot-Dipped Galvanized	ASTM A123
YZN	Yellow Zinc Chromate	ASTM B633 SC3 Type II
SS4	Stainless Steel Type 304	ASTM A240
SS6	Stainless Steel Type 316	ASTM A240
AL	Aluminum	ASTM B209

*Unless otherwise noted.

Load Data

The load data published includes a safety factor of 5.0 unless noted (safety factor = ratio of ultimate load to the design load).

Recommended Torque For Setscrews (unless noted)

Setscrew Size	1/4"-20	3/8"-16	1/2"-13
Foot/Lbs.	4	5	11
Nm	5	7	15

Setscrew Size	5/8"-11	3/4"-10
Foot/Lbs.	21	34
Nm	28	46

*See chart on page 72 for bolt torque.

Metric

Metric dimensions are shown in parentheses. Unless noted, all metric dimensions are in millimeters.



B2207 THRU B2213 MULTI-GRIP PIPE CLAMPS FOR THINWALL (EMT), I.M.C., RIGID CONDUIT OR PIPE

- Safety Factor of 5
- Add PA to suffix for pre-assembled pipe clamps
- Includes Combination Recess Hex Head Machine Screw and Square Nut
- Material: ASTM A1011 33,000 PSI min. yield
- Standard finish: ZN

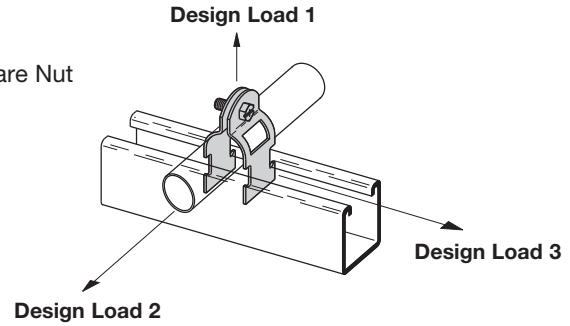

Part No.	Nominal Size		Material Thickness		O.D. Size Range		Alternate For Clamp No.'s	Design Load 1		Design Load 2		Design Load 3		Wt./C	
								Lbs.	kN	Lbs.	kg	Lbs.	kg	Lbs.	kg
B2207	3/8"	(10)	16 Ga.	(1.5)	.557-.706	(14.2-17.9)	B2000, B2001, B2026	400	(1.78)	50	(.22)	50	(.22)	9	(4.1)
B2208	1/2"	(15)	16 Ga.	(1.5)	.701-.875	(17.8-22.2)	B2001, B2008, B2027, B2028	400	(1.78)	50	(.22)	50	(.22)	11	(5.0)
B2209	3/4"	(20)	14 Ga.	(1.9)	.917-1.081	(23.2-27.4)	B2002, B2009,	400	(1.78)	50	(.22)	50	(.22)	12	(5.4)
B2210	1"	(25)	14 Ga.	(1.9)	1.125-1.375	(28.6-34.9)	B2003, B2010, B2030, B2031,	400	(1.78)	50	(.22)	50	(.22)	13	(5.9)
B2211	1 1/4"	(32)	14 Ga.	(1.9)	1.500-1.691	(38.1-42.9)	B2004, B2011, B2033, B2034	400	(1.78)	50	(.22)	50	(.22)	15	(6.8)
B2212	1 1/2"	(40)	12 Ga.	(2.6)	1.735-1.931	(44.0-49.0)	B2005, B2012, B2035	600	(2.67)	75	(.33)	75	(.33)	23	(10.4)
B2213	2"	(50)	12 Ga.	(2.6)	2.192-2.400	(55.7-60.9)	B2006, B2013 B2039	600	(2.67)	75	(.33)	75	(.33)	26	(11.8)

Pipe/Conduit Clamps & Hangers

BPC-8 THRU BPC-64 BREAK-APART CONDUIT CLAMP

- Design Load 200 Lbs. (.896 kN)
- Includes Combination Recess Hex Head Machine Screw
- Material: ASTM A1011 33,000 PSI min. yield
- Standard finish: ZN

Part No.	A Rigid or EMT Conduit Size		Wt./C	
			Lbs.	kg
BPC-8	1/2"	(21.3)	11.2	(5.1)
BPC-12	3/4"	(26.7)	12.7	(5.8)
BPC-16	1"	(33.4)	14.5	(6.6)
BPC-20	1 1/4"	(42.2)	16.5	(7.5)
BPC-24	1 1/2"	(48.3)	18.5	(8.4)
BPC-32	2"	(60.3)	21.5	(9.8)
BPC-40	2 1/2"	(73.0)	21.5	(9.8)
BPC-48	3"	(88.9)	22.0	(10.0)
BPC-56	3 1/2"	(101.6)	23.0	(10.4)
BPC-64	4"	(114.3)	27.5	(12.5)

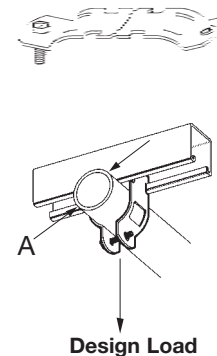

Reference page 126 for general fitting and standard finish specifications.