



Installation Guide

v3.7 (FRS-01/02)



FireRaptor

Solar Panel Rapid Shutdown

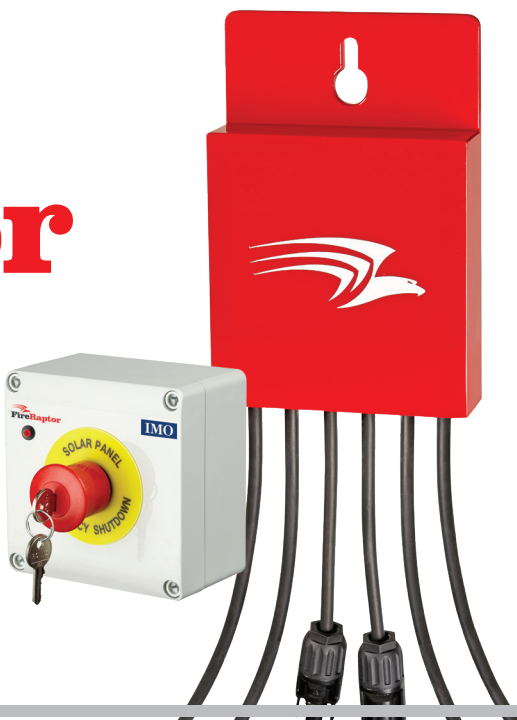

SAVE THESE INSTRUCTIONS - This manual contains important instructions for IMO Precision Controls Rapid Shutdown System Equipment that shall be followed during installation and maintenance of the Rapid Shutdown System Equipment, FRS-01, FRS-02, FRS-ESW1, FRS-ESW2, FRS-ESW1-K and FRS-ESW2-K.

DISCLAIMER

No part of this publication may be stored, reproduced or copied without prior written permission from IMO Precision Controls Ltd. The material furnished in this document is believed to be accurate and reliable however, IMO Precision Controls Ltd assumes no responsibility for the use of this material. IMO Precision Controls Ltd reserves the right to make changes to the information contained at any time without prior notice. All products and company names mentioned in this manual are trademarks or registered trademarks of their respective holders. The information contained herein is subject to change without prior notice for improvement.

FCC

This equipment has been tested and verified to be in compliance with the limits for FCC CFR47 part 15.107 Class B - Conducted Emissions and FCC CRF47 Part 15.109 Class B - Radiated Emissions, to provide reasonable to provide reasonable protection against harmful interference for unlicensed premises. This equipment generates and can radiate radio frequencies, and if not installed in accordance with the instructions, may cause interference with radio communications; should such interference occur then consider relocation of the product in order to increase the separation between the equipment.

Alterations not approved by the compliance authority may void the user’s authority to operate this equipment.

LIMITED WARRANTY

For Warranty Terms & Conditions go to <https://downloads.imopc.com/fire-raptor-limited-warranty.pdf>

CONTACT DETAILS

Please contact the below concerning technical questions about this product:-

United Kingdom	01707 414 444	imo@imopc.com
Australia / New Zealand	08 9302 5246	support@imopacific.com.au
Canada	905 799 9237	sales-na@imopc.com
USA	404 476 8810	sales-na@imopc.com
France	0800 912 712	imo-fr@imopc.com
Italy	800 930 872	imo-it@imopc.com
South Africa	021 551 1787	info@imopc.co.za
Rest Of The World	+44 (0)1707 414 444	imo@imopc.com

SAFETY SYMBOLS

Please contact the below concerning technical questions about this product:-



Warning - Failure to heed this the information indicated by this symbol may lead to dangerous conditions, possibly resulting in death or serious bodily injury.



Caution - Failure to heed this the information indicated by this symbol may lead to dangerous conditions, possibly resulting in minor or light bodily injuries and/or substantial property damage.



Information - Denotes important information about safety issues.



Note - Denotes additional information.

SAFETY INSTRUCTIONS



The FireRaptor is an electrical product and should only be installed by a suitably qualified person, in accordance with local regulations such as BS7671 (UK) and ANSI/NFPA70 (USA).



When modifying an existing installation, isolate the inverter from the PV array by turning OFF the DC isolator / switch disconnect or turn OFF the inverter and the AC switch.



PV Panel input and output connectors are not environmentally sealed until they are mated. Disconnected connectors should be plugged into an appropriate mating part or used with suitable watertight caps.



FireRaptor DC input and output connectors are not environmentally sealed until they are mated. Disconnected connectors should be plugged into an appropriate mating part (Tyco 282104-1 & 2pcs 282081-1 provided in FRS-ESW1/ FRS-ESW1-F / FRS-ESW1-K / FRS-ESW1-FK) or used with suitable watertight caps.



The IMO FireRaptor is fitted with Multi Contact MC4 (KBT4/KST4) connectors and to maintain UL connector approval listings these should only be mated with their counterpart connector. PV connectors should not be connected or disconnected under load.



Incorrect connections to the FireRaptor may cause failure.

CAUTIONS



Installation of the IMO FireRaptor without ensuring compatibility of the module/inverter connectors with the FireRaptor connectors may be unsafe and cause operational problems. For mechanical compatibility of the modules/inverter and the FireRaptor, use identical connectors from the same manufacturer on both the FireRaptor and modules, or obtain verification that the connectors to be used are compatible.



If the IMO FireRaptor is to be mounted directly to the PV frame or module, obtain guidance from the module manufacturer regarding its location and also verify the impact on the module warranty.

INTRODUCTION

The IMO Precision Controls FireRaptor product is Rapid Shut Down Equipment for connection to PV panel arrays in order to achieve compliance to 2014 NEC 690.12 and 2017 NEC 690.12.

The FireRaptor automatically shuts down array output to the PV inverter when it detects a temperature in excess to 85°C (FRS-01) and 92°C (FRS-02): this function was not evaluated by UL).

The FireRaptor can be installed without any set-up and with any string inverter as its functionality is completely independent. "Plug & Play" style installation using industry standard connectors makes the IMO FireRaptor suitable for new installations as well as retro-fit; and its mains powered independent DC power supply and emergency switch unit allows flexibility for positioning for user convenience giving Manual Emergency Shutdown, as well as responding to local or area grid shutdown.

PARTS

FRS-01	FireRaptor Rapid Shutdown System Unit
FRS-02	FireRaptor Rapid Shutdown System Unit with Fire Monitoring & Integration Options
FRS-ESW1	Emergency Rapid Shutdown Switch Unit (for FRS-01) - includes 24 VDC power supply
FRS-ESW2	Emergency Rapid Shutdown Switch Unit (for FRS-02) - includes 24 VDC power supply
FRS-ESW1-K	Emergency Rapid Shutdown Switch Unit with Key Lock (standard key) for FRS-01 - includes 24 VDC power supply
FRS-ESW2-K	Emergency Rapid Shutdown Switch Unit with Key Lock (standard key) for FRS-02 - includes 24 VDC power supply
FRS-ASW1	Auxiliary Emergency Rapid Shutdown Switch Unit (excludes 24 VDC power supply)
FRS-ASW1-K	Auxiliary Emergency Rapid Shutdown Switch Unit with Key Lock (excludes 24 VDC power supply)

INSTALLATION & CONNECTION

One FireRaptor will control two solar panels and for compliance with 2017 NEC it should be mounted within the array boundary of the two panels, where the two panels are no greater than 1' (foot) /30cm apart from each other.

Determine the mounting location of the FireRaptor (FRS-01 or FRS-02) and fix as shown below.

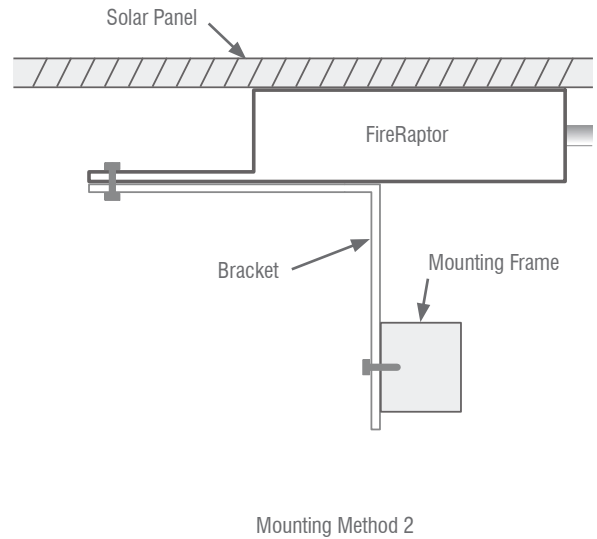
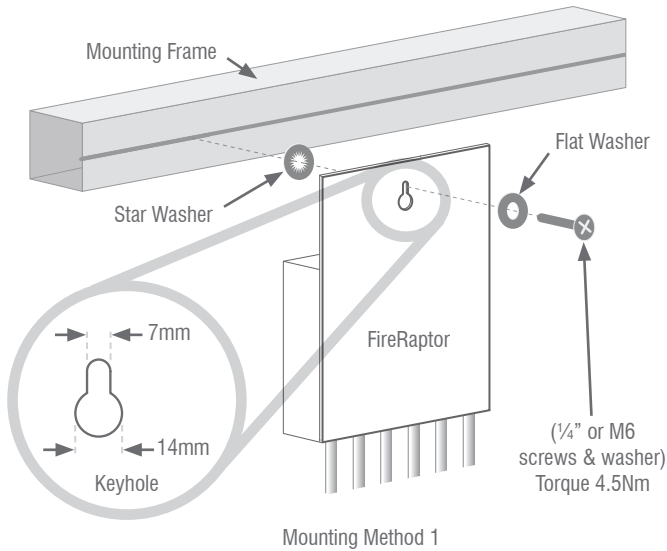

Do not drill through the FireRaptor as this will damage the unit and prevent operation.

Mounting Method 1 offers ease of fixing whilst Mounting Method 2 can be used where more effective use of the FireRaptor's onboard temperature sensing is required, by placing the FireRaptor in position against the underside of the PV panel (or the surface where the temperature needs to be sensed). Once mounted ensure that the FireRaptor is secure.



The FireRaptor is housed in a plastic enclosure therefore grounding of the product is unnecessary

FRS-01/FRS-02 INSTALLATION

Normal installation of FRS-01 / FRS-02 will be the connection of two PV panels in series to one FRS unit (typical wiring example below). Where the combined rating of two panels exceeds the rating of the FRS-01 / FRS-02, or to meet regulatory compliance, 1-to-1 connection of the PV module to the FireRaptor can be used. See diagram on page 5. Connect the array Positive (+) output connector to the FireRaptor Positive (+) input connector. Connect the array Negative (-) output connector to the FireRaptor Negative (-) input connector.

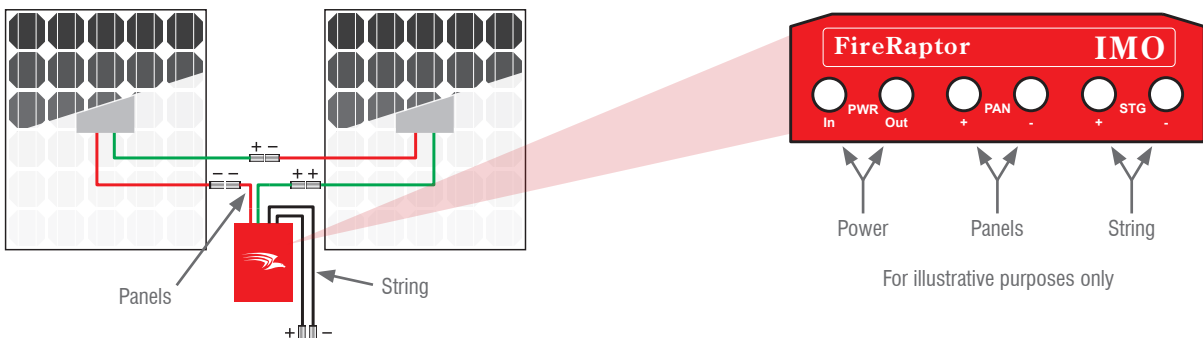

Connect the FireRaptor's two output cables to the DC isolator/Solar Inverter ensuring that the correct polarity is maintained throughout the electrical wiring.



For NEC 2017/2020 compliance PV panels should be <40V for 2-to-1 wiring, and <80V for 1-to-1 wiring.



Single panels can also be connected to IMO FRS-01/02 units - ensure correct polarity of PV panel connections (- to - and + to +).



Warning - Ensure that you have identified the inputs correctly. The FireRaptor input cables are the shorter ones.



The FireRaptor is OFF giving no array output until such time as the external DC power supply is energised and the Emergency Switch is in its non-activated position.

EMERGENCY RAPID SHUTDOWN SWITCH INSTALLATION

The Emergency Rapid Shutdown Switch Unit (FRS-ESW1 / FRS-ESW2 / FRS-ESW1-K / FRS-ESW2-K) hereafter referred to as FRS-ESW1, for installation; can be conveniently located anywhere for emergency access and is supplied with an internal 24VDC power supply to interface with the FireRaptor units.

Locate a convenient position for mounting the FRS-ESW1 unit ensuring that mains power connection is also available. Before mounting ensure that the cable entry/exit gland positions are accessible.

Remove the FRS-ESW1 cover taking care not to damage the switch or power supply contained within the FRS-ESW1 enclosure. Insert cable glands (supplied) into position, ensuring that the sealing washer (where supplied) is between the main gland body and the outer enclosure surface, screw the gland into position and then tighten securing/locking nut.

(n) The FRS-ESW1 should be connected in accordance with local wiring regulations (e.g. IET for UK, NEC for USA, CEC for Canada).

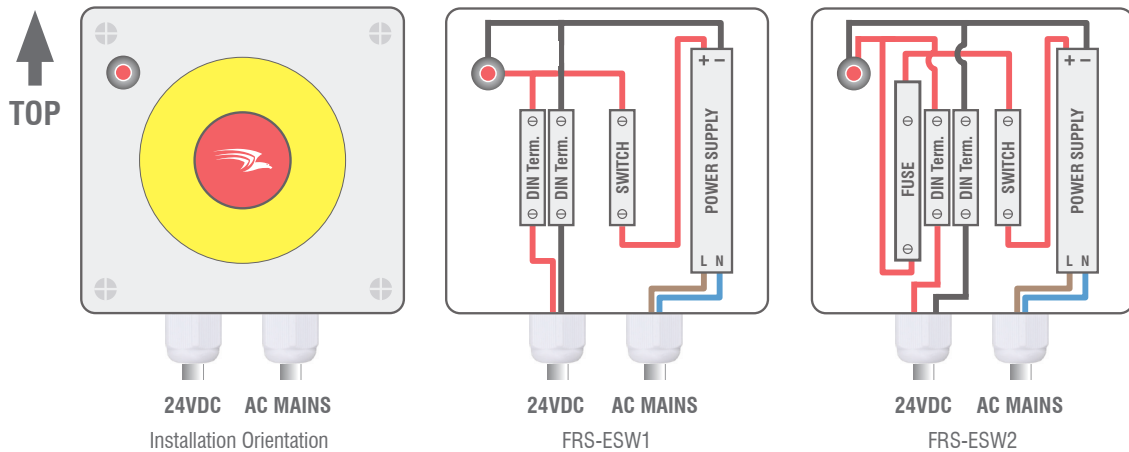

Using appropriate fixings attach the FRS-ESW1 unit vertically to the chosen surface.

(Δ) Mounting the FRS-ESW1 non-vertically will invalidate warranty.

Connect the mains supply wire to the FRS-ESW1 power supply L and N (Live and Neutral) terminals using suitably rated 2-core cable (refer Technical Specifications section for electrical details) ensuring correct polarity of connections. Verify secureness of cables.

(i) Strip AC mains wire length 4-5mm. Terminal tightening torque 0.5Nm (4.5lb-in).

(n) Single panels can also be connected to IMO FRS-01/02 units - ensure correct polarity of PV panel connections (- to - and + to +). Unused PV connectors must be environmentally sealed

Connect suitably rated 2x1mm² cable, one wire to the black wired DIN terminal Negative (-) terminal and with other wire to the red wired DIN terminal; this will be 24VDC Positive (+) wire. Terminate the remote end with a Tyco SuperSeal 2-pole socket [TE 282080-1 superseal female connector with 2pcs TE 282110-1 Superseal 1.5mm crimp tab terminal and appropriate seal depending upon cable diameter TE 281934-4 (1.2-1.4mm) or TE 281934-2 (1.7-2.4mm) or TE281934-3 (2.5-3.3mm)] ensuring correct polarity of connections [Tyco connector: pin 1 Positive (+24VDC), pin 2 Negative (0VDC)].

Ensure Superseal connector and cable are protected by a suitable cable boot e.g. Copat 75553.

(i) Strip 24V DC wire length 10mm. DIN terminal tightening torque 0.5Nm (4.5lb-in).

(n) Do not remove wire links connected within the FRS-ESW1. Verify screw tightness in case of loosening in transit.

Connect the Tyco SuperSeal 2-pole socket (female) to the FireRaptor plug (male).

(⚠) **Warning** – When the PV array is exposed to light, it supplies a DC voltage to this equipment. Connect and disconnect DC input and DC output circuits individually. Do not turn ON mains voltage until installation of FRS-ESW1 is completed and verified.

Where reference has been made above to the use of the IMO FRS-ESW1 as the source of supply of the 24VDC, it can also be considered that power can be supplied to the FRS-01/02 RSS units by an alternative suitably rated UL Approved 24VDC Class II power supply (AC/DC or DC/DC types). This PSU should be used in conjunction with a shutdown initiator that ensures disconnection of the 24VDC supply upon operation, and for the FRS-02 the appropriate in-line fuse must also be installed in the 24VDC line.

As the supply of these parts are outside the scope of IMO we recommend that the device's instructions of use are fully understood and the necessary appropriate precautions made when using such parts; and that the correct 24V/0V polarity connections are made as indicated in this installation guide.

MULTIPLE INSTALLATIONS

One FireRaptor FRS-01 / FRS-02 will control two solar panels and by series connection of the FireRaptor, multiple solar panel pairs can be connected to form a greater capacity system. The diagram below illustrates a typical example of a FireRaptor protected installation using eight solar panels and four FRS-01 / FRS-02 FireRaptors.

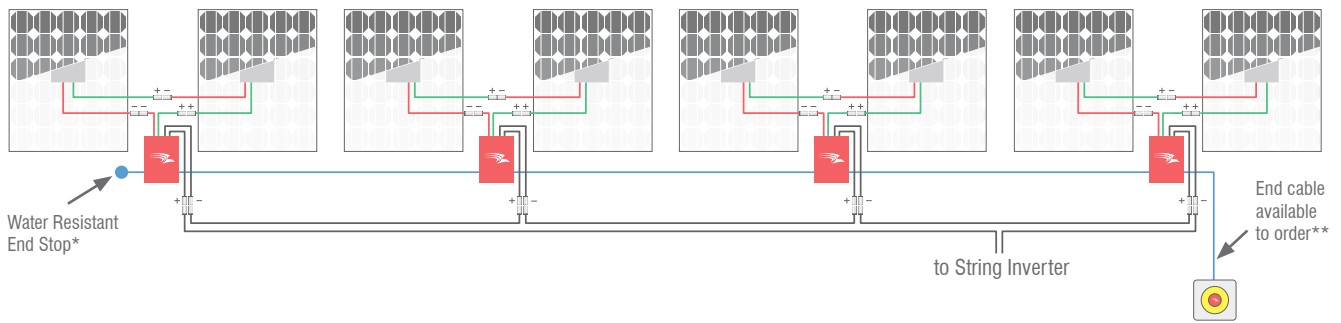

If the array has an odd number of panels, a single panel can be connected directly to the positive (+) and negative (-) panel cables of the FireRaptor. Also, the IMO FireRaptor system allows for multi-level/multi-zone installation through the use of an Emergency Switch Enclosure (FRS-ESW1 plus FRS-AWS1) connected in series with the initial Emergency Rapid Shutdown Switch's power supply Positive (+) wire 24VDC.

1-to-1 CONFIGURATION INSTALLATIONS (to meet local compliance)

Where the combined rating of two panels exceeds the rating of the FRS-01/FRS-02 in a 2-to-1 configuration (as shown in the diagram above) the FRS-01/FRS-02 should be utilized in a 1-to-1 configuration of one FireRaptor per PV module. 1-to-1 configuration may also be required in certain regions in order to meet regulatory compliance. The diagram below illustrates a typical 1-to-1 configured FireRaptor protected installation using six solar panels and six FRS-01 / FRS-02 FireRaptors.

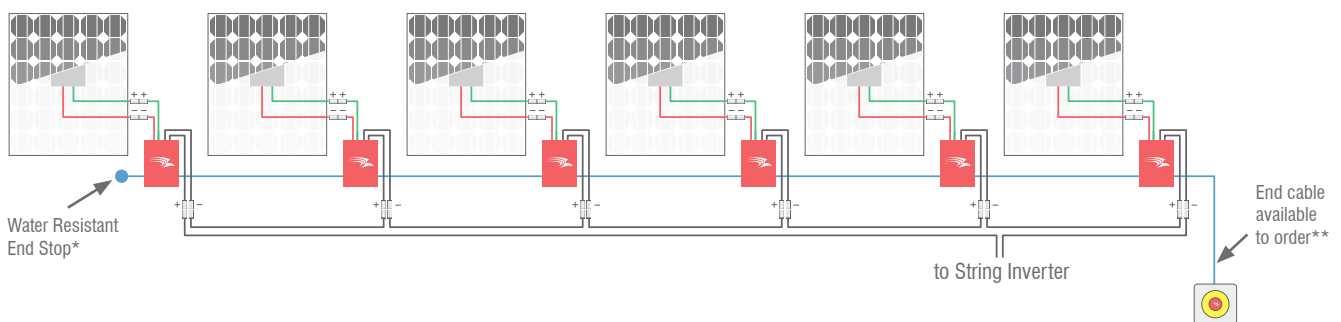

* Water resistant end stop - Insert the two red sealing plugs in to the Tyco Superseal plug (supplied) and connect to the DC output connector of the last FireRaptor (FRS-01/FRS-02) in the series installation. If only a single FireRaptor (FRS-01/FRS-02) is used then this part is still used to seal the DC output connector.

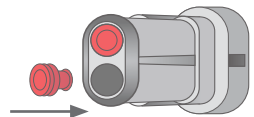

** A 1.8m flying lead terminated at one end with a Tyco female connector is available to order under part number FRS-SIGCAB1.8-F



Please ensure that cable voltage drops are considered when installing multiple FRS-01/02 units and/or 24VDC supply cable runs (please refer to IMO for more information).

OPERATION

Upon correct mounting and connection of the FireRaptor to the solar panels and the Emergency Shutdown Switch; and the turning ON of the mains supply, the FireRaptor will be operational.

1. Manual Shutdown

Upon the user operating the red push button switch located in the Emergency Switch Enclosure the FireRaptor performs a Rapid Shutdown, disabling the PV array output.

2. AC Supply Cut-Off Shutdown

Should there be a necessity by the emergency services for local or area utility grid shutdown, disconnection of the external AC supply, by whatever means, will cause the IMO FireRaptor to perform a Rapid Shutdown disabling the PV array output.

3. Automatic Emergency Shutdown

- Should the FireRaptor (FRS-01) onboard temperature sensor detect a temperature in excess of 85°C then the FireRaptor will instigate an Automatic Rapid Shutdown thereby disabling the PV module's output. Should the detected temperature then drop back to below 85°C, the FireRaptor will re-engage the PV module's output.
- In the event that the temperature sensor exceeds 92°C then the FireRaptor (FRS-01) will only re-engage the solar panels by a manual reset done via the Emergency Shutdown Switch (refer to point 4a below).
- With FireRaptor FRS-02, should the onboard temperature sensor detect an elevated temperature in excess of 92°C then, like point (a), the FRS-02 will instigate an Automatic Rapid Shutdown thereby disabling the PV string output. Operation will only be recommenced by a manual reset done via the Emergency Shutdown Switch (refer to point 4b below).

4. Reset

- On the occurrence of operation 1b (above) where the temperature sensor exceeds 92°C, once the area is deemed safe, the FireRaptor FRS-01 is reset by operating the Emergency Shutdown Switch and then releasing this switch.
- Upon occurrence of operation 1c (above), the installation and FireRaptor FRS-02 units must be checked by a competent person. Once the area is deemed safe then the FireRaptor is reset by replacement of the appropriate fuse within the FRS-ESW2/FRS-ESW2-K and then operating the Emergency Shutdown Switch and then releasing this switch.



The Emergency Shutdown Switch is a typical "one push" large red emergency push button which requires an anti-clockwise twist to release.



The FRS-ESW1 and FRS-ESW1-K includes an LED indicator which when used with FRS-01 signifies 24VDC power (ON) or power loss (OFF). The LED is not a status indicator as referred to in UL 1741 and does not indicate isolation of the PV field.



The FRS-ESW2 and FRS-ESW2-K includes an LED indicator which when used with FRS-02 signifies 24VDC power (ON), or power loss or trip (OFF). The LED is not a status indicator as referred to in UL 1741 and does not indicate isolation of the PV field.

TECHNICAL SPECIFICATION

	FRS-01/FRS-02
Emergency Shutdown Cable	2x1mm ² cable + Tyco SuperSeal 2-pole plug/connector (male/female)
DC Power Supply*	24VDC suitable for up to 20 FireRaptor units (40 panels)
Maximum System Input Power	700W single panel or 350W per panel (two panels in series)
Maximum System Input Voltage	150V single panel or 75V per panel (two panels in series)
Maximum System Input Current	12A
Maximum Isolation Voltage	1500V
Input Protection	Over voltage & transient voltage suppression
Maximum System Output Current	12A (99.5% efficiency)
Breakdown Voltage	1500VAC for 1 minute
Maximum System Output Voltage	150V
Output Protection	Over voltage, over current & transient voltage suppression
Max. Input Short Circuit Current	15A

Operating Temperature	-30°C to +95°C
Ambient Operating Temperature	-30°C to +55°C
IP Class Protection	>IP68 (NEMA 4X)
PV Casing	Flame retardant ABS - UL94-V0
Limited Warranty	FRS-0(X) : 20 Years, FRS-ESW(X)(-K) : 5 Years (See https://downloads.imopc.com/fireraptor-limited-warranty.pdf for terms)
Weight (without cables)	400g
Panel Cable Length	120mm
String & Signal Cable Length	1800mm
Standard Compliance	EN 61000, EN 61646, EN 61215, IEC 62716 draft C (NH ₃ resistant), VDE-AR-E 2100-712, BS 7671-712, UL 1741
PV Connectors	Multi contact MC4 (KBT4/KST4)

FRS-ESW1/2 Power Supply

Rated Input Voltage	90-264VAC
Rated Input Current (at I _o nom)	200mA (V _i 115VAC) / 135mA (V _i 230VAC)
Rated Input Frequency	47-63Hz
Input Fuse	T1A (250VAC)
Rated Output Voltage	24VDC
Rated Output Current	420mA
Rated Output Power	10W
Power Supply Connector Wiring	0.2 - 2.5 mm ² / AWG 26 - 12
Power Supply Torque	0.5 Nm / 4.5 lbin
DIN Terminal Connector Wiring	0.5 - 6 mm ² / AWG 26 - 10 (Note: FireRaptor uses Tyco connector 2x1mm ²)
DIN Terminal Torque	0.5 - 0.8 Nm / 4.5 - 7 lbin
Ambient Operating Temperature	-30 °C to +40 °C

* FRS-ESW1/FRE-ESW1-K Rapid Shutdown Switch can be upgraded to suit larger installations. Contact IMO for more details.

** FRS-ESW2/FRS-ESW2-K includes a 250V 500mA F fuse, replace only with fuse of the specified type, current and voltage. Contact IMO for more details.

TROUBLESHOOTING

Problem	Possible Cause	Possible Solution
Panel (pair) voltage is 0V	No mains supply (LED OFF)	Check area utility operational
		Check mains ON
		Check mains fuse
	FRS-ESW1 power supply failure (LED OFF)	Check mains voltage between L & N marked terminals
		Check 24VDC between + & - marked terminals
	FRS-ESW1 switch activated	Turn red actuator anti-clockwise to release button
	No FRS-ESW1 switch output (LED OFF)	Check 24VDC between switch out terminal & PSU – marked terminal
	Broken cable (LED OFF)	Check 24VDC between terminals of remote Tyco SuperSeal connector (pin 1 + 24VDC/pin 2 0VDC)
PV array not connected	Check all PV to FRS-01/FRS-02 input connections	
Incorrect FRS-01/FRS-02 polarity connection	Check PV array Positive (+) goes to FRS-01/FRS-02 Positive (+) and PV array Negative (-) goes to FFRS-01/FRS-02 Negative (-)	
No FRS-01/FRS-02 output	Replace FRS-01/FRS-02	
PV Inverter input 0V	No DC isolator (if fitted) input	Check FRS-01/FRS-02 output connections
		Check DC inputs to isolator
	DC Isolator (if fitted) OFF	Turn DC Isolator ON
String voltage too low	Incorrect FRS-01/FRS-02 polarity connection	Check all PV array Positive (+) go to FRS-01/FRS-02 Positive (+) and PV array Negative (-) go to FRS-01/FRS-02 Negative (-)

In the occurrence of a fire IMO recommend that all elements of the FireRaptor Rapid Shutdown system be assessed for operational suitability by a competent person prior to re-energising.