

# FLUSH MOUNT

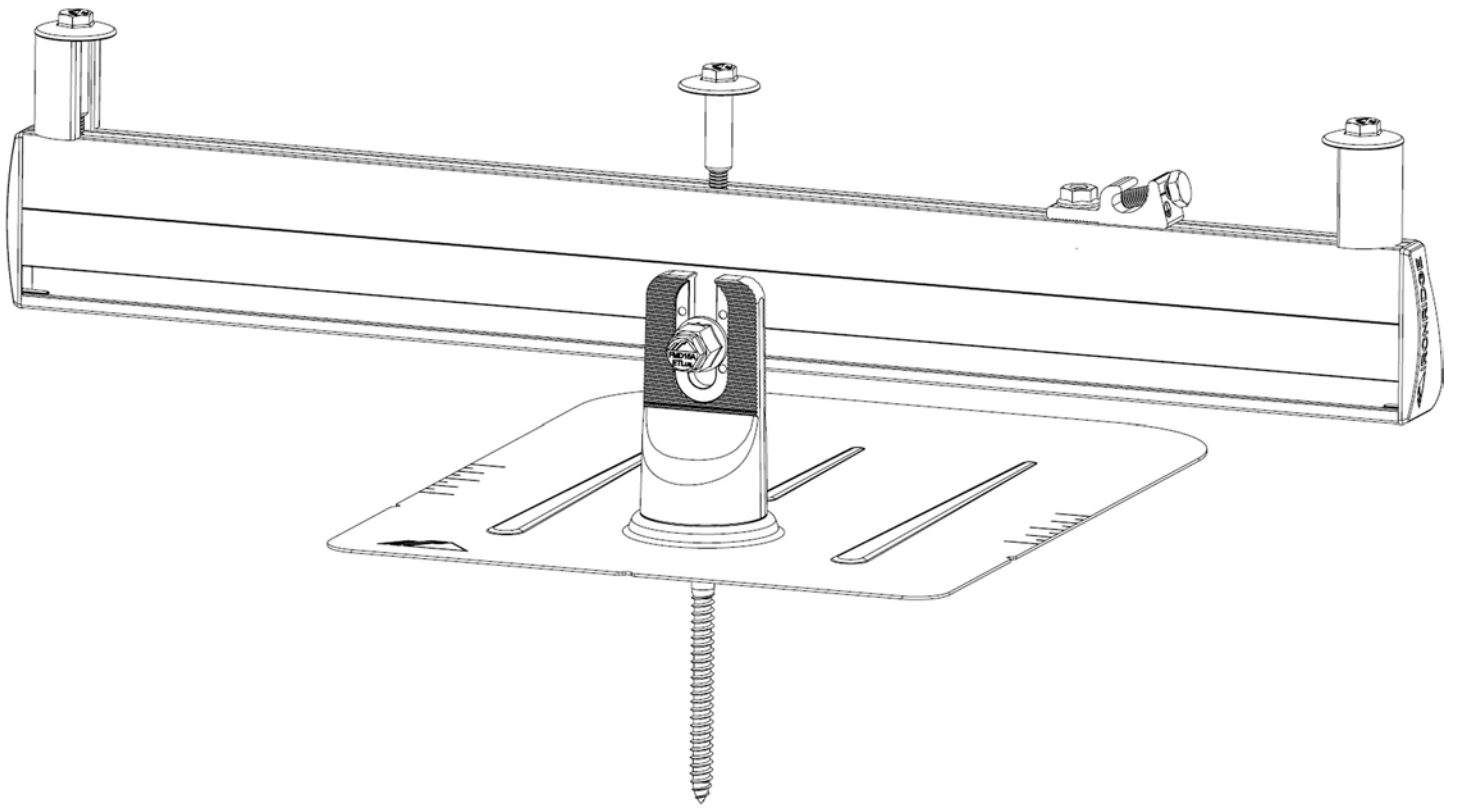

# CONTENTS

<b>DISCLAIMER</b>	<b>1</b>
<b>RATINGS</b>	<b>2</b>
<b>MARKINGS</b>	<b>2</b>
<b>ATTACHMENTS</b>	<b>3</b>
<b>COMPONENTS</b>	<b>4</b>
<b>1. ATTACH BASES</b>	<b>5</b>
<b>2. PLACE RAILS</b>	<b>5</b>
<b>3. SECURE LUGS</b>	<b>6</b>
<b>4. SECURE MODULES</b>	<b>6</b>
<b>CAMO</b>	<b>7</b>
<b>BONDING JUMPER</b>	<b>7</b>
<b>EXPANSION JOINTS</b>	<b>8</b>
<b>ELECTRICAL DIAGRAM</b>	<b>9</b>
<b>COMPOSITION SHINGLE</b>	<b>10-11</b>
<b>TILE</b>	<b>12-14</b>
<b>ADDITIONAL ROOF TYPES</b>	<b>14</b>
<b>LOW SLOPE ROOFS</b>	<b>15</b>
<b>CONDUIT PENETRATION</b>	<b>16</b>
<b>CONDUIT MOUNT</b>	<b>17</b>
<b>END CAPS</b>	<b>18</b>
<b>WIRE CLIPS</b>	<b>18</b>
<b>JAYBOX</b>	<b>18</b>
<b>MICROINVERTER KITS</b>	<b>19</b>
<b>SYSTEMS USING ENPHASE MICROINVERTERS OR SUNPOWER AC MODULES</b>	<b>19</b>
<b>SYSTEMS USING MICROSTORAGE PRODUCTS</b>	<b>20</b>
<b>FRAMELESS MODULE KITS</b>	<b>20</b>
<b>CONTOUR</b>	<b>21</b>
<b>MODULE COMPATIBILITY</b>	<b>22-27</b>
<b>FRAMELESS MODULE COMPATABILITY</b>	<b>27</b>

## DISCLAIMER

This manual describes proper installation procedures and provides necessary standards required for product reliability. Warranty details are [available on website](#). All installers must thoroughly read this manual and have a clear understanding of the installation procedures prior to installation. Failure to follow these guidelines may result in property damage, bodily injury or even death.

### IT IS THE INSTALLER'S RESPONSIBILITY TO:

- Ensure safe installation of all electrical aspects of the array. All electrical installation and procedures should be conducted by a licensed and bonded electrician or solar contractor. Routine maintenance of a module or panel shall not involve breaking or disturbing the bonding path of the system. All work must comply with national, state and local installation procedures, product and safety standards.
- Comply with all applicable local or national building and fire codes, including any that may supersede this manual.
- Ensure all products are appropriate for the installation, environment, and array under the site's loading conditions.
- Use only IronRidge parts or parts recommended by IronRidge; substituting parts may void any applicable warranty.
- Review the [Design Assistant](#) and [Certification Letters](#) to confirm design specifications.
- Ensure provided information is accurate. Issues resulting from inaccurate information are the installer's responsibility.
- Ensure bare copper grounding wire does not contact aluminum and zinc-plated steel components, to prevent risk of galvanic corrosion.
- If loose components or loose fasteners are found during periodic inspection, re-tighten immediately. Any components showing signs of corrosion or damage that compromise safety shall be replaced immediately.
- Provide an appropriate method of direct-to-earth grounding according to the latest edition of the National Electrical Code, including NEC 250: Grounding and Bonding, and NEC 690: Solar Photovoltaic Systems.
- Disconnect AC power before servicing or removing modules, AC modules, microinverters and power optimizers.
- Review module and any 3rd party manufacturer's documentation for compatibility and compliance with warranty terms and conditions.

## RATINGS

### UL 2703 LISTED



#### Conforms to STD UL 2703 Standard for Safety First Edition: Mounting Systems, Mounting Devices, Clamping/Retention Devices, and Ground Lugs for Use with Flat-Plate Photovoltaic Modules and Panels

- Max Overcurrent Protective Device (OCPD) Rating: 40A
- Max Module Size: 30.5 ft<sup>2</sup>
- Module Orientation: Portrait or Landscape
- System Design Load Rating: 10 PSF downward, 5 PSF upward, 5 PSF lateral
- Actual system structural capacity including spans and cantilevers are defined by PE stamped [certification letters](#).
- CAMO Specific Design Load rating: 50 PSF downward, 50 PSF upward, 15 PSF lateral

#### Certified to CSA TIL No. A-40 Photovoltaic Module Racking Systems

- Load Rating: 2400 PA [50 PSF]

#### CLASS A SYSTEM FIRE RATING PER UL 2703

- Any Roof Slope with Module Types 1, 2, 3, 13, 19, 25 & 29: Allowed with any roof slope. Any module-to-roof gap is permitted, with no perimeter guarding required.
- Module Type 5: Allowed with Steep Slope Roofs ( $\geq 9.5^\circ$ ). Any module-to-roof gap is permitted, low edge guarding (Trim) required
- Class A rated PV systems can be installed on Class A, B, and C roofs without affecting the roof fire rating

#### WATER SEAL RATINGS:

- UL 441 (Flashfoot2, All Tile Hook, Knockout Tile, Flashvue, L-Mount)
- TAS 100(A)-95 (Flashfoot2, All Tile Hook, Knockout Tile, Flashvue, L-Mount, Qbase)
- Tested and evaluated without sealant.
- Any roofing manufacturer approved sealant is allowed. Ratings applicable for roof slopes between 2:12 and 12:12

#### STRUCTURAL CERTIFICATION

- Designed and Certified for Compliance with the International Building Code & ASCE/SEI-7

#### FLORIDA PRODUCT APPROVAL #FL29843

- Conforms to TAS202, TAS100(A)
- Approved for installation both inside and outside High Velocity Hurricane Zones (HVHZ)
- Allowable design pressure up to +100/-100 PSF
- Additional details and full list of approved components can be found [Here](#).

## MARKINGS

Product markings are located on the Grounding Lug bolt head.

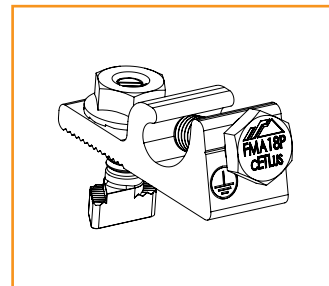
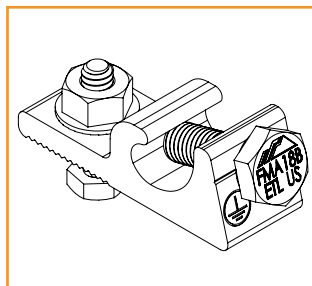

# ATTACHMENTS

## PRE-INSTALLATION

- ❑ Verify module compatibility. See [Page 21](#) for info.

## TOOLS REQUIRED

- ❑ Cordless Drill (non-impact)
- ❑ Impact Driver (for lag bolts)
- ❑ Torque Wrench (0-250 in-lbs)
- ❑ 7/16" Socket
- ❑ 1/2" Socket
- ❑ 9/16" Socket
- ❑ 7/32" Drill Bit
- ❑ 1/8" Drill Bit
- ❑ 1/4" Drill Bit
- ❑ T30 Bit
- ❑ Channel Lock Pliers
- ❑ #3 Phillips Bit
- ❑ 3/16" Hex Bit

## BONDING HARDWARE TORQUE VALUES

Please refer to each attachment's individual section for full details on all torque values and instructions.

- ❑ 3/8" Bonding Hardware Nuts (7/16" Socket): 250 in-lbs
- ❑ All Tile Hook Carriage Bolts (7/16" Socket): 132 in-lbs
- ❑ Flat Roof Attachment Nuts (9/16" Socket): 250 in-lbs
- ❑ Lynx Set Screw (3/16" Hex Drive): 150 in-lbs
- ❑ Lynx Flange Nut (1/2" Socket): 150 in-lbs

➤ If using previous version of Integrated Grounding Mid Clamps, End Clamps, Expansion Joints and for a list of approved 3rd party components please refer to Alternate Components Addendum (Version 1.9)

## ATTACHMENTS

### COMPOSITION SHINGLE



FlashFoot2

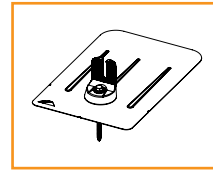

FlashVue

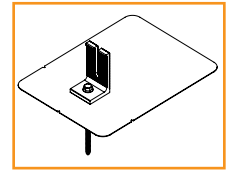

QM L-Mount

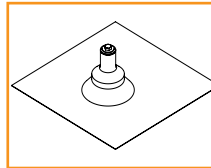

QM QBase

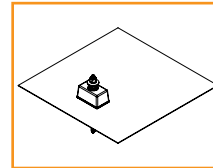

QM Classic Comp Mount

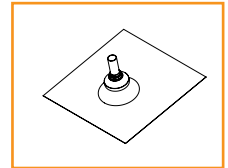

QM Composition Conduit Penetration

### TILE

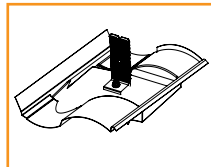

Knockout Tile

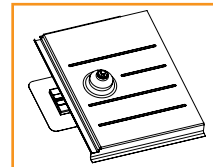

QM Tile Replacement

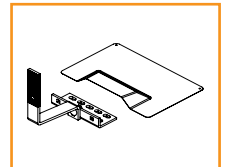

All Tile Hook and Flashing (optional)

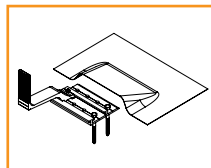

QM Quick Hook and Flashing (optional)

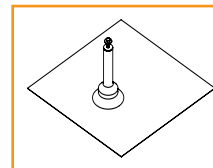

QM QBase Tile

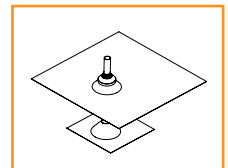

QM Tile Conduit Penetration

### ADDITIONAL ROOF TYPES

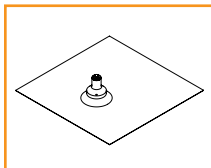

QM Qbase Shake - Slate - Metal Shingle

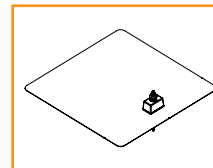

QM Classic Mount Shake

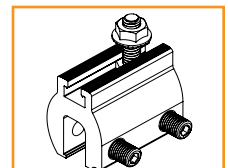

QM Lynx Metal Roof Attachment

### LOW SLOPE ROOF

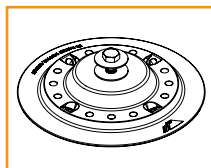

Flat Roof Attachment

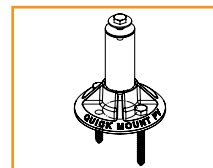

QM QBase Mount

# COMPONENTS

## PRE-INSTALLATION

- Verify module compatibility. See [Page 21](#) for info.

## TOOLS REQUIRED

- Cordless Drill (non-impact)
- Impact Driver (for lag bolts)
- Torque Wrench (0-250 in-lbs)
- 7/16" Socket
- 1/2" Socket
- 9/16" Socket
- 7/32" Drill bit
- 1/8" Drill bit
- 1/4" Drill bit
- T30 Torx Bit
- Channel Lock Pliers
- #3 Phillips Bit
- Paddle Bit

## BONDING HARDWARE TORQUE VALUES

Please refer to each attachment's individual section for full details on all torque values and instructions.

- Universal Fastening Object (7/16" Socket): 80 in-lbs
- Rail Grounding Lug Nut (7/16" Socket): 80 in-lbs
- Module Grounding Lug Nut (7/16" Socket): 60 in-lbs
  - Grounding Lug Terminal Screws (7/16" Socket): 20 in-lbs
- Expansion Joint Nuts (7/16" Socket): 80 in-lbs
- Microinverter Kit Nuts (7/16" Socket): 80 in-lbs
- Frameless Module Kit Nuts (7/16" Socket): 80 in-lbs
- 3/8" Bonding Hardware Nuts (7/16" Socket): 250 in-lbs
- Contour Clamp (T-30 Torx Bit): 80 in-lbs

► Unless otherwise noted, all components have been evaluated for multiple use. They can be uninstalled and reinstalled in the same or new location.

## COMPONENTS



XR Rail



Wire Clip

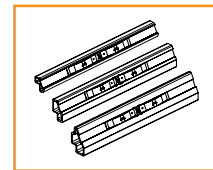

BOSS

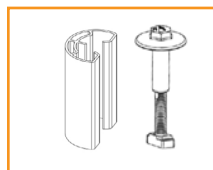

UFO and Stopper Sleeve (30-46MM)



CAMO

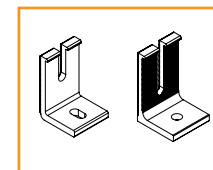

Ironridge L-Foot and QM L-Foot



End Cap

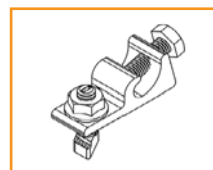

Rail Grounding Lug

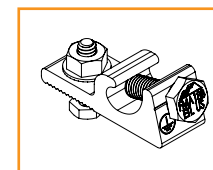

Module Grounding Lug

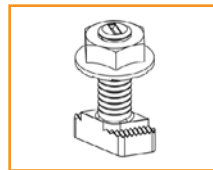

Microinverter Kit

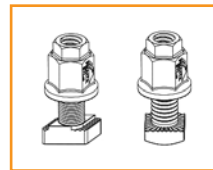

3/8" Bonding Hardware

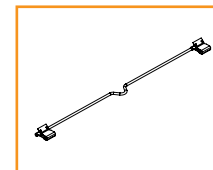

8" Bonding Jumper Single Use Only

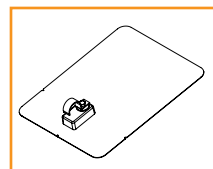

QM Classic Conduit Comp Mount

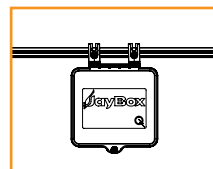

JAYBOX

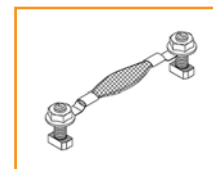

Expansion Joint

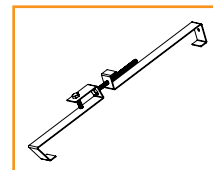

QM Tile Conduit Mount



Frameless End/Mid Clamp

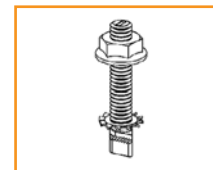

Frameless Module Kit

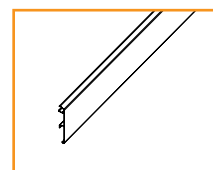

Contour Trim

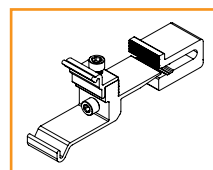

Contour Clamp

# 1. PLACE ATTACHMENTS

The general installation method for attachments is to locate a rafter, drill a pilot hole and install the attachment. For composition roof attachments installation instructions refer to [page 10](#). For tile roof attachments refer to [page 12](#). For low slope roof attachments refer to [page 14](#). When using approved third party attachments, refer to manufacturer's install instructions.

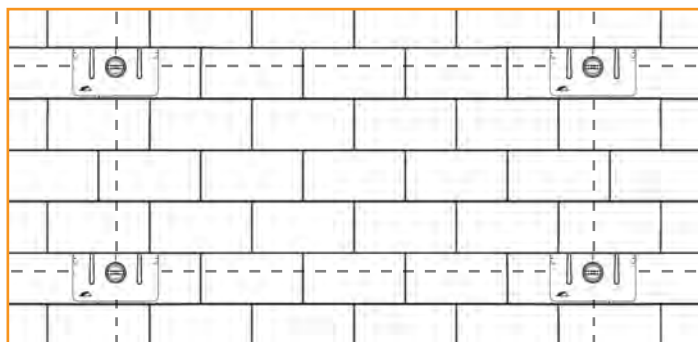

Tested or evaluated third-party roof attachments:

- [S-5! Standing Seam Metal Roof Clamps](#) - Certification of metal roof clamps includes bonding to both painted and galvalume metal roofs. Tighten S-5! and S-5! Mini set screws to 130-150 in-lbs ( $\geq 24$  gauge) or 160-180 in-lbs (22 gauge) roofs. Tighten S-5! M10 bolt to 240 in-lbs or S-5! Mini M8 bolt to 160 in-lbs. Use the following fastening guidelines for other S-5! roof clamps: ProteaBracket™ - firmly seat roof screws and tighten hinge bolt to 225 in-lbs; RibBracket™ - firmly seat roof screws and tighten M8 bolt (M8-1.25 x 22mm sold separately) to 160 in-lbs; and SolarFoot™ - firmly seat roof screws and tighten M8 flange nut to 160 in-lbs.
- [EcoFasten Green Fasten GF-1 Anchors](#)

# 2. PLACE RAILS

## A. CONNECT SPLICES

Use BOSS (Bonded Structural Splice), as needed, to join multiple sections of Rail.

### **BOSS - Bonded Structural Splice**

Insert BOSS into first Rail up until the Stop Tab. Slide second Rail fully into place.

- Rows using BOSS and exceeding 100 feet of Rail must use [Expansion Joints](#).
- Boss Splices may be installed in any location within a span.
- UFO and Bonding Hardware must be installed 1" away from the point where two Rails join together.

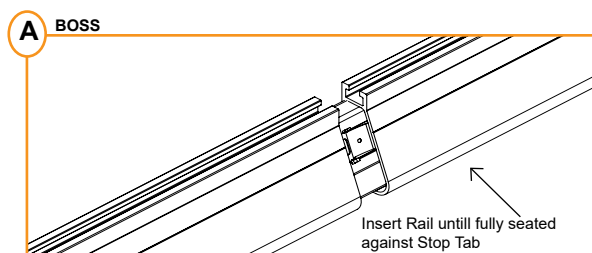

## B. PREPARE HARDWARE

Slide square-headed bolts into side-facing rail slot. Space out bolts to match attachment spacing.

- Tape ends of rail, to keep bolts from sliding out while moving.
- If using T-bolts, carry hardware onto roof and proceed.

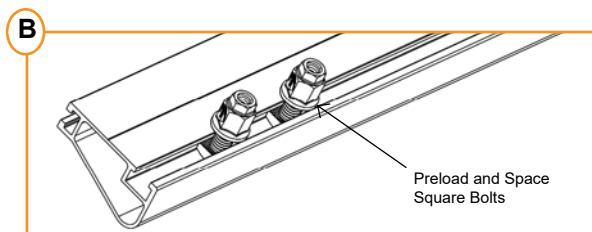

## C. ATTACH RAILS

Drop rail with hardware into roof attachment. Level rail at desired height, then torque to 250 in-lbs.

- Rail can face either upslope or downslope on roof.
- When using attachments with longer slots, do not install Rail lower than the top of the L-Foot to avoid damage to modules.

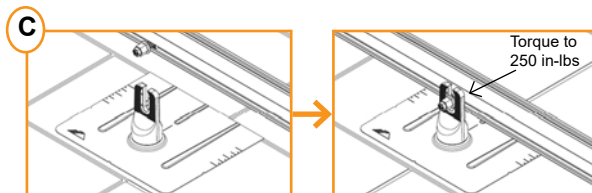

### 3. SECURE LUGS

#### Grounding Lugs

Only one Grounding Lug (Rail or Module) required per continuous subarray, regardless of subarray size (Unless frameless modules are used, see [Page 20](#)).

- **Grounding Lugs are intended to for use with one solid or stranded copper wire, conductor size 10-4 AWG.**

#### Rail Grounding Lug

Insert T-bolt in Top Rail slot and torque Hex Nut to **80 in-lbs**. Install a minimum 10 AWG solid copper or stranded grounding wire. Torque terminal screw to **20 in-lbs**.

- **Module Grounding Lugs can be installed anywhere along the Rail and in either orientation shown.**

#### Module Grounding Lug

Insert Bolt through Manufacturer approved grounding location and torque Hex nut to **60 in-lbs**. One Module Grounding Lug may be installed to one module per row. Install a minimum 10 AWG solid copper or stranded grounding wire. Torque terminal screw to **20 in-lbs**.

- **If using Enphase microinverters or Sunpower AC modules, Grounding Lugs may not be needed. See [Page 19](#) for more info.**
- **Refer to module manufacturer for mounting location and instructions.**

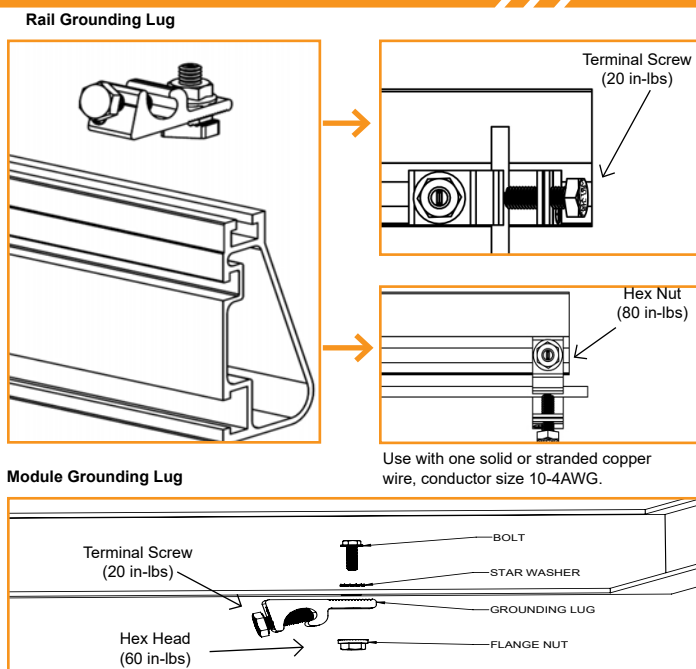

### 4. SECURE MODULES

#### A. SECURE FIRST END

Place first module in position on rails, a minimum of 1" from rail ends. Snap Stopper Sleeves onto UFO. Fasten module to rail using the UFO, ensuring that the UFO is hooked over the top of the module. Torque to **80 in-lbs**.

- **Ensure rails are square before placing modules.**
- **Hold Stopper Sleeves on end while torquing to prevent rotation.**
- **If using CAMO instead of UFO + Stopper Sleeve, refer to [Page 19](#) for CAMO installation procedure.**
- **UFO can be installed on modules 30 to 46mm.**

#### B. SECURE NEXT MODULES

Place UFO into each rail, placing them flush against first module. Slide second module against UFO. Torque to **80 in-lbs**. Repeat for each following module.

- **When reinstalling UFO, move modules a minimum of 1/16" so UFOs are in contact with a new section of module frame.**
- **When UFOs are loosened and re-tightened, ensure UFO T-bolt bottoms out in rail channel before re-torquing UFO to achieve full engagement between T-bolt and rail.**
- **If using Wire Clips, refer to [Page 18](#).**

#### C. SECURE LAST END

Place last module in position on rails, a minimum of 1" from rail ends. Snap Stopper Sleeves onto UFO. Secure UFO Clamps on rails, ensuring they are hooked over top of module. Torque to **80 in-lbs**.

- **Hold Stopper Sleeves on end while torquing to prevent rotation.**
- **Repeat all steps for each following row of modules, leaving a minimum 3/8" gap between rows**
- **If using CAMO instead of UFO + Stopper Sleeve, refer to [Page 6](#)**

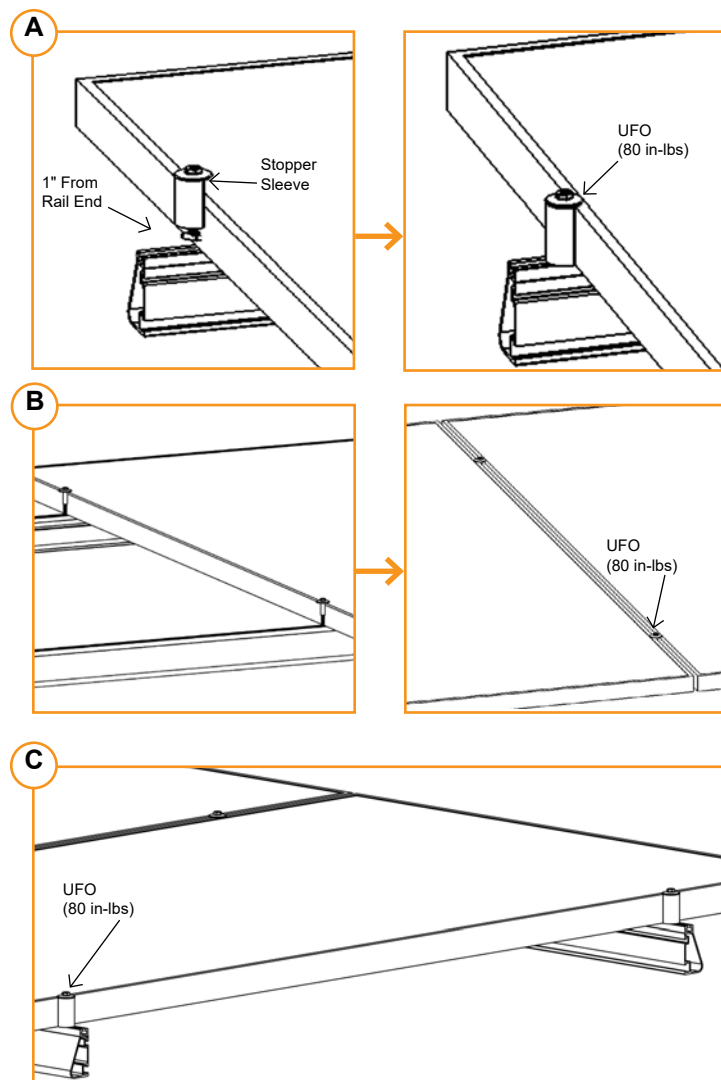

## CAMO

### A. SLIDE INTO RAIL

Slide CAMO into rail channel far enough to clear the module frame. CAMO requires 6" of clearance from end of rail.



### B. PLACE MODULE

Place module on rails (module cells not shown for clarity). When installing CAMO the module can overhang the rail no more than 1/4".

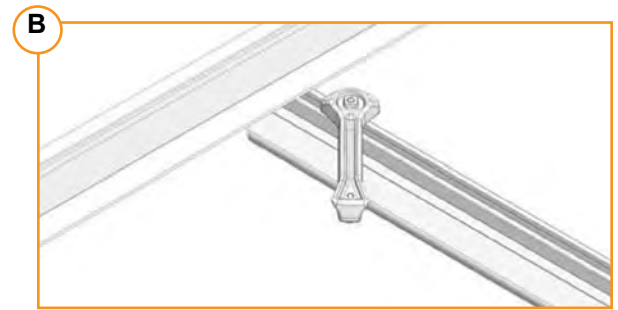

### C. PULL TOWARDS END

Pull CAMO towards rail ends, at 45 degree angle, so the bonding bolt contacts the module flange edge.

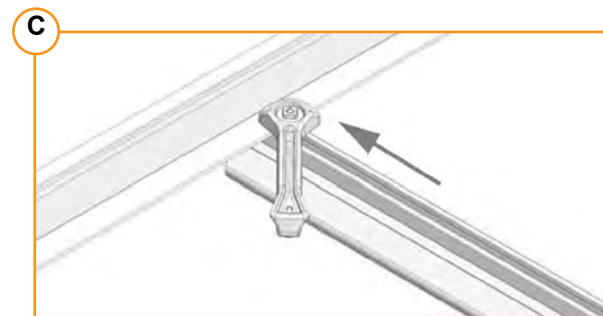

### D. SECURE TO FRAME

Rotate handle with an upwards motion until CAMO snaps into rail channel. Ensure CAMO bonding pins are fully seated on top of module frame.

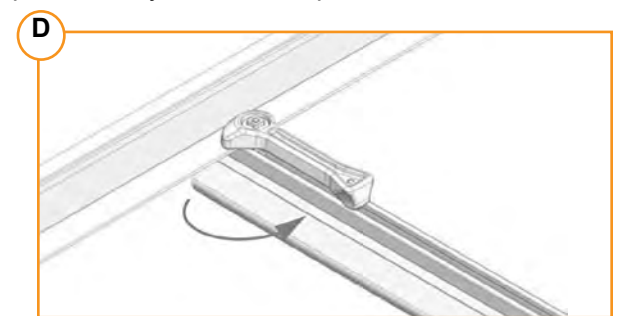

### FRAME COMPATIBILITY

CAMO has been tested or evaluated with all modules listed in the Module Compatibility section having frames within the referenced dimensions. Be sure the specific module being used meets the dimension requirements.

- For installations with Hanwha Q CELLS modules with 32 mm frame heights, the maximum ground snow is 45 PSF (33 PSF module pressure).
- CAMO is only compatible with Canadian Solar modules CS1YxxxMS and CS3N-xxxMS. "xxx" refers to the module power rating

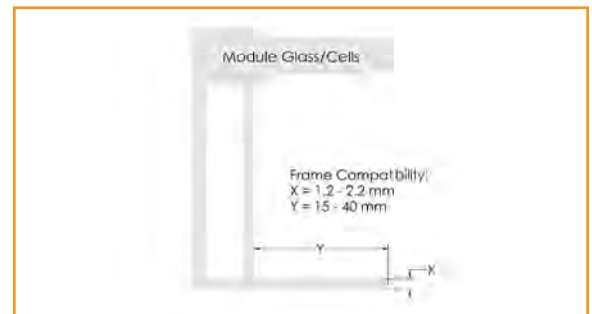

## 8" BONDING JUMPER

8" Bonding Jumper is an electrical bonding jumper that can be used on the Flush Mount System for row to row bonding; making the module frames the medium for the equipment ground path.

- Bonding jumper is pushed onto the bottom flange of the module.
- New jumpers should be used if re-installation of jumper is required.
- Supports bottom flange thicknesses from 1.2mm to 3.1mm.





## EXPANSION JOINTS

Expansion Joints are required every 100' of continuous rail to allow for thermal expansion and contraction of the system.

➤ Do not install modules over expansion joint.

### BOSS

Insert BOSS into first Rail up to the Alignment Circle, Slide second Rail over BOSS to the second Alignment Circle, leaving a 1" gap between the Rails.

There must be a 1" of space between the edge of the Rail and the edge of the panel to allow proper installation of the UFO and Stopper Sleeve.

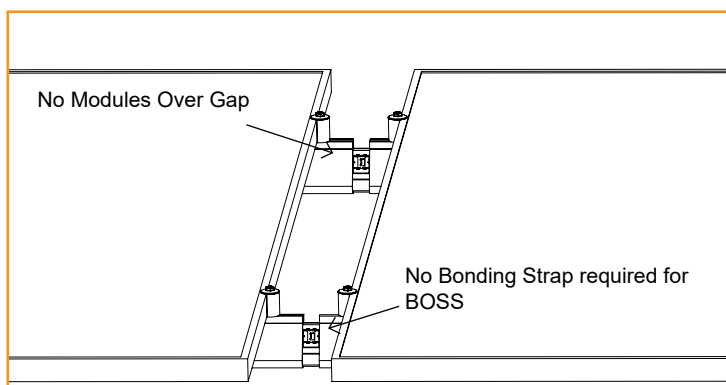
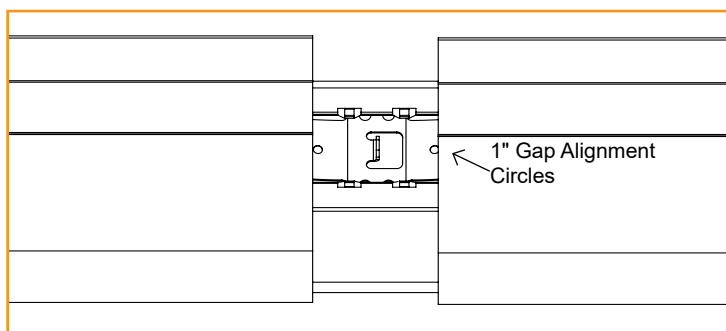
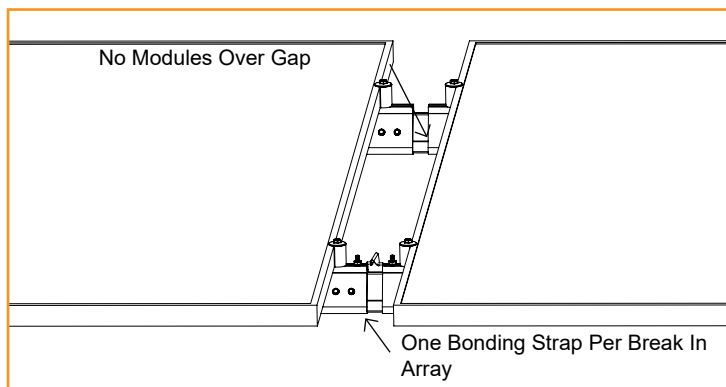

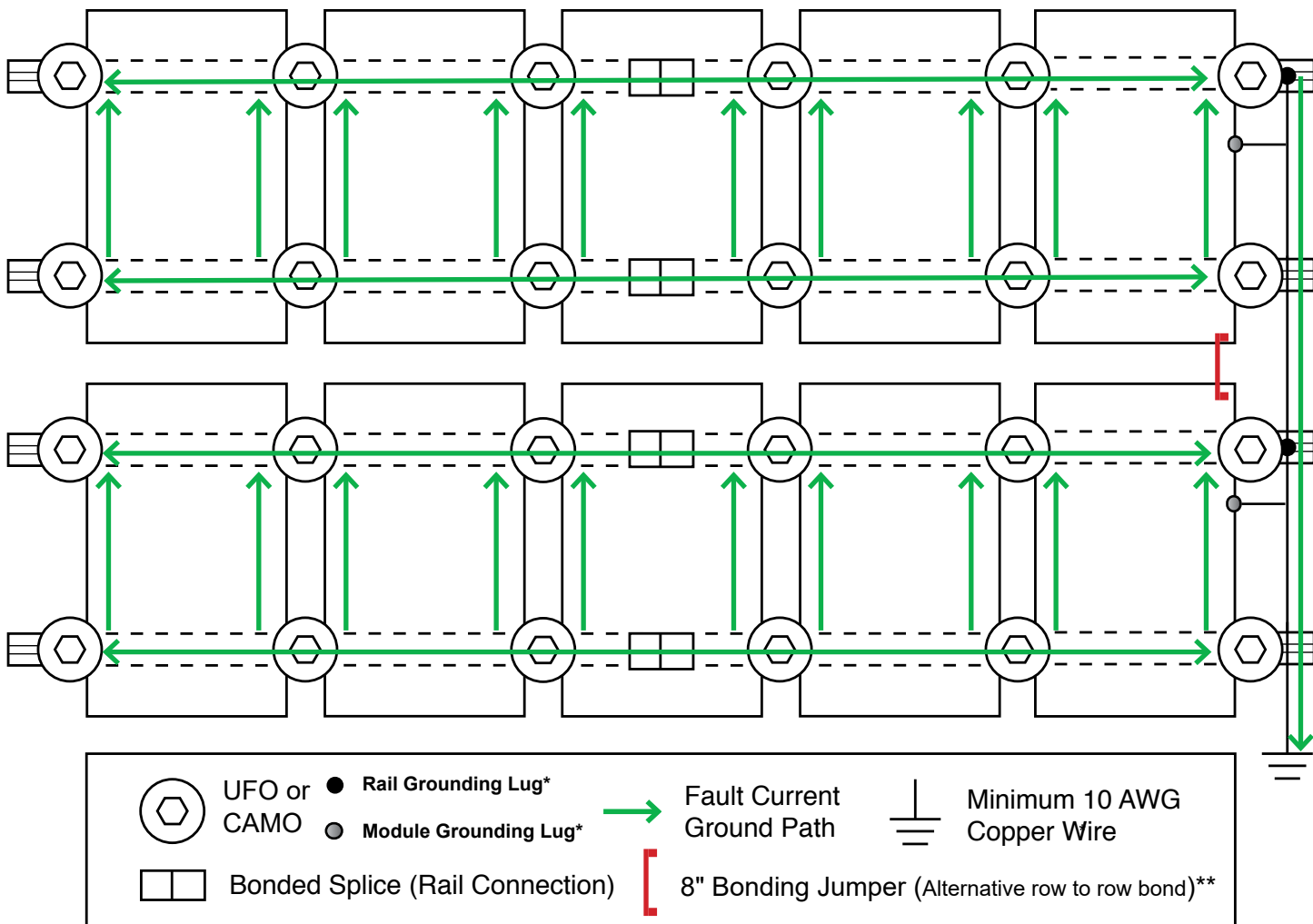

\*One Module Grounding Lug or Rail Grounding lug is required per row of a system.

\*\* The use of the 8" Bonding Jumper eliminates the need for row to row bonding. A minimum of one grounding lug per continuous array is required for earth ground.

Grounding Lugs and wire are not required in systems using certain Enphase microinverters or certain Sunpower modules. Equipment grounding is achieved with the Engage cable for Enphase or the AC module cable system for Sunpower via their integrated EGC.

## FLASHFOOT2

Locate roof rafters and mark locations on roof. Drill 1/4" pilot holes perpendicular to the roof and back fill with roofing manufacturers' approved sealant. Slide flashing between 1st and 2nd course of shingles, ensuring both that the flashing reaches under the 3rd shingle course and doesn't overhang the downhill shingle course. Line up with pilot hole and insert supplied lag bolt with washer through flashing. With a 7/16" Socket fully seat lag bolt. Place Cap onto flashing in desired orientation for E/W or N/S rails and rotate 180 degrees until it locks into place.

- Rail can be installed on either side of FlashFoot2 Cap.
- For additional details refer to the full FlashFoot2 [Installation Manual](#).

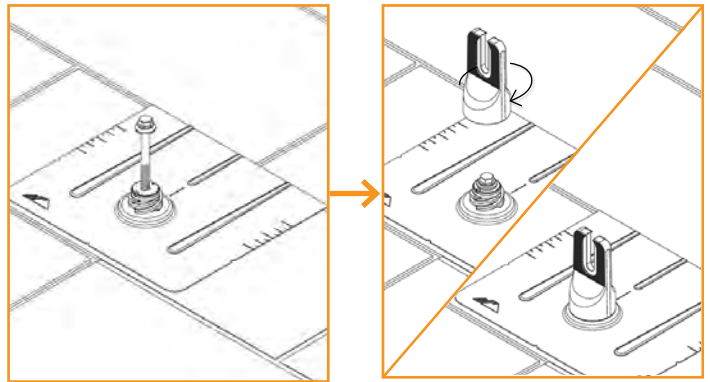

## FLASHVUE

Locate rafters and snap vertical and horizontal lines to mark locations of flashings. Drill 1/4" pilot holes, then backfill with an approved sealant. Slide flashing between 1st and 2nd course of shingles, ensuring both that the flashing reaches under the 3rd shingle course and doesn't overhang the downhill shingle course. Line up pilot hole with View Port. Press Grip Cap onto flashing in desired orientation for E/W or N/S rails. Insert Lag Bolt with mechanically bonded washer through flashing. With a 7/16" Socket drive Lag Bolt until fully seated. FlashVue is now installed and ready for IronRidge XR Rails. Attach rails to either side of the open slot using bonding hardware. Level rail at desired height, then torque to **250 in-lbs (21 ft-lbs)**.

When installing GripCap+ on roofs with undulations greater than 1 inch, install GripCap+ in low points across the array as required.

- For additional details refer to the full FlashVue [Installation Manual](#).
- For additional details on the GripCap+ refer to the full GripCap+ [Installation Manual](#).

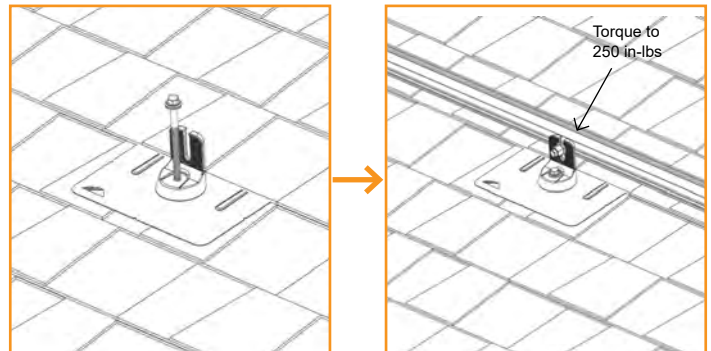

## COMPOSITION SHINGLE

### QM L-MOUNT

Locate roof rafters and mark locations on roof. Drill 7/32" (Lag) or 1/8" (ST) pilot holes perpendicular to the roof and back fill with roofing manufacturers' approved sealant. Slide flashing between 1st and 2nd course of shingles, ensuring both that the flashing reaches under the 3rd shingle course and doesn't overhang the downhill shingle course. Place L-foot on flute and rotate into desired position. Prepare lag bolt or structural screw with sealing washer. Use 1/2" socket to drive prepared lag bolt through L-foot until fully seated and L-foot can no longer rotate easily. Torque Nut to **156 in-lbs (13 ft-lbs)** for ST. Attach rail to L-Foot with Bonding Hardware and torque to **250 in-lbs (21 ft-lbs)**.

- Structural screw can be driven with T-30 hex head bit.
- For additional details refer to the full QM [Installation Manual](#).

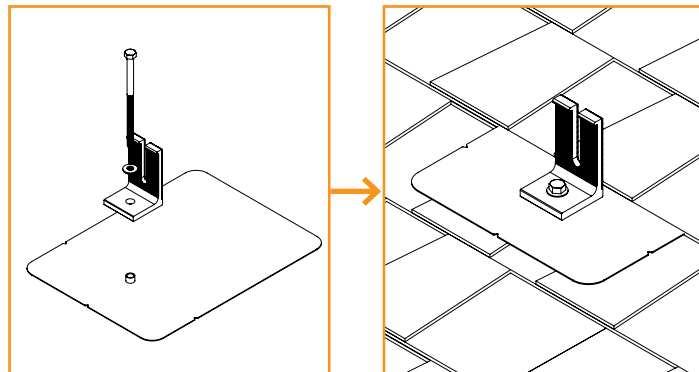

### QM QBASE COMPOSITION MOUNT

Locate roof rafters and mark locations on roof. Align QBase vertical holes over center rafter and mark. Drill two pilot holes with 7/32" drill bit, perpendicular to roof and back fill with roofing manufacturers' approved sealant. Set grade 8 cap screw through bottom of QBase, place QBase over drilled holes and secure lags. Screw Post to QBase. Proceed with roofing up until the flashing should be installed. Install flashing over mount. Allow roofing to proceed to the next course. Apply sealant where post and flashing meet, install EPDM counter flashing collar. Attach L-Foot on Standoff with hardware. Torque to **174 in-lbs (14.5 ft-lbs)**. Attach rail to L-Foot with Bonding Hardware and torque to **250 in-lbs (21 ft-lbs)**.

- For additional details refer to the full QM [Installation Manual](#).

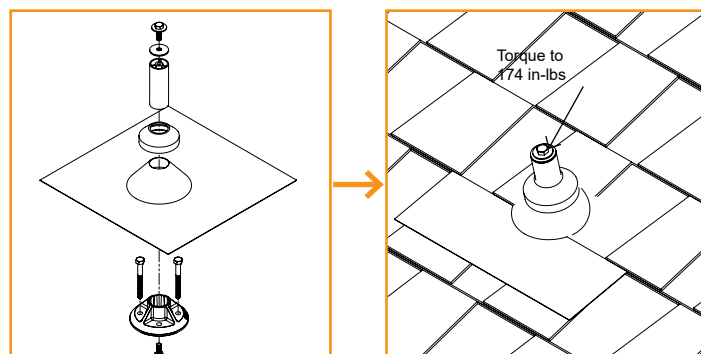

### CLASSIC COMP MOUNT

Locate roof rafters and mark locations on roof. Drill 7/32" pilot holes perpendicular to the roof and back fill with roofing manufacturers' approved sealant. Slide flashing between 1st and 2nd course of shingles, ensuring both that the flashing reaches under the 3rd shingle course and doesn't overhang the downhill shingle course. Prepare Hanger Bolt with Hex Nut and Sealing Washer, insert into hole and using 1/2" socket drive hanger bolt until fully seated and QBlock stops rotating easily. Insert EPDM rubber washer over hanger bolt into block, using Rack Kit hardware secure L-Foot to the mount. Torque to **156 in-lbs (13 ft-lbs)**. Attach rail to L-Foot with Bonding Hardware and torque to **250 in-lbs (21 ft-lbs)**.

- For additional details refer to the full QM [Installation Manual](#).

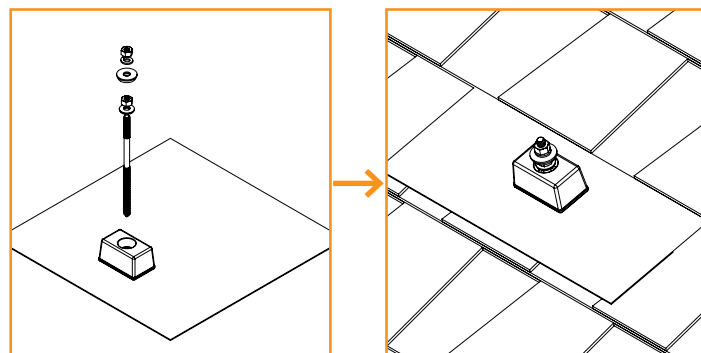

# TILE

## KNOCKOUT TILE

Remove tile and mark rafter. Use base as guide to drill 1/4" pilot hole and fill with roofing manufacturer's approved sealant. Install optional Roof Flashing and seal appropriately. Insert lag bolt with bonded washer through base (and flashing if used) and drive until fully seated. Insert Tile Replacement Flashing, lower onto base and apply pressure over the threaded post until it dimples the flashing. Place L-Foot over dimple and tap with hammer to punch threaded post through the flashing. Ensure punched pieces of flashing are cleared away. Form flashing as needed to sit flush with surrounding tiles, position L-Foot in desired orientation and torque hardware to **132 in-lbs (11 ft-lbs)**. Attach rail to L-Foot with Aire Dock and torque to **250 in-lbs (21 ft-lbs)**.

- Base can be installed in any orientation relative to rafter.
- Ensure L-Foot does not extend above rail.
- Optional deck level flashing is available. Standalone [installation manual](#) available on website
- Standalone [Knockout Tile manual](#) available on website.

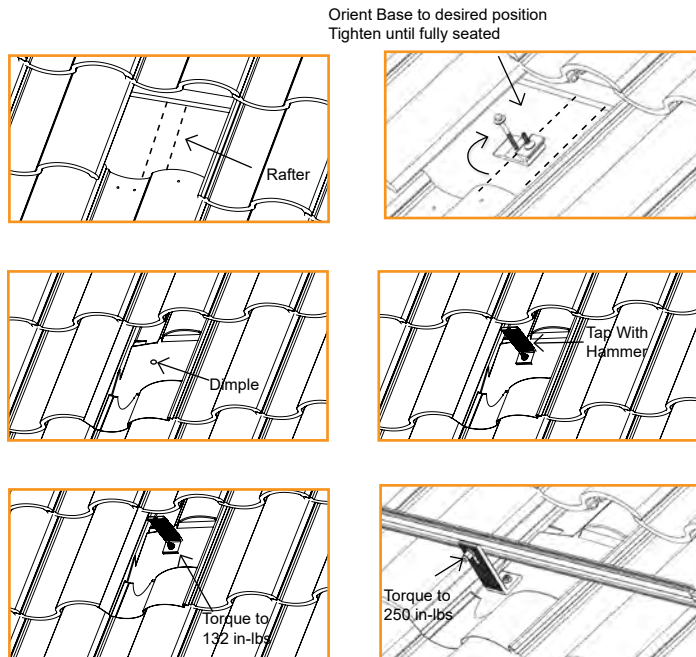

## QM TILE REPLACEMENT

Remove tile and mark rafter. Measure up 8 3/4" from the adjacent tiles and mark horizontal across rafter. Align baseplate over rafter so that the lag holes align with the post groove. The orientation of the plate can be adjusted cross roof, mark location of lag holes on the roof. Drill two 1/8" Pilot holes and back fill with roofing manufacturers' approved sealant. Waterproof at underlayment level according to roofing manufacturers' instructions and the Tile Roofing Industry Alliance guidelines. Use T-30 Torx bit to lag base into position. Insert Grade 8 Serrated Flange Bolt into bottom of the Post, slide Post into Base channel. Line up post with the hole in the Tile Replacement Flashing. Leave loose for adjustments. Place Tile Replacement Flashing over the Post and Mount, allowing the flashing to properly interlock with surrounding tiles. Secure Post by tightening with channel lock pliers. Replace all tiles. Apply a bead of sealant where the post meets the flashing, slip EPDM collar over post and down to flashing. Attach L-Foot on Standoff with hardware. Torque to **174 in-lbs (14.5 ft-lbs)**. Attach rail to L-Foot with Bonding Hardware and torque to **250 in-lbs (21 ft-lbs)**.

- If deck level flashing is required, approved flashing methods include user supplied adhesive backed flexible flashing.
- For additional details refer to the full QM [Installation Manual](#).

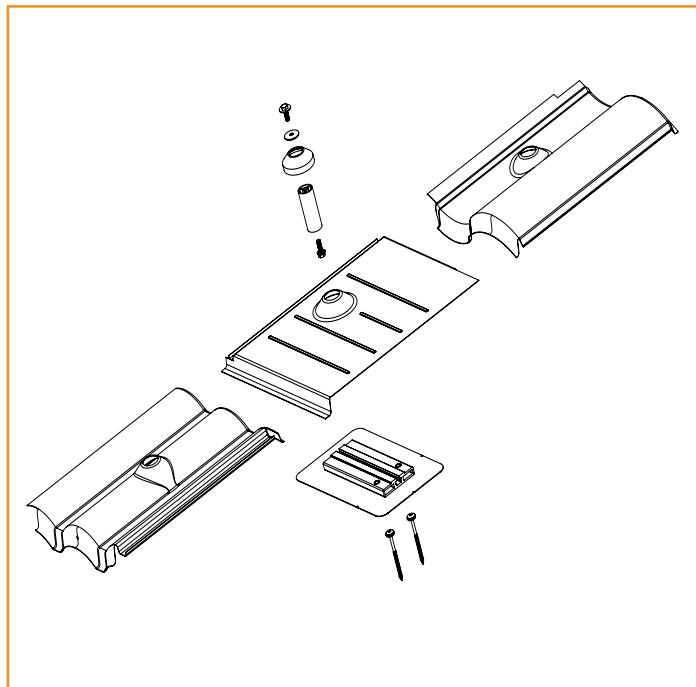

## ALL TILE HOOK

Remove tile and mark rafter. Position base over rafter, adjust arm if necessary and torque hardware to **132 in-lbs (11 ft-lbs)**. Use base as guide to drill 1/4" pilot holes, back fill with roofing manufacturer's approved sealant, then insert lag bolts and tighten until fully seated. Replace tiles and notch as necessary to ensure proper fit. Attach rails to either side of slot using Bonding Hardware and torque to **250 in-lbs (21-ft-lbs)**.

- Position arm near the center of valley for curved tiles.
- Position arm away from seam of joining flat tiles.
- Ensure top of hook does not extend above rail.
- Standalone [All Tile Hook manual](#) available on website.

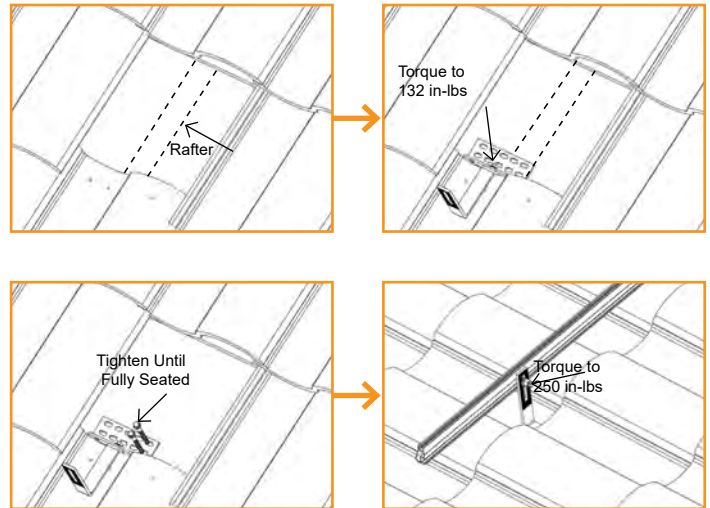

## QM QUICK HOOK

Remove tile and mark rafter, use Base Plate to mark two holes on rafter. Drill two 7/32" pilot holes and back fill with roofing manufacturers' approved sealant. Use 1/2" socket to drive lag into place. Slide hook into place and adjust to desired position. Drive self-tapping screw using a #3 Phillips bit to lock hook in place. Clean underlayment and apply a bead of sealant compatible with roofing manufacturer, install flashing over mount. Fasten sub-flashing to deck with one roofing nail in each corner. Waterproof at underlayment level according to roofing manufacturers' instructions and the Tile Roofing Industry Alliance guidelines. Cut clearance notch in the weather guard of tile as needed or utilize QM Tile Replacement Flashings. Attach rails to either side of slot using Bonding Hardware and torque to **250 in-lbs (21-ft-lbs)**.

- Position arm near the center of valley for curved tiles.
- Position arm away from seam of joining flat tiles.
- Ensure top of hook does not extend above rail.
- For additional details refer to the full QM [Installation Manual](#).

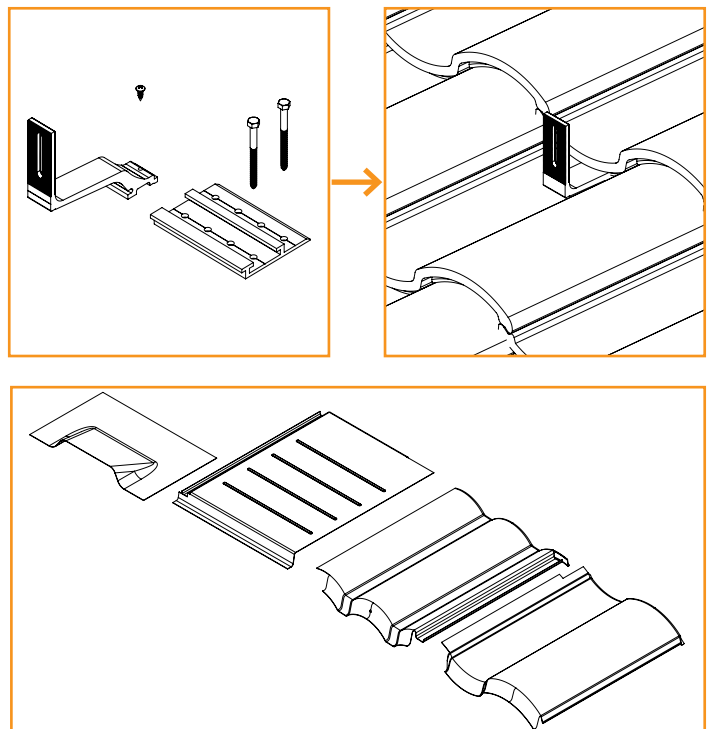

## TILE

### QM QBASE UNIVERSAL TILE MOUNT

Remove tile and mark rafter. Measure up 6 5/8" from bottom of tiles and mark horizontally. Align QBase over rafter center and drill two 7/32" pilot holes, back fill with roofing manufacturers' approved sealant. Place grade-8 Cap Screw under QBase, lag QBase into rafter location. Install Sub-flashing, waterproof at underlayment level according to roofing manufacturers' instructions and the Tile Roofing Industry Alliance guidelines. Cut tile with diamond blade to allow post to pass through. Place tile in position and then install Post. Install 18"x18" flashing, pre-bent to follow the contour of the tile as required. Apply sealant where Post and Flashing meet and install EPDM counter flashing. Attach L-Foot on Standoff with hardware. Torque to **174 in-lbs (14.5 ft-lbs)**. Attach rails to L-Foot using Bonding Hardware and torque to **250 in-lbs (21-ft-lbs)**.

➤ For additional details refer to the full QM [Installation Manual](#).

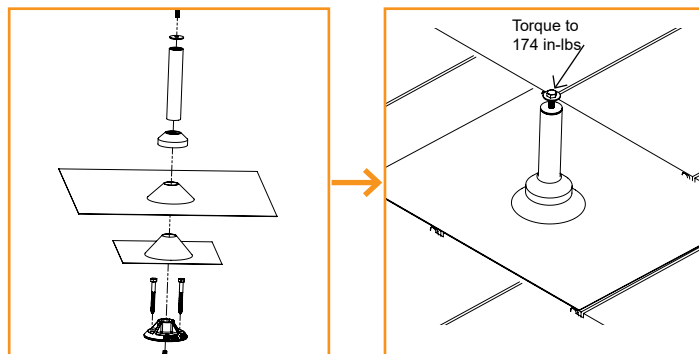

## ADDITIONAL ROOF TYPES

### QM CLASSIC SHAKE MOUNT

Locate roof rafters and mark locations on roof, remove shakes directly above mount if needed to expose felt paper. Level out installation area and location installation point, mark. Drill 7/32" pilot hole, back fill with roofing manufacturers' approved sealant. Prepare Hanger Bolt with Hex Nut and Sealing washer, insert into QBlock hole and drive into rafter until fully seated and the QBlock no longer swivels easily. Insert EPDM washer over hanger bolt and then install L-Foot in desired orientation and torque hardware to **132 in-lbs (11 ft-lbs)**. Attach rail to L-Foot with Bonding Hardware and torque to **250 in-lbs (21 ft-lbs)**.

➤ For additional details refer to the full QM [Installation Manual](#).

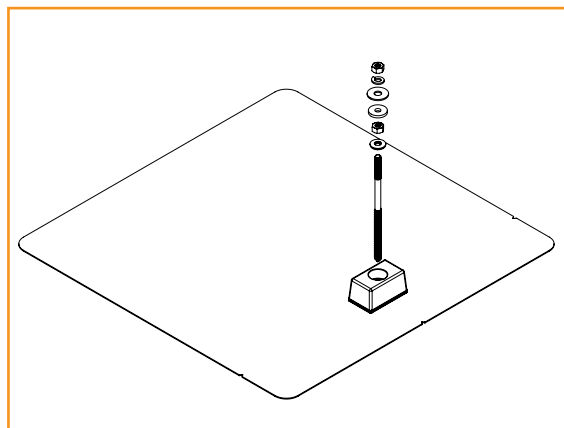

### QM QBASE METAL, SHAKE AND SLATE

The QM QBase can be used to install on multiple roofing types with different installation methods.

➤ For instructions on installing the QBase on Slate refer to the full QM [Installation Manual](#).

➤ For instructions on installing the QBase on Shake refer to the full QM [Installation Manual](#).

➤ For instructions on installing the QBase on Metal Shingle refer to the full QM [Installation Manual](#).

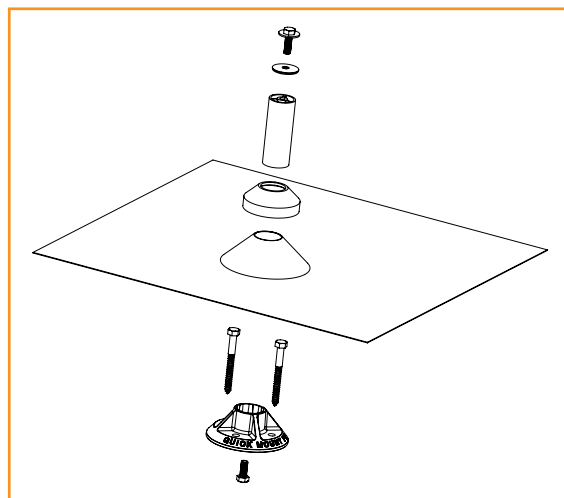

## LOW SLOPE ROOFS

### FLAT ROOF ATTACHMENT

Flat Roof Attachment can be used with an L-foot for flush mounting modules on low sloped roofs. Mark locations for Flat Roof Attachment. Screws should be installed symmetrically to each other. If using a membrane flashing, remove the silicone washer's protective liner prior to attaching the membrane. Attach L-foot with washers and 3/8" hardware torqued to **250 in-lbs (21 ft-lbs)**. Seal attachment and/or membrane per roofing manufacturer's requirements.

- **Type, size, and quantity of roof screws to be specified by Structural Engineer. Fastener size not to exceed #15.**
- **Membrane flashing available for TPO, PVC, and KEE roofs. Ensure membrane flashing is compatible with existing roofing material.**
- **If membrane flashing is not used, only washer on top of L-Foot is required.**
- Standalone [Flat Roof Attachment Manual](#) available on website.

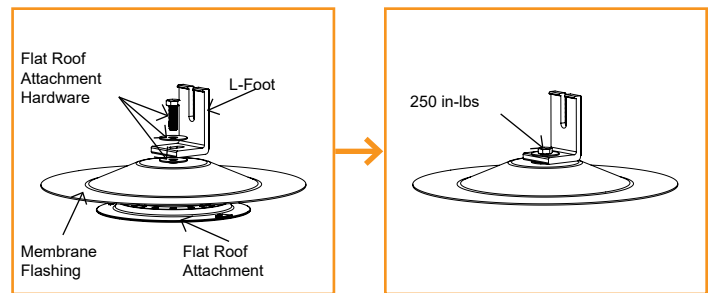

### QM QBASE MOUNT

Locate the desired mount placement over a rafter. Using the base as a template, mark the two penetration points. Drill two 7/32" pilot holes, back fill with roofing manufacturers' approved sealant. Place the grade-8 hex bolt in the bottom of the base and screw the Post. Attach L-Foot on Standoff with hardware. Torque to **174 in-lbs (14.5 ft-lbs)**. Attach rail to L-Foot with Bonding Hardware and torque to **250 in-lbs (21 ft-lbs)**.

The mount can be flashed with available 9", 12" or 18" aluminum flashings, pitch pocket or curb, or with a membrane cone flashing. If using a membrane flashing utilize the services of a qualified roofer

- For additional details refer to the full QM [Installation Manual](#).

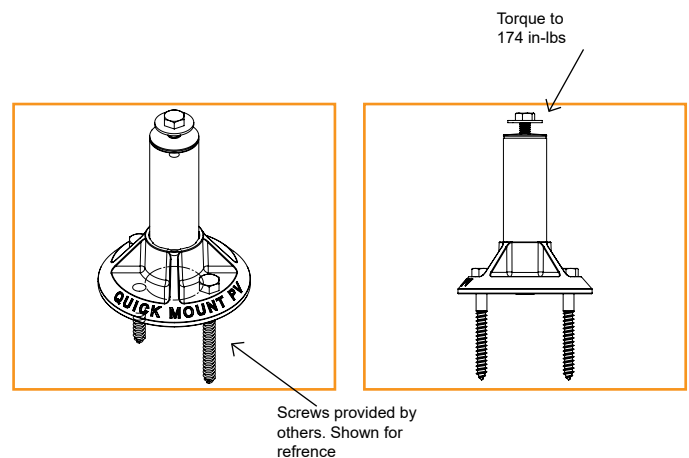

## METAL ROOF

### QM LYNX

Locate the desired mount placement over a roofing seam, make sure block is fully seated on metal seam. Torque Set Screws to **150 in-lbs(12.5 ft-lbs)** using 3/16" Hex Drive, alternate driving each bolt till required torque is met. Slide Hex Bolt into slot and to desired position. Place rail attachment bracket over Hex Bolt and secure with Flange Nut, torque Flange Nut to **150 in-lbs(12.5 ft-lbs)** using 1/2" socket.

- For additional details refer to the full QM [Installation Manual](#).
- Certification of Lynx calmp includes bonding to both painted and galvalume metal roofs.

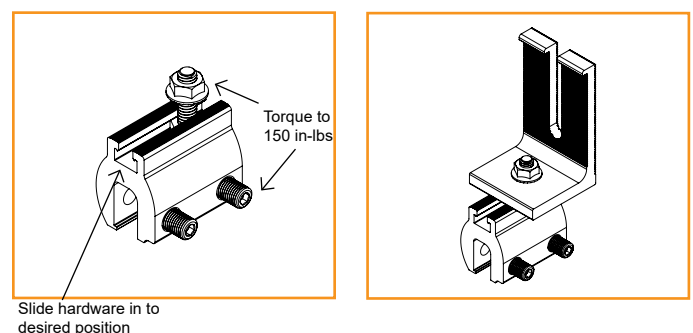



## CONDUIT PENETRATION FLASHINGS

### QM CONDUIT PENETRATION FLASHING - COMP SHINGLE

Mark a drill point so that the flashing reaches up to the 3rd shingle course. Drill your conduit hole next to the rafter so you can secure the conduit below the roof surface. Cut shingle and remove nails as needed to center the drilled hole and flashing hole. Apply roofing manufacturer's approved sealant on the underside of the flashing in a Upside down U and to top of flashing. Under the 3rd course and through the second course secure flashing with 2 roofing nails, apply sealant over the nail heads. Cut EPDM collar to appropriate size. Apply a bead of sealant compatible with the roofing manufacturer and EPDM rubber to anywhere the EPDM collar contacts.

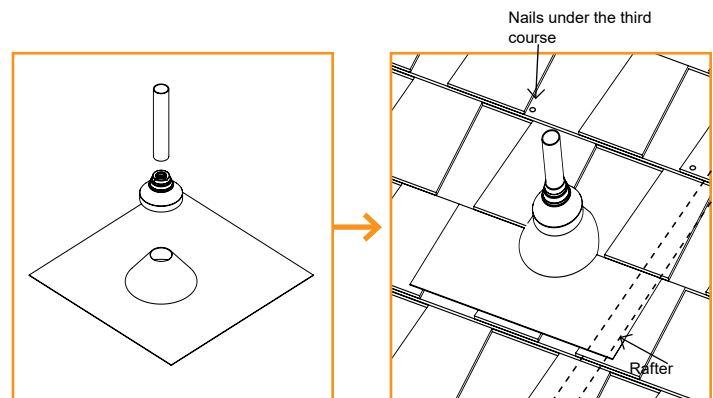

- Be sure to secure conduit to rafters below the roof surface per local building codes and NEC code requirements.
- Cut EPDM collar to appropriate size using the sizing chart in the installation manual, approved for 1/2" to 1" EMT.
- For additional details refer to the full QM [Installation Manual](#).

### QM CONDUIT PENETRATION FLASHING - TILE

Drill your conduit hole next to the rafter so that you can secure the conduit below the roof surface. Apply roofing manufacturer approved sealant to the underside of the sub-flashing in the shape of an upside down U. Clear away any dust and debris to install sub-flashing. Waterproof at under laminate level according to roofing manufacturer instructions and Tile Roofing Institute Guidelines. Under the top layer of felt, secure the sub-flashing with two roofing nails. Cut EPDM collar to appropriate size. Apply a bead of sealant compatible with the roofing manufacturer and EPDM rubber to anywhere the EPDM collar contacts. With a diamond blade cut tile to allow conduit to pass through, replace all tiles. Bend the flashing to follow the contour of the tiles. Place flashing over the conduit and tuck up under the next course of tiles. Apply a bead of sealant compatible with the roofing manufacturer and EPDM rubber to anywhere the EPDM collar contacts. Slide collar onto conduit all the way down to the flashing.

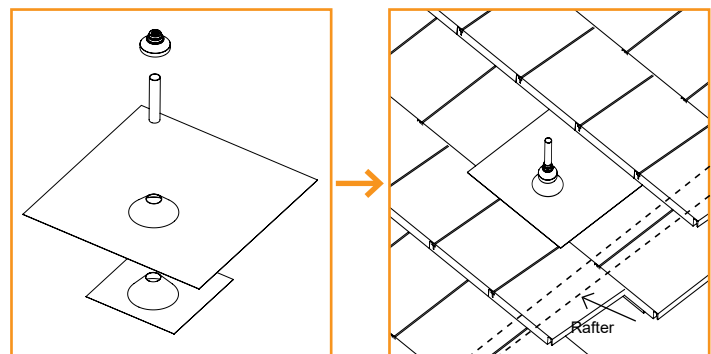

- Be sure to secure conduit to rafters below the roof surface per local building codes and NEC code requirements.
- Cut EPDM collar to appropriate size using the sizing chart in the installation manual, approved for 1/2" to 1" EMT.
- For additional details refer to the full QM [Installation Manual](#).

## CONDUIT MOUNT

### QM CONDUIT MOUNT - COMPOSITION SHINGLE

Place conduit mounts along path of conduit. Lift shingle above mount location and insert flashing into position. Mark center for drilling, remove flashing and drill pilot hole with 1/8" bit. Clean area, fill hole with roofing manufacturer's approved sealant. Lift shingle and slide Conduit Mount into place. Prepare the lag bolt with sealing washer and pipe clamp (not included). Insert lag through hole in block and drill with 7/16" socket until block is tight.

- Install mounts as required to support conduit across the roof.
- For additional details refer to the full QM [Installation Manual](#).

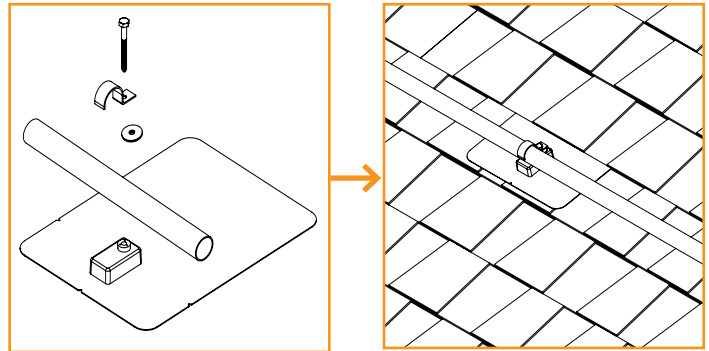

### QM CONDUIT MOUNT - TILE

Remove the tile that the mount will be installed on, and the tiles in the course above it. Lift the bottom of the tile and slide the bottom clamp over the bottom edge of the tile. Insert the 4" tap bolt through the slot into the threaded hole and use a 7/16" socket to thread the screw. Tighten until the top clamp hook end unbends and forms a 90 degree angle with the tile. Use the Cap Screw (included) to attach your pipe clamp (not included) to bottom clamp. Insert conduit and tighten with 7/16" socket.

- The clamp is reversible, use the wider hook end on tile greater than 1" thick and the thinner hook end on tiles less than 1" thick.
- The installation process is the same on curved tile, make sure that the Conduit Mount is installed on the crown (high point) of the tile.
- Install mounts as required to support conduit across the roof.
- For additional details refer to the full QM [Installation Manual](#).

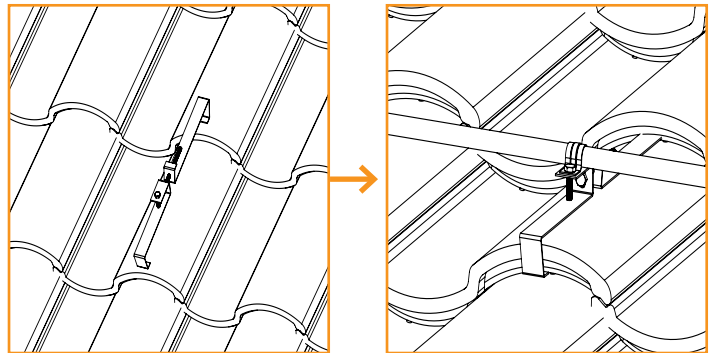

## WIRE CLIPS

End Caps add a completed look and keep debris and pests from collecting inside rail.

Firmly press End Cap onto rail end.

- End Caps come in sets of left and right. Check that the proper amount of each has been provided.

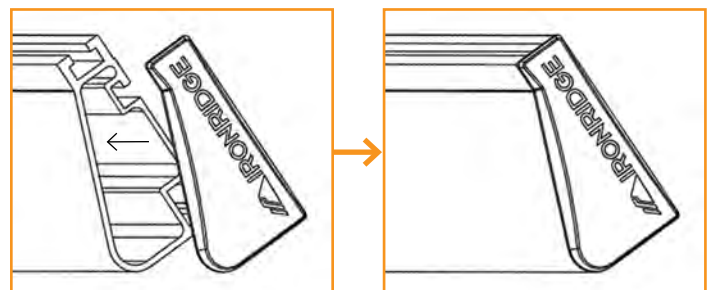

## WIRE CLIPS

Wire Clips offer a simple wire management solution.

Firmly press Wire Clip into top rail slot. Run electrical wire through open clip. Snap closed once all wires have been placed.

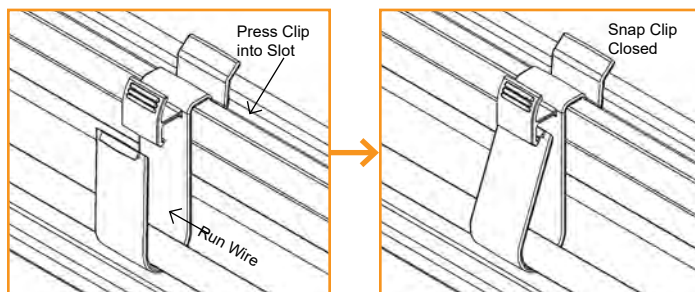

## JAYBOX

### A.

Prior to installation, use step drill bit to place pass through holes for conduits or water-tight connectors. Drill bit starter locations are provided on the sides and front of enclosure.

- Do not install conduit facing up roof.

### B (Rail).

Use rail-specific MLPE mounting hardware to attach Rail Hangers to rail. Ensure junction box is pushed as close to the rail as possible. Torque to 80-in lbs (1/2" or 7/16" socket).

- Do not overtighten
- If installing in areas with ground snow loads greater than 40 psf, install JayBox under module directly next to module frame edge.

### B (Shingle).

Align sealing oval of box to align with mating feature on flashing. An EPDM foam gasket is pre-installed to the underside of the junction box to seal the flashing to the box without the need for additional sealant. Secure with supplied #12 x 1-3/4" deck screws (2x) until the junction box is pulled tight to the flashing. Do not over-tighten screws to avoid stripping screws in OSB.

- If installing pass through fittings, ensure that the JayBox and roof deck are both properly prepared. Complete installation process before attaching the Jaybox to the deck.
- Do not install JayBox under shingle seam as illustrated below.

### C.

Install wiring, conduit and fittings per NEC requirements and following local AHJ guidance. Using Philips Head Driver tighten the bolt.

- For additional details refer to the full QM [Installation Manual](#).

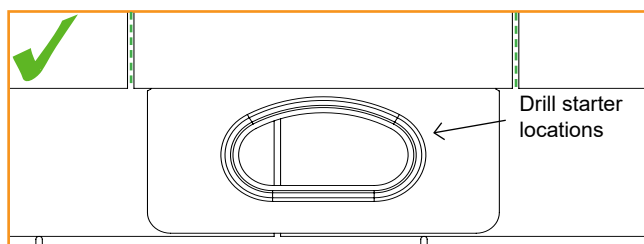
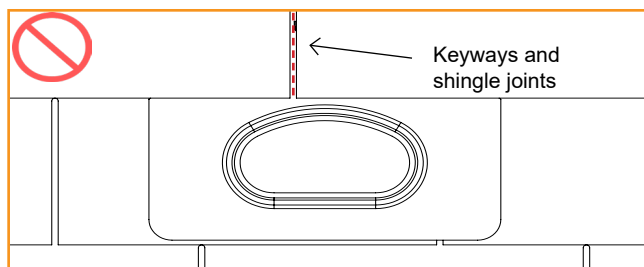
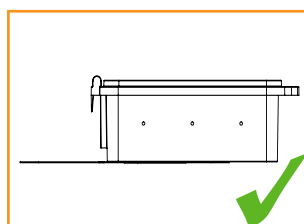
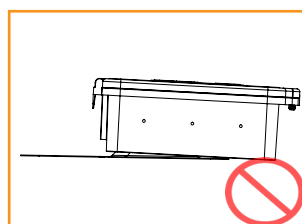
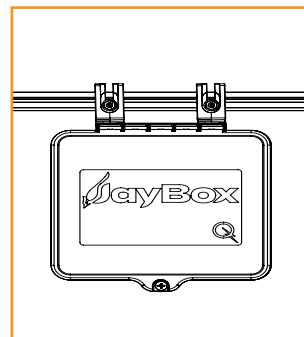
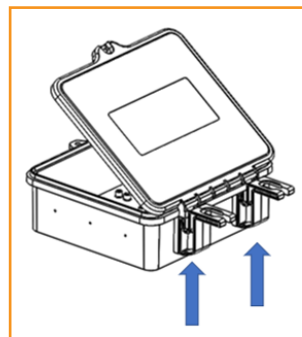
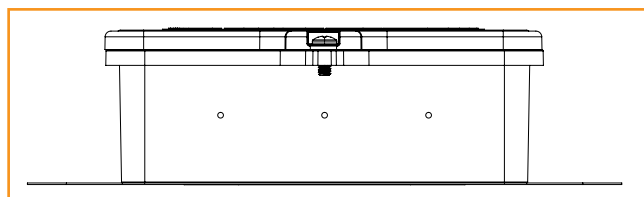

## MICROINVERTER KITS

Use IronRidge's Microinverter Kit to bond compatible microinverters and power optimizers to the racking system.

Insert Microinverter Kit T-bolt into top rail slot. Place compatible microinverter or power optimizer into position and tighten hex nut to **80 in-lbs**.

- If installing in areas with ground snow loads greater than 40 psf, install MLPE devices directly next to module frame edge

### COMPATIBLE PRODUCTS

#### Enphase

M250-72, 250-60, M215-60, C250-72, S230, S280, IQ 6, IQ 6+, IQ IQ7, IQ 7A, IQ 7+, IQ7 PD, IQ 7X, Q Aggregator; IQ8-60, IQ8PLUS-72, IQ8A-72, IQ8H-208-72, IQ8H-240-72, IQ8M-72, may be followed by -2-US

#### Darfon

MIG240, MIG300, G320, G640

#### Solar Edge

M1600, P300, P320, P340, P370, P400, P401, P405, P485, P505, P600, P700, P730, P800p, P800s, P801, P850, P860, P950, P960, P1100, P1101, S440, S500

#### SMA

RoofCommKit-P2-US, TS4-R Module Retrofit Kits (TS4-R-S, TS4-R-O, TS4-R-F)

#### Tigo

Tigo Access Point (TAP)

TS4-R-X (where X can be F, M, O, or S)

TS4-R-X-DUO (where X can be M, O, or S)

TS4-A-X (where X can be F, 2F, O, O-DUO, or S)

#### Generac

S2502

#### AP Systems

QS1, YC600

- Remove Grounding Washer on AP Systems QS1 and YC600 inverters before installing to XR rails.
- Remove the Stainless Steel Clip on Tigo-"A" MLPE Devices before attaching to XR rails.
- Use the number of IronRidge Microinverter kits allowed by the MLPE mounting flange. Some will require 1 kit and others 2 kits.

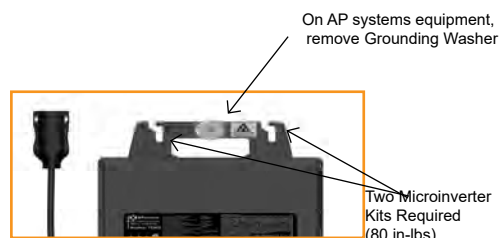
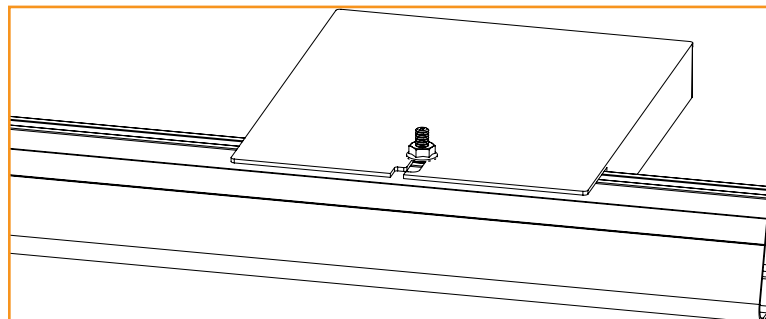
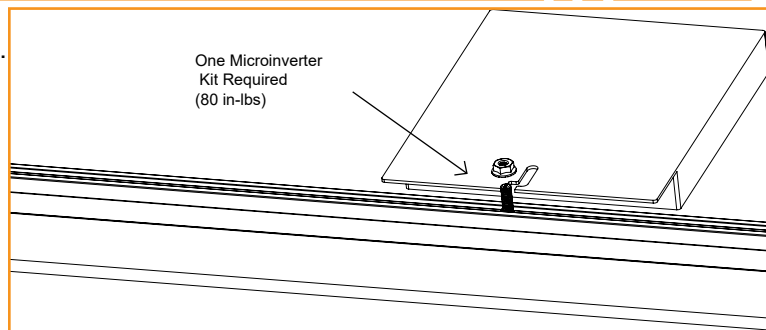

## SYSTEMS USING ENPHASE MICROINVERTERS OR SUNPOWER AC MOD-

IronRidge systems using approved Enphase products or SunPower modules eliminate the need for lay-in lugs and field installed equipment grounding conductors (EGC). This solution meets the requirements of UL 2703 for bonding and grounding and is included in this listing.

### COMPATIBLE PRODUCTS

#### Sunpower

Modules with model identifier Ab-xxx-YY and InvisiMount (G5) 46mm frame; where "A" is either E, or X; "b" can be 17, 18, 19, 20, 21, or 22; and "YY" can be C-AC, D-AC, BLK-C-AC, or BLK-D-AC.

#### Enphase

Microinverters M250-72, M250-60, M215-60, C250-72, and Engage cables ETXX-240, ETXX-208, ETXX-277.

- A minimum of two inverters mounted to the same rail and connected to the same Engage cable are required.
- The microinverters or Sunpower AC modules must be used with a maximum 20 A branch rated overcurrent protection device (OCPD).
- If an AC module is removed from a circuit for maintenance, you must first disconnect AC power and then install a temporary EGC to bridge the gap by inserting an AC extension cable (or via other NEC-compliant means), in order to maintain effective ground continuity to subsequent modules.

## SYSTEMS USING MICROSTORAGE PRODUCTS

Use IronRidge's Microinverter Kit to bond compatible microstorage devices to the racking system. Insert Microinverter Kit T-bolt into top rail slot. Place compatible microstorage into position and tighten hex nut to **80 in-lbs**.

### COMPATIBLE PRODUCTS

#### PHAZR

PHAZR Devices PHAZR-X, where X is 6-12.

#### Solpad

Solpad Inverter model SI-1k

Solpad Battery Storage model SB-2K

Solpad Junction Box model SJB-4k

- Running a separate equipment grounding conductor to the PHAZR or Solpad devices is not required.
- If installing in areas with ground snow loads greater than 40 psf and underneath a module, install PHAZR and Solpad devices as close as possible to module frame edge.
- Solpad may only be installed on XR-100 and XR-1000
- Solpad may only be installed with modules having a frame thickness of 35mm or greater.
- Use the number of IronRidge Microinverter kits allowed by the microstorage mounting flange. Some will require 1 kit and others 2 kits.

PHAZR

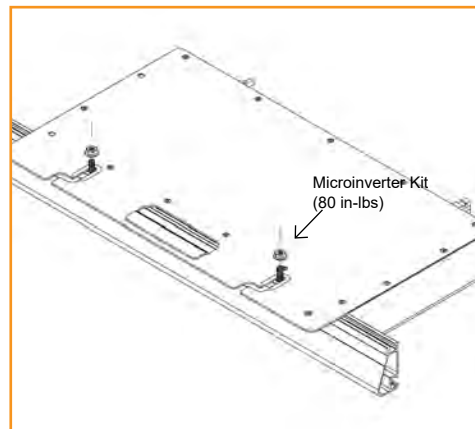

Solpad

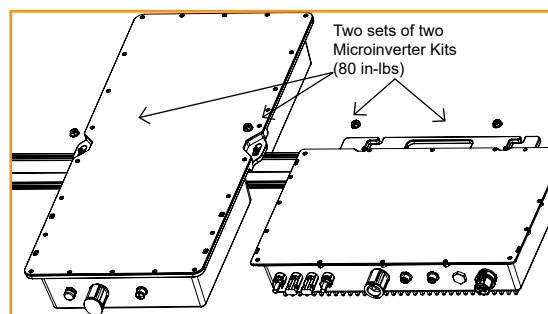

## FRAMELESS MODULE KITS

Insert Frameless Kit T-bolt in top rail slot. Place star washer over T-bolt, allowing it to rest on top of rail. Secure module clamps with a hex nut and torque to **80 in-lbs**.

### COMPATIBLE PRODUCTS

#### Sunforson

Sunforson silver or black SFS-UTMC-200(B) mid and SFS-UTEC-200(B) end clamps.

#### Sunpreme

Sunpreme silver or black mid and end clamps with part numbers 7500105X where "X" is 1, 5, 6 or 7.

#### Ironridge

IronRidge silver or black mid and end clamps with part numbers FMLS-XC-001-Y where "X" is E or M and "Y" is B or blank.

- Follow module manufacturer's installation instructions to install the module clamps.
- Frameless modules require using a Grounding Lug on every rail.
- For Sunpreme Modules Only: If required to use slide prevention hardware, see Module Slide Prevention Addendum (Version 1.10).

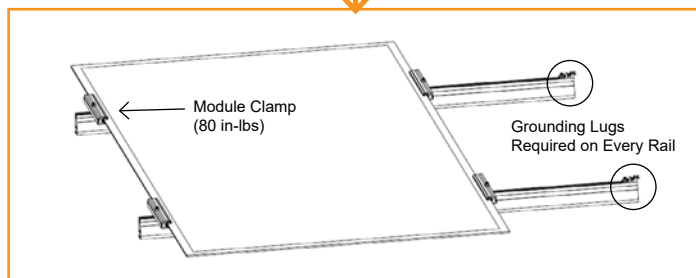
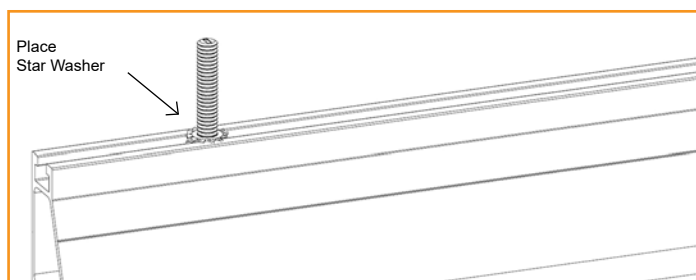

## Install Contour

Install Contour on a completed array.

**A.** Start by placing Contour Clamp on module frame within 12 inches of the down roof corner of the array. Each piece of 84" Contour Trim must be supported by two Clamps. Clamps must be installed in the 12" clamping zones at edge of trim. Once trim is placed and in position, secure trim by tightening Clamp set screw to **80 in-lbs**.

**B.** Multiple Contour pieces can be joined using Contour Splice. Install Splice on existing Contour edge and install Clamps in appropriate clamping zones for next piece of trim. Place trim on Clamps, slide into splice to join two pieces together. Secure Contour by tightening Clamp set screw to **80 in-lbs**. Repeat as needed across the array.

**C.** Cut trim to line up with edge of array.

**D.** Install Clamps within clamping zones on side of array. Install second Clamp as needed up array. Place Corner Cap on trim and slide side trim to align with Cap. Repeat as needed along roof for both inside and outside corners.

**E.** Use optional End Caps to cover any exposed edges of Contour as desired.

- Do not install on side of array facing roof peak.
- Contour can be installed with 1 clamp if trim section is 12" long (or shorter) and has a splice attached on one end, on which the section of trim the 12" section is spliced to also has 2 clamps.
- Contour Trim when installed when installed up roof requires the use of Aire Stealth Clamps.
- Wind Speed: no restrictions
- Ground Snow: up to 90 PSF

**A.**

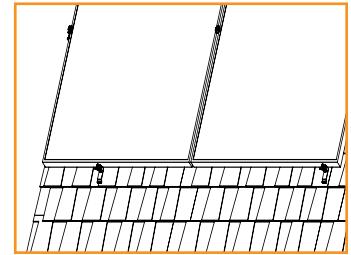
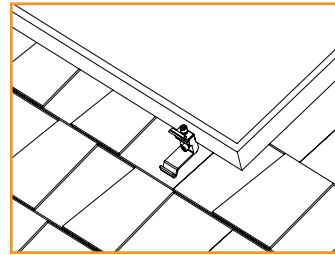
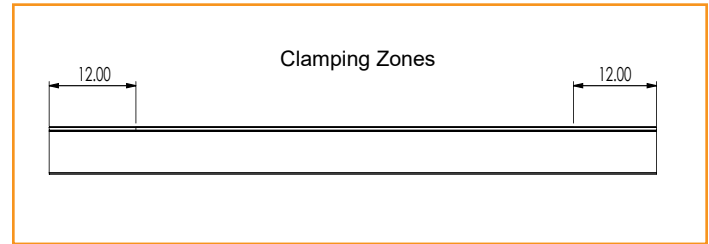

**B.**

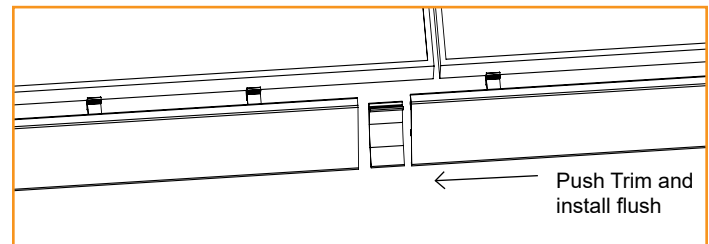

**C.**

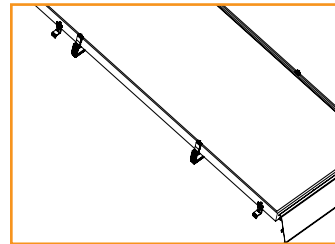

**D.**

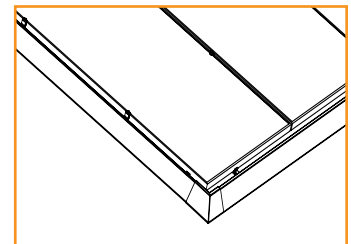

**E.**

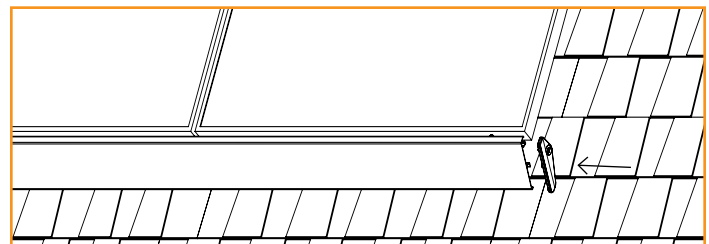

## MODULE COMPATIBILITY

The Flush Mount System may be used to ground and/or mount a PV module complying with UL 2703 only when the specific module has been evaluated for grounding and/or mounting in compliance with the included instructions. Unless otherwise noted, "xxx" refers to the module power rating and both black and silver frames are included in the certification.

### FRAMED MODULE LIST

MAKE	MODELS
Adani	Adani modules with 35 and 40mm frames ASX-Y-ZZ-xxx Where "X" can be B, M or P; "Y" can be 6, 7 or M10 and "ZZ" can be blank, 144, PERC, B-PERC, or AB-PERC
AIONRISE	AIONRISE modules with 35 and 40mm frames AIONyyG1-xxx Where "yy" can be 60 or 72
Amerisolar	Amerisolar modules with 35 and 40 mm frames AS-bYxxxZ Where "b" can be 5 or 6; "Y" can be M, P, M27, P27, M30, or P30; and "Z" can be blank, W or WB
Aptos Solar	Aptos modules with 35 and 40 mm frames DNA-yy-zzaa-xxx Where "yy" can be 120 or 144; "zz" can be MF or BF; and "aa" can be 23 or 26
Astronergy Solar	Astronergy modules with 30, 35 and 40 mm frames aaSMbbyyC/zz-xxx Where "aa" can be CH or A; "bb" can be 60, 66, or 72; "yy" can be blank, 10 or 12; "C" can M, P, M(BL), M-HC, M(BL)-HC, P-HC, M(DG), or M(DGT); and "zz" can be blank, HV, F-B, or F-BH
ASUN	ASUN modules with 35 and 40 mm frames ASUN-xxx-YYZZ-aa Where "YY" can be 60 or 72; "ZZ" can be M, or MH5; and "aa" can be blank or BB
Auxin	Auxin modules with 40 mm frames AXN6y6zAxxxB Where "y" can be M or P; "z" can be 08, 09, 10, 11, or 12; and "A" can be F, M or T; and "B" can be blank, A, B or C
Axitec	Axitec Modules with 30, 35 and 40 mm frames AC-xxxY/aaZZb Where "Y" can be M, P, MB or MH; "aa" can be blank, 125- or 156-; "ZZ" can be 54, 60, 72, 108, 120, or 144; "b" can be S, X, V, VB, XV, or MX
Boviet	Boviet modules with 35 and 40mm frames BVMZZaaYY-xxxBcc Where "ZZ" can be 66 or 76; "aa" can be 9, 10 or 12; "YY" is M or P; and "B" can be blank, L or S; and "cc" can be blank, H, H-BF, H-BF-DG, H-HC, H-HC-BF, H-HC-BF-DG, HC-BF or HC-BF-DG
BYD	BYD modules with 35 mm frames BYDxxxAY-ZZ Where "A" can be M6, P6, MH or PH; "Y" can be C or K; and "ZZ" can be 30 or 36
Canadian Solar	Canadian Solar modules with 30, 32, 35 and 40 mm frames CSbY-xxxZ Where "b" can be 1, 3, 6 or 7 "Y" can be H, K, L, N, P, U, V, W, X or Y; and "Z" can be M, P, MS, PX, M-SD, P-AG, P-SD, MB-AG, PB-AG, MS-AG, or MS-SD
CertainTeed	CertainTeed modules with 35 and 40 frames CTxxxYZZ-AA Where "Y" can be M, P, or HC; "ZZ" can be 00, 01, 10, or 11; and "AA" can be 01, 02, 03, 04 or 06
CSUN	Csun modules with 35 and 40 mm frames YYxxx-zzAbb Where "YY" is CSUN or SST; "zz" is blank, 60, or 72; and "A" is blank, P, M or MM; "bb" is blank, BB, 5BB, BW, or ROOF
Dehui	Dehui modules with 30, 35 and 40mm frames DH-MYYYZ-xxx Where "YYY" can be 760, 772, 860, 872; and "Z" can be B, F or W

## MODULE COMPATIBILITY

Ecosolargy	Ecosolargy modules with 35 and 40 mm frames ECOxxxYzzA-bbD Where "Y" can be A, H, S, or T; "zz" can be 125 or 156; "A" can be M or P; "bb" can be 60 or 72; and "D" can be blank or B
ET Solar	ET Solar modules with 30, 35 and 40 mm frames ET-YZZZxxxAA Where "Y" can be P, L, or M; "ZZZ" can be 660, 660BH, 672, 672BH, 754BH, 766BH, 772BH; and "AA" can be GL, TB, TW, WB, WW, BB, WBG, WWG, WBAC, WBCO, WWCO, WWBCO or BBAC
Flex	Flex modules with 35 and 40 mm frames FXS-xxxYY-ZZ; Where "YY" can be BB or BC; and "ZZ" can be MAA1B, MAA1W, MAB1W, SAA1B, SAA1W, SAC1B, SAC1W, SAD1W, SBA1B, SBA1W, SBC1B, or SBC1W
Freedom Forever	Freedom Forever modules with 35mm frames FF-MP-BBB-xxx
GCL	GCL modules with 35 mm and 40 mm frames GCL-ab/YY xxx Where "a" can be M or P; "b" can be 3 or 6; and "YY" can be 60, 72, 72H, or 72DH
GigaWatt Solar	Gigawatt modules with 40 mm frames GWxxxYY Where "YY" can be either PB or MB
Hansol	Hansol modules with 35 and 40 frames HSxxxYY-zz Where "YY" can be PB, PD, PE, TB, TD, UB, UD, or UE; and "zz" can be AH2, AN1, AN3, AN4, HH2, HV1, or JH2
Hanwa Solar	Hanwa Solar modules with 40 mm frames HSLaaP6-YY-1-xxxZ Where "aa" can be either 60 or 72; "YY" can be PA or PB; and "Z" can be blank or B
Hanwa Q CELLS	Hanwa Q CELLS Modules with 32, 35, 40mm frames aaYY-ZZ-xxx where "aa" can be Q. or B.; "YY" can be PLUS, PRO, PEAK, LINE PRO, LINE PLUS, PLUS DUO or PEAK DUO; and "ZZ" can be G3, G3.1, G4, G4.1, L-G2, L-G2.3, L-G3, L-G3.1, L-G3y, L-G4, L-G4.2, L-G4y, LG4.2/TAA, BFR-G3, BLK-G3, BFR-G3.1, BLK-G3.1, BFR-G4, BFR-G4.1, BFR G4.3, BLK-G4.1, G4/SC, G4.1/SC, G4.1/TAA, G4.1/MAX, BFR G4.1/TAA, BFR G4.1/MAX, BLK G4.1/TAA, BLK G4.1/SC, EC-G4.4, G5, G5/SC, G5/TS, BLK-G5, BLK-G5/SC, BLK-G5/TS, L-G5, L-G5.1, L-G5.2, L-G5.2/H, L-G5.3, G6, G6/SC, G6/TS, G6+/TS, G6+, BLK-G6, L-G6, L-G6.1, L-G6.2, L-G6.3, G7, BLK-G6+, BLK-G6+/AC, BLK-G6+/HL, BLK-G6+/SC, BLK-G6/TS, BLK-G6+/TS, BLK-G7, G7.2, G8, BLK-G8, G8+, BLK-G8+ L-G7, L-G7.1, L-G7.2, L-G7.3, L-G8, L-G8.1, L-G8.2, L-G8.3, L-G8.3/BFF, L-G8.3/BFG, L-G8.3/BGT, ML-G9, BLK ML-G9, ML-G9+, BLK ML-G9+, BLK-G10+, BLK G10+/AC, ML-G10, BLK ML-G10, ML-G10+, BLK ML-G10+, ML-G10.a, BLK ML-G10.a, ML-G10.a+, BLK ML-G10.a+, XL-G9, XL-G9.2, XL-G9.3, XL-G9.3/BFG, XL-G10.2, XL-G10.3, XL-G10.c, XL-G10.d, XL-G10.d/BFG, XL-G10.3/BFG or XL-G11.3/BFG
Heliene	Heliene modules with 40 mm frames YYZZxxxA Where "YY" can be 36, 60, 72, 96, 120 or 144; "ZZ" can be HC, M, P, or MBLK; and "A" can be blank, HomePV, Bifacial or M10 Bifacial
HT-SAAE	HT-SAAE modules with 35 and 40 mm frames HTyy-aaaZ-xxx Where "yy" can be 60, 66, 72 or 78, "aaa" can be 18, 156 or 166, "Z" can be M, P, M-C, P-C, M(S), M(VS), M(V), P(V), M(V)-C, P(V)-C, or X
Hyundai	Hyundai modules with 33, 35 and 40 mm frames HiY-SxxxZZ Where "Y" can be A, D or S; "S" can be M or S; and "ZZ" can be GI, HG, HI, KI, MI, MF, MG, PI, RI, RG, RG(BF), RG(BK), SG, TI or TG
Itek	Itek Modules with 40 mm frames IT-xxx-YY Where "YY" can be blank, HE, or SE, or SE72



## MODULE COMPATIBILITY

JA Solar	<p>JA Solar modules with 30, 35 and 40 mm frames                      JAyyzz-bbww-xxx/aa                      Where "yy" can be M, P, M6 or P6; "zz" can be blank, (K), (L), (R), (V), (BK), (FA), (TG), (FA)(R), (L)(BK), (L)(TG), (R)(BK), (R)(TG), (V)(BK), (BK)(TG), or (L)(BK)(TG); "bb" can be 48, 54, 60, 66, 72 or 78; "ww" can be D09, D10, D20, D30, S01, S02, S03, S06, S09, S10, S12, S17, S20, S30 or S31; and "aa" can be BP, MB, MR, SI, SC, PR, 3BB, 4BB, 4BB/RE, 5BB</p>
Jinko	<p>Jinko modules with 35 and 40 mm frames                      JKMYxxxZZ-aa                      Where "Y" can either be blank or S; "ZZ" can be M, P, or PP; and "aa" can be blank, 60, 60B, 60H, 60L, 60BL, 60HL, 60HB, 60HBL, 6HBL-EP, 60-J4, 60B-J4, 60B-EP, 60(Plus), 60-V, 60-MX, 6RL3, 6RL3-B, 6TL3-B, 7RL3-V, 7RL3-TV, 72, 72B, 72-J4, 72B-J4, 72(Plus), 72-V, 72H-V, 72L-V, 72HL-V, 72HL4-V, 72HL4-TV, 72-MX, 72H-BDVP, 72HL-TV, or 72HL-V-MX3</p>
Kyocera	<p>Kyocera Modules                      KYxxxZZ-AA                      Where "Y" can be D or U; "ZZ" can be blank, GX, or SX; and "AA" can be LPU, LFU, UPU, LPS, LPB, LFB, LFBS, LFB2, LPB2, 3AC, 3BC, 3FC, 4AC, 4BC, 4FC, 4UC, 5AC, 5BC, 5FC, 5UC, 6BC, 6FC, 8BC, 6MCA, or 6MPA</p>
LG	<p>LG modules with 35 and 40 mm frames                      LGxxxYaZ-bb                      Where "Y" can be A, E, M, N, Q, S; "a" can be A, 1, 2 or 3 "Z" can be C, K, T, or W; and "bb" can be A3, A5, A6, B3, B6, E6, E6.AW5, G3, G4, J5, K4, L5, N5, V5, V6</p>
Longi	<p>Longi modules with 30, 35 and 40 mm frames                      LRa-YYZZ-xxxM                      Where "a" can be 4, 5 or 6; "YY" can be blank, 60, 66, or 72; and "ZZ" can be blank, BK, BP, HV, PB, PE, PH, HBD, HIB, HIH, HPB, HPH, or HIBD</p>
Maxeon	<p>Maxeon modules with 35, 40 and 46mm frames                      SPR-AAAY-xxx-zzz                      Where "AAA" can be MAX, P or X; "Y" can be 3, 5, 6, 21 or 22; and "zzz" can be BLK, COM or UPP</p>
Meyer Burger	<p>Meyer Burger Modules with 35mm frames                      Meyer Burger Black</p>
Mission Solar	<p>Mission Solar modules with 33, 35 and 40 mm frames                      YYYbb-xxxZZaa                      Where "YYY" can be MSE or TXS; "bb" can be blank, 6 or 60A; "ZZ" can be blank, MM, SE, SO, SQ, SR, SX, TS, 120 or 144; and "aa" can be blank, BB, BW, 1J, 4J, 4S, 5K, 5R, 5T, 60, 6J, 6S, 6W, 6Z, 8K, 8T, or 9S</p>
Mitsubishi	<p>Mitsubishi modules                      PV-MYYxxxZZ                      Where "YY" can be LE or JE; and "ZZ" can be either HD, HD2, or FB</p>
Moltech	<p>IM and XS series modules with 40 mm frames</p>
Next Energy Alliance	<p>Next Energy Alliance modules with 35 and 40mm frames                      yyNEA-xxxZZ                      where "yy" can be blank or US; "ZZ" can be M, MB or M-60</p>
Neo Solar Power	<p>Neo Solar Power modules with 35 mm frames                      D6YxxxZZaa                      Where "Y" can be M or P; "ZZ" can be B3A, B4A, E3A, E4A, H3A, H4A; and "aa" can be blank, (TF), ME or ME (TF)</p>
Panasonic (HIT)	<p>Panasonic modules with 35 and 40 mm frames                      VBHNxxxYYzZA                      Where "YY" can be either KA, RA, SA or ZA; "zz" can be either 01, 02, 03, 04, 06, 06B, 11, 11B, 15, 15B, 16, 16B, 17, or 18; and "A" can be blank, E, G, or N</p>
Panasonic (EverVolt)	<p>Panasonic modules with 30 mm frames                      EVPVxxxA                      Where "A" can be blank or H, K or PK</p>
Peimar	<p>Peimar modules with 40 mm frames                      SbxxxYzz                      Where "b" can be G, M or P; "Y" can be M or P; and "zz" can be blank, (BF) or (FB)</p>

# MODULE COMPATIBILITY

Philadelphia Solar	Philadelphia modules with 35 and 40 mm frames PS-YzzAA-xxx Where "Y" can be M or P; "zz" can be 60, 72 or 144; and "AA" can be blank, (BF), (HC) or (HCBF)
Phono Solar	Phono Solar modules with 35 and 40 mm frames PSxxxY-ZZ/A Where "Y" can be M, M1, MH, M1H, M4, M4H or P; "ZZ" can be 20 or 24; and "A" can be F, T, U, UH, or TH
Prism Solar	Prism Solar modules with 35mm frames PST-xxxW-M72Y Where "Y" can be H, HB or HBI
Recom	Recom modules with 35 and 40 mm frames RCM-xxx-6yy Where "yy" can be MA, MB, ME or MF
REC Solar	REC modules with 30 and 38 mm frames RECxxxYYZZ Where "YY" can be AA, M, NP, NP2, PE, PE72, TP, TP2, TP2M, TP2SM, TP2S, TP3M or TP4; and "ZZ" can be blank, Black, BLK, BLK2, SLV, 72, or Pure
Renesola	ReneSola modules with 35 and 40 mm frames AAxxxY-ZZ Where "AA" can be SPM(SLP) or JC; "Y" can be blank, F, M or S; and "ZZ" can be blank, Ab, Ab-b, Abh, Abh-b, Abv, Abv-b, Bb, Bb-b, Bbh, Bbh-b, Bbv, Bbv-b, Db, Db-b, or 24/Bb
Renogy	Renogy Modules with 40 mm frames RNG-xxxY Where "xxx" is the module power rating; and "Y" can be D or P
Risen	Risen Modules with 30, 35 and 40 mm frames RSMyy-a-xxxZZ Where "yy" can be 60, 72, 110, 120, 132 or 144; "a" can be 6, 7 or 8; and "ZZ" can be M, P or BMDG
S-Energy	S-Energy modules with 35 and 40mm frames SABB-CCYYY-xxxZ Where "A" can be C, D, L or N; "BB" can be blank, 20, 25, 40 or 45; "CC" can be blank, 60 or 72; "YYY" can be blank, BDE, MAE, MAI, MBE, MBI, MCE or MCI; and "Z" can be V, M-10, P-10 or P-15
SEG Solar	SEG Solar with 30, 35 and 40 mm frames SEG-aYY-xxxZZ Where "a" can be blank, 6 or B; "YY" can be blank, MA, MB, PA, or PB; and "ZZ" can be blank, BB, BG, BW, HV, WB, WW, BMB, BMA-HV, BMA-BG, BMA-TB, BMB-TB, BMB-HV, BMD-HV, BMB-BG
Seraphim USA	Seraphim modules with 30, 35 and 40 mm frames SRP-xxx-YYY-ZZ Where "xxx" is the module power rating; and "YYY" can be BMA, BMD, 6MA, 6MB, 6PA, 6PB, 6QA-XX-XX, and 6QB-XX-XX; ZZ is blank, BB, BG or HV
Sharp	Sharp modules with 35 and 40 mm frames NUYYxxx Where "YY" can be SA or SC
Shinsung E&G	Shinsung Modules with 35mm frames SSVxxx-144MH
Silfab	Silfab Modules with 35 and 38 mm frames SYY-Z-xxxAb Where "YY" can be IL, SA, LA, SG or LG; "Z" can be blank, M, P, or X; "A" can be blank, B, H, M, N; and "b" can be A, C, G, K, L, N, T, U or X
Solaria	Solaria modules with 35 and 40 mm frames PowerXT-xxxY-ZZ Where "Y" can be R or C; and "ZZ" can be AC, BD, BX, BY, PD, PL, PM, PM-AC, PX, PZ, WX or WZ
Solarcity (Tesla)	Solarcity modules with 40 mm frames SCxxxYY Where "YY" can be blank, B1 or B2
SolarTech	SolarTech modules with 40 mm frames AAA-xxxYY Where "AAA" can be PERCB-B, PERCB-W, HJTb-B, HJTb-W or STU; "YY" can be blank, PERC or HJT

# MODULE COMPATIBILITY

SolarWorld AG	SolarWorld Sunmodule Plus, Protect, Bisun, XL, Bisun XL, may be followed by mono, poly, duo, black, bk, or clear; modules with 31 and 33 mm frames SW-xxx
SolarWorld Americas	SolarWorld Sunmodule Plus, Protect, Bisun, XL, Bisun XL, may be followed by mono, poly, duo, black, bk, or clear; modules with 33 mm frames SWA-xxx
Sonali	Sonali Modules with 35 and 40 mm frames SS-M-xxx Where "M" can be blank or M
Stion	Stion Thin film modules with 35 mm frames STO-xxx or STO-xxxA
SunEdison	SunEdison Modules with 35 and 40 mm frames SE-YxxxZABCDE Where "Y" can be B, F, H, P, R, or Z; "Z" can be 0 or 4; "A" can be B,C,D,E,H,I,J,K,L,M, or N; "B" can be B or W; "C" can be A or C; "D" can be 3, 7, 8, or 9; and "E" can be 0, 1 or 2
Suniva	Suniva modules with 35, 38 and 40 mm frames OPTxxx-AA-B-YYY-Z MVXxxx-AA-B-YYY-Z Where "AA" is either 60 or 72; "B" is either 4 or 5; "YYY" is either 100,101,700,1B0, or 1B1; and "Z" is blank or B
Sunpower	Sunpower standard (G3 or G4) or InvisiMount (G5) 35 and 40mm frames SPR-Zb-xxx-YY Where "Z" can be A, E, M, P or X; "b" can be blank, 17, 18, 19, 20, 21, or 22; and "YY" can be blank, BLK, COM, C-AC, D-AC, E-AC, BLK-E-AC, G-AC, H-AC, BLK-C-AC, or BLK-D-AC
Sunspark	Sunspark modules with 40 mm frames SYY-xxxZ-A Where "YY" can be MX or ST; and "Z" can be M, MB, M3, M3B, P or W; and "A" can be 60 or 72
Suntech	Suntech Modules with 35 and 40mm frames STPxxxz-aa Where "y" is blank or S; and "zz" can be 20, 24, A60, A72U, B60 or B72; and "aa" can be Vd, Vem, Vfw, Vfh, Vnh, Wdb, Wde, Wd, Wfhh or Wnhb
Talesun	Talesun modules with 30, 35 and 40mm frames TAByZZaa-xxx-b Where "A" can be D or P; "B" can be 6 or 7; "y" can be blank, F, G, H, I or L; "ZZ" can be 60, 66, 72 or 78; "aa" can be M, M(H), or P; and "b" can be blank, B, T, or (H)
Tesla	Tesla modules with 40 mm frames TxxxY Where "Y" can be H or S
Trina	Trina Modules with 30, 35 and 40mm frames TSM-xxxYYZZ Where "YY" can be DD05, DD06, DD14, DE14, DE15, DE15V, DEG15, DEG15VC, DE18M, DEG18MC, DE09, DE19, DEG19C.20, DE06X, PA05, PC05, PD05, PD06, PA14, PC14, PD14, PE14, or PE15; and "ZZ" can be blank, .05, .05(II), .08, .08(II), .10, .18, .08D, .18D, 0.82, .002, .00S, 05S, 08S, .20(II), A, A.05, A.08, A.10, A.18, (II), A(II), A.05(II), A.08(II), A.082(II), A.10(II), A.18(II), C.05, C.07, C.05(II), C.07(II), H, H(II), H.05(II), H.08(II), HC.20(II), HC.20(II), M, M(II), M.05(II), MC.20(II)
URE	URE modules with 35 mm frames DyZxxxaa Where "D" can be D or F, "y" can be A, B, 6 or 7; "Z" can be K or M; and "aa" can be H3A, H4A, H8A, E7G-BB, E8G-BB or MFG-BB
Vikram	Vikram solar modules with 35 and 40 mm frames XVSyy.ZZ.AAA.bb Where "X" can be blank, Paradea, Prexos or Somera; "yy" can be M, P, MBB, MDH, MDHT, MH, MS, MHBB, or PBB; "ZZ" can be 60 or 72; "AAA" is the module power rating; and "bb" can be 03, 04 or 05
VSUN	VSUN modules with 30, 35 and 40 mm frames VSUNxxx-YYz-aa Where "YY" can be 60, 72, 108, 120, or 144; "z" can be M, P, MH, PH, or BMH; and "aa" can be blank, BB, BW, or DG

## MODULE COMPATIBILITY

Waaree	Waaree modules with 40 mm frames WSyy-xxx where "yy" can be blank, M, or MB
Winaico	Winaico modules with 35 and 40 mm frames Wsy-xxxZa Where "y" can be either P or T; "Z" can be either M, P, or MX; and "a" can be blank or 6
Yingli	Yingli modules with 35 and 40 mm frames YLxxxZ-yy Where "Z" can be D or P; "yy" can be 29b, 30b, 34d, 35b, 36b or 40d
ZN Shine	ZN Shine modules with 35 mm frames ZXY-AAA-xxx/M Where "Y" can be 6 or 7, "AAA" can be 72, NH120, NH144, NHDB144, NHLDD144, SH144, SHDB144 or SHLDD144

## FRAMELESS MODULE LIST

MAKE	MODELS
Astronergy Solar	Astronergy frameless modules CHSM6610P(DG)-xxx
Canadian Solar	Canadian Solar frameless modules CSbY-xxx-Z Where "b" can be 3 or 6; "Y" is K, P, U, or X; and "Z" can be M-FG, MS-FG, P-FG, MB-FG, or PB-FG
Heliene	Heliene frameless modules YYZZxxxA Where "YY" can be 72; "ZZ" can be M; and "A" can be GH
Jinko	Jinko frameless modules JKMxxxPP-DV
Prism Solar	Prism Solar frameless modules BZYY-xxxAAA Where "Z" can be i or N; "YY" can be 48, 60, 60S, 72 or 72S; and "AAA" can be blank or BSTC
Risen	Risen frameless modules RSMyy-6-xxxZZ Where "yy" can be 60, 72, 120 or 144; and "ZZ" can be MDG or PDG
Stion	Stion frameless modules STL-xxx or STL-xxxA
Sunpreme	Sunpreme frameless modules GXB-xxxYY Where "YY" can be blank or SL
Trina	Trina frameless modules TSM-xxxYY Where "YY" can be either DEG5(II), DEG5.07(II), DEG5.40(II), DEG5.47(II), DEG14(II), DEG14C(II), DEG14C.07(II), DEG14.40(II), PEG5, PEG5.07, PEG5.40, PEG5.47, PEG14, or PEG14.40