



# QuickMount® Lynx™ Metal Roof Attachment

## Connect with Confidence

QuickMount® has always been known for high-quality solar attachments and Lynx™ now expands that portfolio into standing seam metal roofs. This roof type can be a great option for many buildings—durable, low-maintenance, and water-tight—with seams to securely attach equipment.

Lynx™ is a robust, non-penetrating clamp for attaching solar. Designed for use with the QuickMount® L-Foot and IronRidge Rails, it offers a complete system on many standing seam roof profiles. Lynx™ can also support other racking platforms, with additional engineering.

Lynx™ is part of a UL 2703 listed system and is integrated with our Pitched Roof Design Assistant software, so you can connect your next system with the utmost confidence.

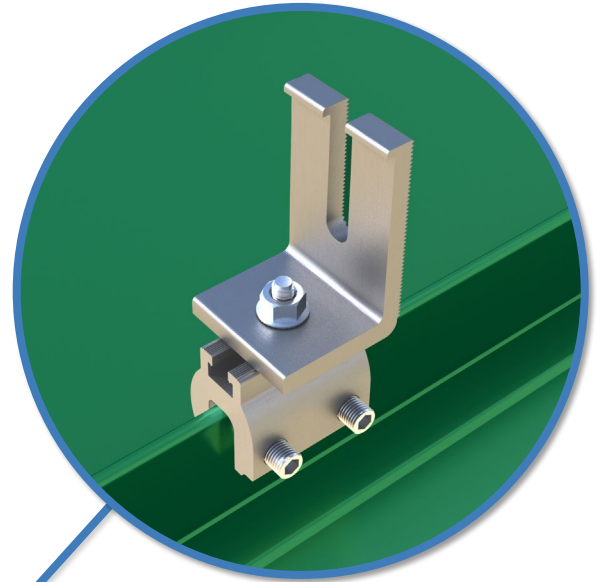

### N-S Adjustability for QuickMount® L-Feet

Lynx™ features an open-ended T-slot for north-south adjustability, to easily line up rails. That means 2" of available adjustment for sliding L-Feet to properly connect them to rails. Coming fully packaged with the attachment hardware, Lynx™ is designed for use with QuickMount® open-slotted L-Feet and IronRidge rails.



This component is part of the QuickMount® product line.

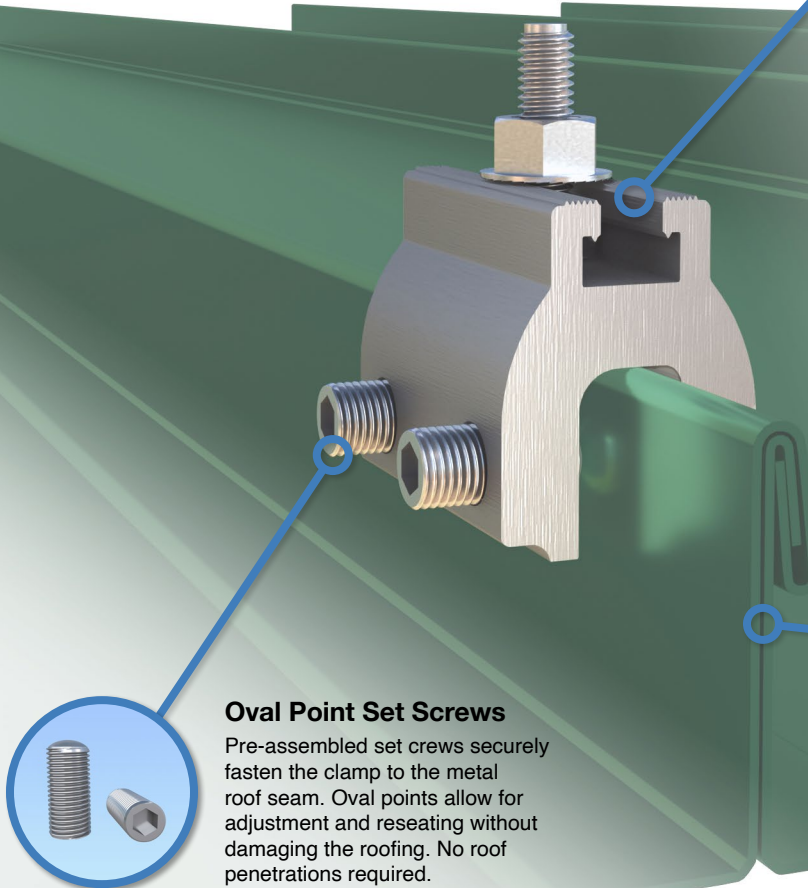

### Oval Point Set Screws

Pre-assembled set crews securely fasten the clamp to the metal roof seam. Oval points allow for adjustment and reseating without damaging the roofing. No roof penetrations required.

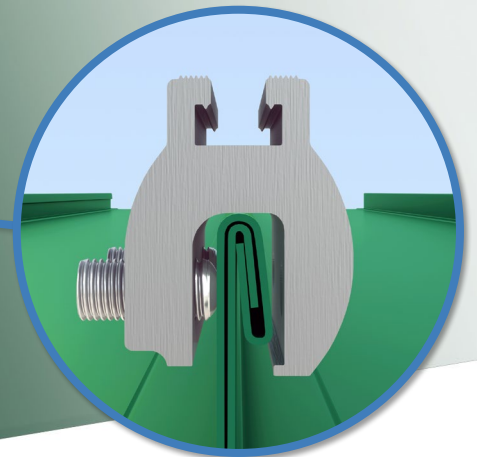

### Vast Standing Seam Compatibility

Lynx™ can be used on a majority of standing seam profiles used for metal roofs, including many snapping and folding standing seams. See backside for a comprehensive guide on the specific standing profiles that fit best.



**25-Year Warranty**  
Product guaranteed free of impairing defects.



## Lynx™ Metal Roof Compatibility

QuickMount® Lynx™ can be used on standing seam roofs (folding and snapping styles) with a vertical seam height of at least 1.0" and a horizontal seam width maximum of 0.5". See the Flush Mount Installation Manual for installation details.

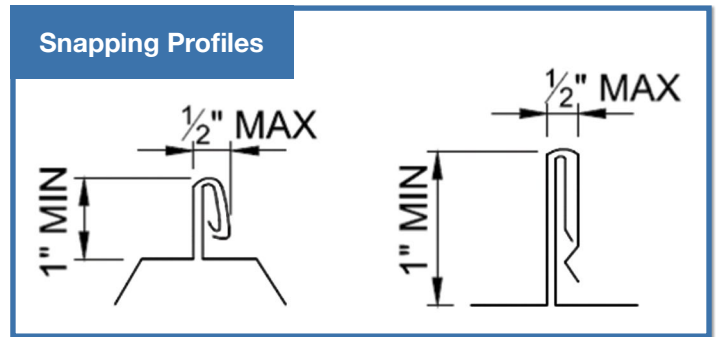
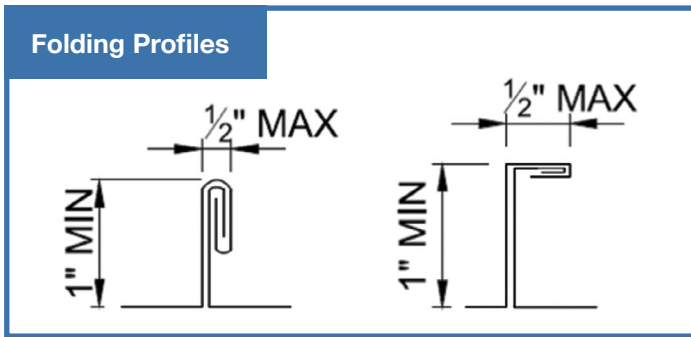

## Lynx™ Racking Compatibility

Lynx™ is part of the QuickMount® family of quality solar attachments, engineered and certified to perform with IronRidge XR Rails—but also performs well under other racking solutions. Consider it on your next metal roof project.

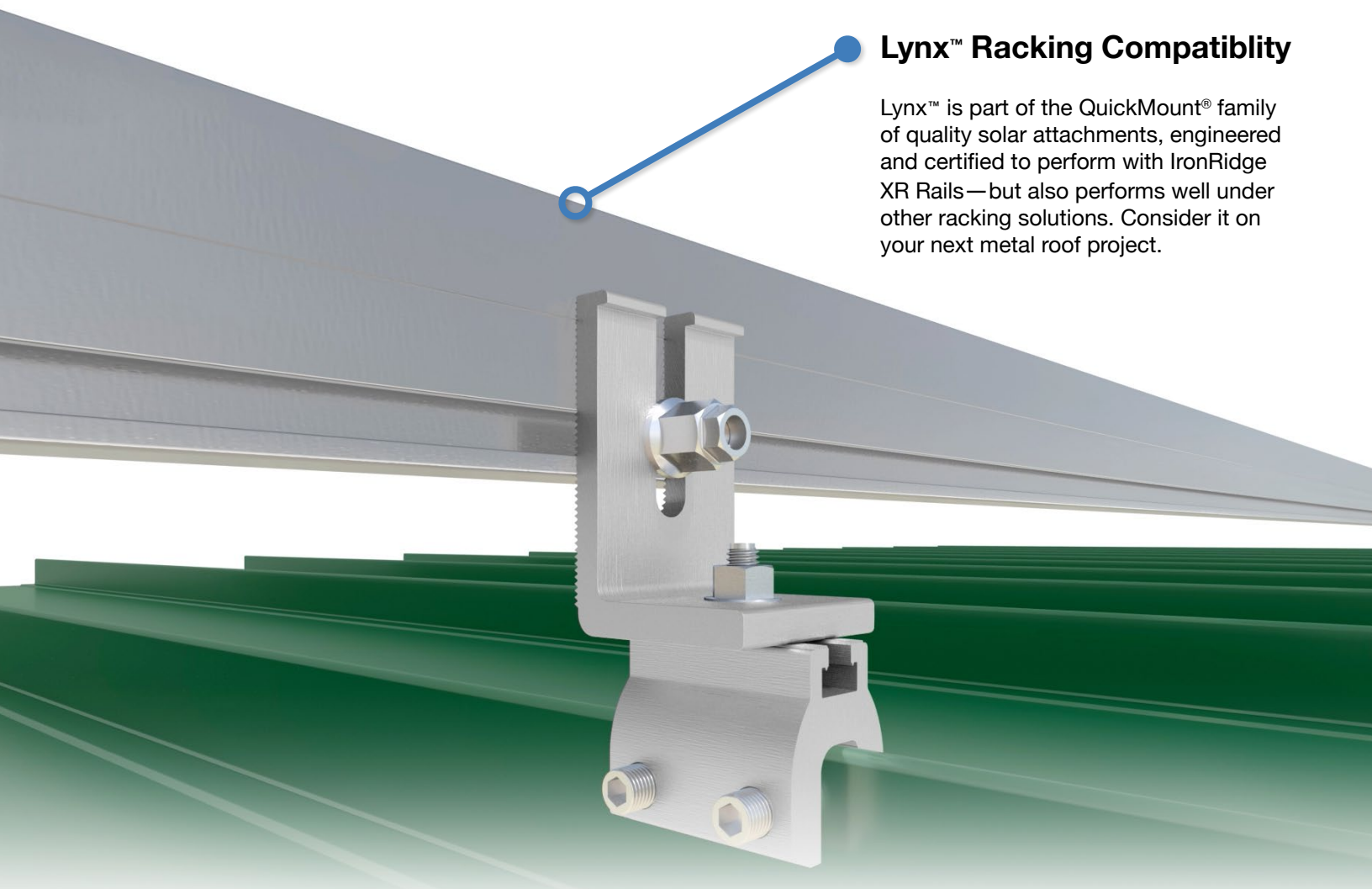

### Included in Design Assistant

Lynx™ is available in our Pitched Roof Design Assistant, along with a stamped certification letter.



### Certification & Testing

Lynx™ is a certified component that has been tested and evaluated to conform with UL 2703.

