



## DIY Manual



## DIY Manual

Welcome to the MidNite Solar DIY Manual, a new series of instructional material to help our Do-It-Yourself friends. Inside this manual is helpful information on wiring and circuit protection; battery bank sizing and installation; the Classic MPPT charge controller; and overall system design guidance and advice. Read, enjoy, learn! As always, call our Technical Support team with any questions you may have pertaining to your MidNite products.

Contents	Page
System Design	2
PV Modules	13
PV Combiners	21
Batteries	28
Wiring and Circuit Breaker Protection	37
Classic Charge Controller	46



# DIY Manual



## SYSTEM DESIGN

Solar system design involves a load analysis, battery bank sizing, solar panel sizing and configuration, charge controller selection, and inverter considerations and sizing. Proper system design ensures balance between battery capacity and panel charge capabilities via the correct charge controller. An “out of balance” system may not meet your consumption needs, or worse may waste money on unnecessary expenditures. Let’s begin!

### Step 1 LOAD ANALYSIS

Designing a solar system starts not with the panels or batteries, but rather with the intended use of the solar system. What do you want to power with the solar energy? A load analysis is an examination of all appliances you intend to operate off the battery bank, both AC loads via an inverter and DC loads direct from the battery bank. Each appliance has a power and time component as a part of the overall equation.

Identify all the appliances to be powered, to include wattage and hours of planned operation during a 24-hour period.

#### Load Analysis Example

<u>Appliance / #</u>	<u>Watts</u>	<u>Hours</u>	<u>Watt-Hours (Wh)</u>
TV / 1	75W	4 Hrs	300 Wh
LED Lights / 3	20W	5 Hrs	300 Wh
Refrigerator / 1	500W	Cyclical	3000 Wh
Toaster Oven / 1	1800W	0.5 Hrs	<u>900 Wh</u>
	<b>Total Watt-hours</b>		<b>4500 Wh</b>



# DIY Manual

If the wattage of an appliance is not known or marked on the appliance, use amps. **Watts = Volts x Amps**. For a 120VAC hair dryer drawing 10A, that will be 1200W (1200W = 120VAC x 10A). Don't forget the time element: If you use the 1200W hair dryer for 10 minutes, your watt-hours for this appliance will be 200Wh (1200W x 1/6 hour = 200Wh).

Refrigerators, freezers, well pumps, et cetera are cyclical loads, turning on and off at random (based on usage). Charts online show the average 24-hour consumption of such cyclical appliances. Be mindful that refrigeration energy usage varies with room temperature. To over-design a system, just in case, you can use the wattage rating of the appliance and multiply by 6 hours for a refrigerator or freezer. For an AC blower motor on your woodstove or furnace, for example, you need to determine realistically how long it will be on. Even though it may have a thermostat which turns it off and on, if you set the thermostat up high, then it will be on longer. So, use common sense and adjust the watt-hour calculations accordingly. If to be cautious you err on the high side, that is OK, but that means higher costs in terms of extra panels and batteries.

*Consider increasing the total watt-hour figure by 20% to account for missed appliances, unknown load usage, and just to give yourself a bit of a buffer, just in case!*

Use of a Watts Up or Kill-a-Watt meter to determine actual energy consumption per appliance is a great way to help determine your real power needs. Most are available for \$20 or less.

The above load analysis example gave us a planned 24-hour consumption of 4500Wh. This number will now be used to determine the size of the battery bank and will be used to determine the size of the solar panel, or photovoltaic (PV), array.

## Step 2 BATTERY BANK SIZING

### Calculate Total Watt-hour Capacity

<i>Depth of Discharge</i>	
<i>Vs</i>	
<i>State of Charge</i>	
<b>DOD</b>	<b>SOC</b>
0%	100%
20%	80%
50%	50%
90%	10%

Most solar systems are designed with a planned depth-of-discharge of 50% for flooded or sealed batteries; Lithium batts are normally discharged to 80% DOD, and some allow up to 100% DOD. That means you will use 50% - 100% of the bank's capacity each day (24 hours), then recharge the bank the next day. For a longer battery bank lifespan, use a lower depth of discharge (DOD), such as 20%, which means you will only consume 20% of the total capacity, not half. The trade-off being more batteries are required to meet your energy needs.

State of Charge (SOC) refers to "How full is the battery bank?" and Depth of Discharge (DOD) refers to "What percentage of the total capacity of energy have I consumed?" The terms/concepts are inversely related.



# DIY Manual

*Panels (or Batteries) in Series – Voltage adds, Current remains the same.*

*Panels (or Batteries) in Parallel – Current adds, Voltage remains the same.*

For a 50% DOD battery bank, multiply 4500Wh by 2 = 9000Wh.

**NOTE:** What does this mean? You want to consume 4500Wh a day and you want to draw down your bank no more than 50%, so you need a bank that is twice as big.

For a 20% DOD bank, multiply 4500Wh by 5 = 22,500Wh.

**NOTE:** Reason for multiplication factor of 5:  $100\% / 20\% = 5$ .  $22,500\text{Wh} \times 20\% = 4500\text{Wh}$ . To consume 4500Wh and only draw down your bank by 20% requires a bank 5 times as large.

## Determine Quantity of Batteries

Now we decide on the number and size of the individual batteries for your bank.

1. Determine watt-hour capacity of the selected battery (i.e., the 6V, 225Ah Trojan T-105 battery):
  - a.  $6\text{V} \times 225\text{Ah} = 1350\text{ Wh}$
  - b. Each Trojan T-105 stores 1350Wh of energy (100% DOD).
2. Determine quantity of batteries required. How many T-105s are needed for our 9000Wh bank (50% DOD bank)?
  - a.  $9000\text{Wh} / 1350\text{Wh} = 6.67$  batteries
  - b. No one makes a 0.67 battery, so round down to 6 (or up to 8).

**NOTE:** Why not round up to 7 batteries? That would make for uneven strings – Not good!

Six T-105s allow for a 3-string 12V bank  $[(6\text{V} \times 2) + (6\text{V} \times 2) + (6\text{V} \times 2) = 12\text{V}]$  but only 4 batteries of the 6 can be used in a 24V bank:  $(6\text{V} \times 4 = 24\text{V})$ . What if you want a 48V bank using the 6V T-105? You will need to buy 8 batteries total  $(6\text{V} \times 8 \text{ batteries} = 48\text{V bank})$ .

## Possible combos to achieve 9000Wh of battery capacity:

- For a single string, 24V bank, switch batteries. Go with four 6V batteries rated at 370Ah, such as the Trojan L-16:
  - $6\text{V} \times 4 \text{ batteries} \times 370\text{Ah} = 8880\text{Wh}$
- For a 2-string 24V bank, select four 12V, 190Ah batteries:
  - $(12\text{V} \times 2) + (12\text{V} \times 2) \times 190\text{Ah} = 9120\text{Wh}$



# DIY Manual

- For a 2-string 24V bank, use eight 6V batteries rated at 190Ah:
  - $(6V \times 4) + (6V \times 4) \times 190Ah = 9120Wh$
- For a 3-string 12V bank, buy six 6V, 250Ah batteries:
  - $(6V \times 2) + (6V \times 2) + (6V \times 2) \times 250Ah = 9000Wh$

**NOTE:** For best battery bank health, avoid more than 3 parallel strings when using flooded or sealed batteries. Too many strings can lead to imbalanced cells due to increased resistance. Most Lithium batteries allow multiple parallel strings. Check with the Li batt manufacturer.

**NOTE:** The above example called for 6.67 batteries at 6V and 225Ah. And combos were given showing how different Ah rated batteries could be used to make the bank. Let's pretend you select the 6V, 225Ah batteries and you only buy 6. Your solar system will be slightly undersized in batteries, and you will not be able to power all loads for the desired length of time. Conversely, if you round the 6.67 required batteries to 8, then you will have excess energy.

## Step 3 PV SIZING

From the load analysis, we plan to consume 4500Wh every day, so that energy needs to be replaced with solar power.

How many solar hours of sunlight are available in your area?

- Solar irradiance charts (easily found online) show the amount of average sunlight across the US. You can use the annual average.
- If you live off-grid, you may want to pick the winter average, which will be fewer hours than the annual average. This in turn will mean a larger system in terms of panels and batteries.
- Let's say your annual average sunlight hours is 4.7 hours.

Now we decide the quantity of the solar panels for your system. Let's use a typical 250W panel. The number of panels required is ...

1.  $4500Wh / 4.7 \text{ hours (of sunlight)} = 957W$
2.  $957W / 250W \text{ (panel)} = \mathbf{3.8 \text{ panels.}}$

**Confirm the math:**  $3.8 \text{ panels} \times 250W \times 4.7\text{hrs} = 4465Wh$ . In other words, 3.8 250W panels in the sun for 4.7 hours will generate 4500Wh (4465Wh) of energy to fill the battery bank from 50% to 100% DOD.

Again, partial components (3.8) won't work, so now we decide to either round down to 3 panels or up to 4. Hmm? Let's put this conundrum on hold for a while; we need to first select the

*Consider increasing the total PV array by 40%: 20% to account for battery inefficiencies AND 20% for solar energy losses due to panel orientation, resistance, atmospheric, dust, and dirt.*



# DIY Manual

appropriate charge controller, which will determine how the panels are wired together, which will bring us back to how many panels can be wired together, 3 or 4.

## Step 4 CHARGE CONTROLLER SIZING

Charge controllers come in two flavors: Pulse Width Modulated (PWM) and Maximum Power Point Tracking (MPPT).

A PWM controller is simple in concept and inexpensive in cost compared to an MPPT controller. PWM means the controller varies the width of the output pulse to the battery bank, thus regulating the charging current through pulse width – wider width means more current. When the PWM controller senses the bank is filling up, the pulses are reduced in width, thus decreasing current flow to the batteries. A PWM controller couples the solar panel output voltage to battery voltage. Therefore, if you have a 12V bank you will want a solar panel with about an 18 Vmp output, for example.

An MPPT controller tracks the solar panel's power curve (IV curve) using an algorithm-driven program to find the highest power point (Vmp) on the curve. The Classic and KID MPPT charge controllers constantly sweep for optimal Vmp.

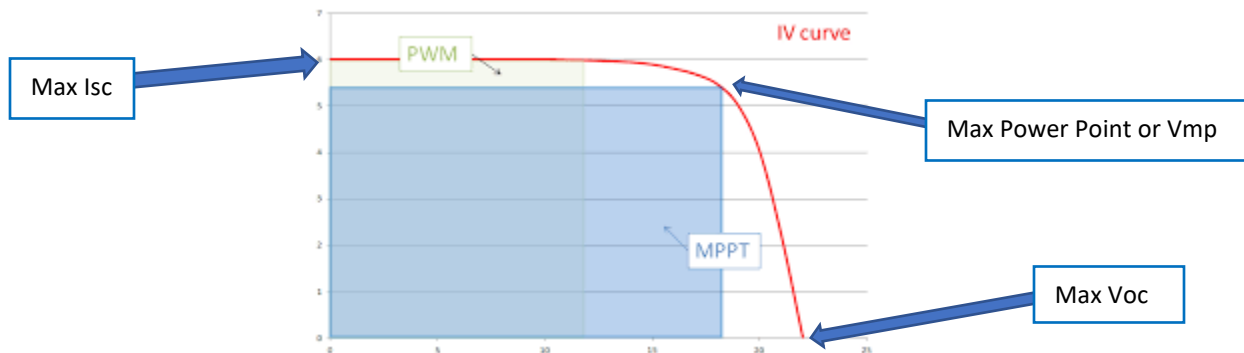

MPPT charge controllers require an input voltage that is 133% higher than the highest battery bank charging voltage (i.e., the Equalization charge voltage). This voltage differential is what generates up to 40% more current than a PWM controller. In a 12V system, the Classic 150 operates optimally with an input of 70-90V. Refer to the Classic Owner's Manual to review the Classic Power Graphs for the Classic 150, Classic 200, and Classic 250 charge controllers for banks from 12V to 72V.

Now we go back to the unanswered question of how many PV panels are needed for our example, 3 or 4 panels? Knowing the input to an MPPT controller must be higher than Batt V, we consider how many panels will be wired in series and presented to the MPPT controller.

Our continuing example calls for 3.8 panels ...



# DIY Manual

1. Assume our 250W panel has a Voc of 37V
2. If we round-down and wire 3 panels in series, we get an input voltage of 111V (37V x 3).
3. If we round-up and wire 4 panels in series, the input Voc will be 148V (37V x 4).

What is the input voltage limit of your charge controller?

If the input limit is 150V, which is common, then you can safely wire up 3 panels in series. But remember, 3 panels are less than your load analysis calls for!

If the input limit is 150V and you wire up 4 panels, the 148V input is so close to the 150V limit, that with cold temps slightly below 25°C/77°F your controller will stop working until the ambient temperature rises enough that the PV array's Voc drops below 150V.

In this example, you are best served by wiring 2 panels in series, the other 2 panels in series, then combine both strings in parallel. OR ... use the Classic 200 which allows for a 200Voc input. However, for a 48V system, we now have a new problem! This 2-panel-in-series configuration gives you an input voltage of 74V (37V x 2 panels in series), which is not high enough to fully charge a 48V bank. Remember, Voc needs to be at least 133% of the highest charge voltage. In a 48V system, the EQ voltage may be 61V. So 61V x 133% = 81V. The 2 panels in series is not quite enough at 74V.

## Cold Temperatures Corrections

Electrons like cold temps! They flow easier. As such, cold temps will raise the Voc of your panels. So be mindful of the series-string Voc of your panels into the charge controller when operating in cold temps. For example, say your series string has a Voc of 141V and the charge controller has a 150V input limit. This leaves little room for colder temps. If the Voc exceeds 150V, both the Classic and the KID charge controllers will go into a self-protection resting mode called HyperVOC. This mode offers protection against an over-voltage condition based on Classic model and battery bank voltage (for the KID, HyperVoc occurs from 150V to 162V). The Classic 150 in 24V offers HyperVoc to 174V (150 + 24).

<i>Correction Factors for Ambient Temperatures</i>	
<b>Ambient Temp</b>	<b>Factor</b>
14 to 10 C	1.06
-1 to -5 C	1.12
-16 to -20 C	1.18

The Brat has no buffer, so do not exceed 60V on the input.

Let's assume your series string into the CL150 is wired at 135Voc and your locale can experience cold temps down to -20C. Multiple 135V by the correction factor of 1.18 = 159.3V. In this example, the Classic will go into HyperVOC until the Voc drops below 150V.



## DIY Manual

### **Which Classic is right for you? 150? 200? 250?**

The Classic's name refers to the maximum input voltage limit in terms of open-circuit voltage, or Voc. For the Classic 150, the limit is 150V; 200V for the Classic 200, and of course, 250V for the Classic 250.

A higher input voltage allows the system to be designed with more PV panels wired in a series string. Remember, voltages add in series and current stays the same. The advantage of wiring more panels in a series string is to keep the total PV current low, which allows the PV array to be physically located a greater distance from the charge controller using smaller physical size wire.

### **The KID and the Brat charge controllers**

The KID is a 30A MPPT controller with a 150V input limit. Perfect for RVs, boats, cabins, and small systems. The Brat is a 30A PWM controller with a 60V input limit. Perfect for small, cost-conscious systems. Both controllers offer advanced features such as load control and equalization of flooded batteries. The KID has an excellent auto generator start function.

Panel wiring considerations for the KID are similar to the Classic, as mentioned above. As for the Brat, match up nominal panels to nominal battery bank voltage. For example, with a 12V battery bank, select a nominal 12V panel, usually about 100W with 21Voc and 17-18Vmp. The 17-18Vmp is what the Brat will drag down to battery voltage to make power. Almost always you will wire panels in parallel with the Brat, exception being the use of small (35W or 50W) panels. Remember, the input voltage to the Brat needs to be slightly higher than battery voltage.

For the PWM Brat controller, select a PV module with a Vmp rating that is a few volts higher than the highest charging voltage for your battery bank. For example, say you have a nominal 12V bank and your battery charges to 16.2V in the EQ mode. Source a PV module with a Vmp rating of at least 18-19V for optimal performance. You can use larger panels, such as a nominal 24V, 250W panel with a 34Vmp rating, for example. Just know - with a Vmp that high above bank voltage the system will be less efficient as the PWM controller has to pull that higher voltage down to the battery charging voltage. Also, wire the panels in parallel to keep Vmp the same, otherwise you will add the voltages and the PWM controller will not be as efficient.

### **How many panels can a charge controller accommodate?**

The MidNite Classic 150 charge controller in 12V can process up to 96A. What is the maximum number of panels that a Classic 150 in 12V can handle?





# DIY Manual

1.  $96A \times 12V = 1152W$
2.  $1152W / 250W \text{ (panel)} = 4.6 \text{ panels}$

**NOTE:** In this example, round down to 4 or up to 6 panels.

What about the Classic 200 in 24V?

1.  $78A \times 24V = 1872W$
2.  $1872W / 250W \text{ (panel)} = \mathbf{7.4 \text{ panels.}}$

## *Classic Current Output Limits*

<b>Classic</b>	<b>12V</b>	<b>24V</b>	<b>48V</b>
150	96A	94A	86A
200	79A	78A	78A
250	61A	62A	55A

**NOTE:** Round down to 6 or up to 8.

The KID and Brat are 30A controllers, so determining the wattage-quantity of panels each can handle is easy:  $12V \times 30A = 360W$ ;  $24V \times 30A = 720W$ ; and  $48V \text{ (for the KID)} \times 30A = 1440W$  of panels. To allow for inefficiencies due to weather, line loss, dust, panel orientation, et cetera, MidNite Solar allows the PV wattage to exceed specifications by 150%. This means total PV wattage in a 12V system can be 500W; 1000W for 24V; and 2000W for 48V.

**NOTE:** Oversizing your PV array to account for inherent inefficiencies may result in excessive heat of the charge controller. Ensure proper ventilation to help mitigate the heat build-up.

## **Concluding with the sizing example and tying it all together...**

Let's revisit all the assumptions and issues ...

1. The load analysis calls for 4500Wh of energy per day.
2. For a 50% DOD battery bank, you need 9000Wh of storage capacity.
3. Using 250W panels, you need 3.8 panels.
4. You round the 3.8 panels up to 4:
  - a. Rounding up ensures you will have enough PV for the 4.7 hours of average daily sunlight.
  - b. But wiring 4 in series presents a potential HyperVoc issue:
    - i. Use the Classic 200 as a solution. Trade-off being the CL200 outputs less current than the CL150.
    - ii. OR ... use slightly larger panels in terms of wattage and wire 3 in series to keep the Voc low enough. Be mindful – higher wattage panels will have a higher Voc.
  - c. Wire up 2 panels in series, then the remaining 2 panels in series, and combine in parallel:
    - i. Wiring 2 of the 37Voc panels in series gives a string Voc of 74V, which is good for 12V and 24V banks, but insufficient to charge a flooded, lead acid, 48V bank.



## DIY Manual

### Another perspective on series strings and Voc ...

From the preceding discussion of the maximum number of 250W panels using the Classic 150 in 12V, we can use 4.6 panels. Let's round that up to 5 panels for this discussion. And let's also assume each panel has a Voc rating of 37V and Isc (short circuit current) of 9A.

So, your CL150 in 12V can handle 5 panels. How to wire them up?

If you wire 3 in series to keep the Voc below the CL150 limit of 150V, that presents a problem in that you will have 3 panels in the first series string and 2 panels in the second series string. Can't do that! Must have same number of panels in each string to keep the string voltages the same.

You must either round down to 4 panels or round up to 6. Now 6 panels will be more total wattage than the CL150 (in 12V) can process, thus you are wasting panels (6 x 250W = 1500W; the CL150 in 12V can only process 1152W). On the other hand, most PV arrays are about 80% efficient, losses due to panel orientation, line resistance, variable sunlight intensity, etc. So, 80% of 1500W (if we use the 6 panels) = 1200W, very close to the max Classic 150 limit of 1152W in a 12V system. Therefore, 6 panels will actually be very productive considering the inherent losses.

*Voltage Drop = Decrease in voltage due to higher resistance in longer wire lengths.*

*$V$  (Volts) =  $I$  (Current) x  $R$  (Resistance) ... If resistance increases and current stays the same, then  $V$  must lower (drop).*

You can wire all 5 panels in series for a Voc of 185V and an Isc of 9A. Having only 9A of current allows your PV array to be placed a good distance away from the Classic. Assume the best spot to build your PV ground-mount is 100 feet from the charge controller. 9A over 100 feet with a 3% voltage drop requires a #4 AWG wire. If you had wired 4 panels in series/parallel, the total current would be 18A; therefore, over the same 100 feet, you would need #2 AWG wire.

Now, 5 panels in series gives a Voc of 185V. That will not work with the CL150. The CL200 will work in warm environments, as will the CL250. 185V into the CL200 offers little wiggle room, though, for cold temps, which raise the Voc.

**NOTE:** The above examples of current, wire length, and voltage drops are generic. Refer to the Wiring and Circuit Breaker Chapter of the DIY Manual for more information on calculating current and sizing wire.



# DIY Manual

## Step 5 INVERTER SIZING

The final step in our system design is to size the inverter to power all your loads. Let's look again at the Load Analysis Example.

<u>Appliance / #</u>	<u>Watts</u>	<u>Hours</u>	<u>Watt-Hours (Wh)</u>
TV / 1	75W	4 Hrs	300Wh
LED Lights / 3	20W	5 Hrs	300Wh
Refrigerator / 1	500W	Cyclical	1500Wh
Toaster Oven / 1	<u>1800W</u>	0.5 Hrs	<u>900Wh</u>
<b>Total Watts</b>	<b>2395W</b>	<b>Total Watt-hours</b>	<b>3000Wh</b>

If you want to power all the loads at the same time, then you will need an inverter capable of continuously providing at least 2395W, which is the total wattage of the appliances: 75W + 20W + 500W + 1800W = 2395W.

Of all the appliances in our example, the refrigerator is the only one with a motor or compressor, which will draw more current upon start-up. Thus, we must factor in surge capacity. General rule of thumb is 3X the rated wattage. For the refrigerator, that means 1500W (3 x 500W).

For continuous duty and to power all the appliances listed above, we need at a minimum a 2500W inverter that can surge momentarily to 3500W (which is the extra 1000W for the refrigerator at start-up). Most inverters will surge to at least twice the continuous duty wattage.

### Well Pump

*A well pump can surge to 3x the normal running current. This surge will be short in duration and will momentarily lower the battery voltage due to the initial surge. If the pump runs during the early morning hours when the batt voltage is low, this may trigger the inverter to shutoff. When sizing a system, ensure the batt bank is of sufficient Ah to accommodate the surge and size the batt bank in terms of Wh, as mentioned in the Load Analysis, for the repeated cycling of the pump over a 24-hour period.*



# DIY Manual

## MIDNITE SIZING TOOL

Our Sizing Tool (<http://www.midnitesolar.com/sizingTool/displaySizing.php>) is a great way to verify your proposed solar system design. Plug into the tool the variables from your PV modules (sticker on the back side of the panel), ambient temp data, battery bank nominal voltage, and how you plan to wire the PV (series and/or parallel), then hit the “Submit Parameters” button. Pay attention to the “Max Voc,” “Array Power (Wattage),” and the “Classics Required” results. Max Voc and Array Power should have a green “OK.” The “Classics Required” can be up to 1.2 and that is fine with a single Classic.



Temperature  C°  F°

**PV Module Data (STC)**  
(Found on back of module or spec sheet)

Power (Watts)

VOC (Open Circuit Voltage)

VMP (Maximum Power Point Voltage)

ISC (Short Circuit Amperage)

IMP (Maximum Power Point Amperage)

VOC Temperature Coefficient C° (Default is -0.33%)  %

VMP Temperature Coefficient C° (Default is -0.45%)  %

**Environmental Data**

Coldest Ambient Temp C°

Hottest Ambient Temp C°

Nominal Battery Voltage (Volts)

**PV Array**

Number Of Modules In Series

Number Of Parallel Strings

Total Modules

[Reset](#)

[PRINT RESULTS](#)

PV Array			
Rated PV Array Power:	880	Watts	
Anticipated Array Power @ 40C:	821	Watts	
Rated PV Array Current:	15.74	Amps	
Battery Charging Current @ 57.6 V:	15.3	Amps	
VMP (Maximum Power Point Voltage) :	61.2	Volts	
VOC (Open Circuit Voltage):	75.2	Volts	
VMP @ -30 C°:	76.4	Volts	
VOC @ -30 C°:	88.8	Volts	
Classic, Classic SL & Classic Lite Charge Controller Selection			
	150	200	250
Max Operating Voltage	150	200	250
Max Non operating VOC (HyperVOC) @ 48V Nominal Battery Voltage	198	248	298
Maximum Number Of Modules In Series	3	4	5
Max Number Of Modules In Series (Using HyperVOC)	4	5	6
Max Allowable Output Current Per Classic Based On This Current Configuration	86	78	55
Max Allowable Wattage Per Classic Based On This Current Configuration	5022	4550	3212
Present PV Array Wattage Of This Configuration	880	880	880
Design Check			
Max VOC	OK	OK	OK
Temperature The Classic Will Enter HyperVOC	-276 C°	-478 C°	-679 C°
Array Power (Wattage)	OK	OK	OK
Classics Required	0.2	0.2	0.3

NOTE: MidNite Solar recommends a second controller be added after 1.2

NOTE: Generally speaking you'll want to use the Classic 150 or 200 as they are less expensive and will handle more power. With MPPT controllers the higher the input voltage the less efficient they are. This is not a large value but it will add up to a little more heat in the controller and a point or two less in efficiency. BUT you also have to be careful not to have the input voltage too low. Most all MPPT controllers will want to see a minimum of 130% of the actual high battery voltage. So if we have a 48v battery and it has an Equalize voltage of 62.3 volts then we would multiply that by 130% and we would need a minimum of 81 volts on the input on the hottest day of the year in order to have enough headroom for the MPPT to work.

WARNING: MidNite Solar makes no representation, warranty or assumption of liability regarding the use of the String Calculator. This tool uses data provided by other parties (such as PV module specs) and makes calculations based on assumptions which may or may not prove to be valid.



# DIY Manual



## PHOTOVOLTAIC (PV) MODULES

A basic solar system consists of solar panels, a charge controller, and batteries. This chapter of the DIY Manual focuses on the solar panels, or photovoltaic modules, or simply PV.

Photovoltaic – “Voltage produced by (sun) light.”

### UNDERSTANDING PV MODULES

A solar panel is made of individual silicon cells, wired in series to produce a specific output voltage. Typical panels are made in 60- or 72-cell configurations. 3 types of panels:

1. **Polycrystalline:** cells are made of composite silicon. Usually less expensive per watt than monocrystalline panels, and slightly less efficient than mono. Poly panels are discernable by the medium to dark blue tint of the cells.
2. **Monocrystalline:** Manufactured from a single silicon block, mono panels have a near black appearance, are usually a bit more expensive than poly panels, and are more productive in low light conditions, such as early morning/early evening hours and during cloudy conditions.
3. **Thin film:** Least productive type of panel, therefore more costly per watt compared to mono or poly panels. Where extreme ambient temps are a concern, thin film works best in very hot and cold environment. Thin film is flexible and impact resistant, making it a good choice for boats, solar backpacks, and to minimize damage from vandalism.

Panels are manufacturer-tested under Standard Test Conditions (STC): exposure to artificial light at the intensity of 1000W per square meter at 77° F (25° C). Results of the test are recorded on a sticker found on the backside of the PV module.

- **Voc** – Open Circuit Voltage. Maximum voltage output, used to determine max series-string input voltage to the charge controller. Read Wiring and Circuit Breaker Protection chapter of this Manual for more

ELECTRICAL DATA   STC*	
CS6P	260P
Nominal Max. Power (Pmax)	260 W
Opt. Operating Voltage (Vmp)	30.4 V
Opt. Operating Current (Imp)	8.56 A
Open Circuit Voltage (Voc)	37.5 V
Short Circuit Current (Isc)	9.12 A
Module Efficiency	16.16 %
Operating Temperature	-40°C ~ +85°C
Max. System Voltage	1000 V (IEC) or 1000 V (UL)
Module Fire Performance	TYPE 1 (UL 1703) or CLASS C (IEC 61730)
Max. Series Fuse Rating	15 A
Application Classification	Class A
Power Tolerance	0 ~ +5 W





# DIY Manual

information on Voc and sizing the charge controller's input. Voc is maximum when Isc is at zero.

**NOTE:** Voc will increase in temps below the STC of 77° F, and decrease when temps are above 77° F. In cold climates, Voc may increase to 125% of string voltage, so consider that when designing a system. Refer to the MidNite Classic String Sizing Tool for help ... [MidNite Solar - Classic Sizing Tool](#).

- **Vmp** – Maximum Power Voltage. Maximum voltage output when the PV module is performing at the maximum power point on its Power (IV) Curve.
- **Imp** – Maximum Power Current. Associated with Vmp. Max current at same point.
- **Isc** – Short Circuit Current. Associated with Voc. Maximum output current when Voc is zero.

**NOTE:** Panel values derived during STC testing rarely occur in the real world. You can expect to see slightly lower values for volts, amps, and module wattage. Common average performance of PV panels facing south and properly angled is 80% of the total array wattage. If mounted flat (i.e., on an RV), then you can expect 50-65% of the total array wattage.

## Measuring Volts and Amps

You can measure voltage and current of the panel by itself without it being connected to the entire solar system.

To measure voltage – Expose the solar panel to sunlight, connect multimeter red probe to the panel's positive wire, and multimeter negative probe to its negative wire. This is Voc.

To measure current – Cover the panel with a blanket and connect the panel's positive wire to its negative wire, forming a closed loop of the module itself. Using a clamp-on type of ammeter (or a Fluke meter with appropriate amp circuit), measure current. This is Isc. Remove the blanket to measure Imp.

**NOTE:** Use of blanket, before making electrical connection or disconnection, prevents sparking at the MC-4 connectors. Voltage will be present (hence the spark), but no current flows.

*Panels in Series: Voltage adds, Current stays the same.*

*Panels in Parallel: Current adds, Voltage stays the same.*

## WIRING PV MODULES

Solar panels can be wired in series, parallel, or a combination of series and parallel, depending on the desired input voltage to the charge controller.

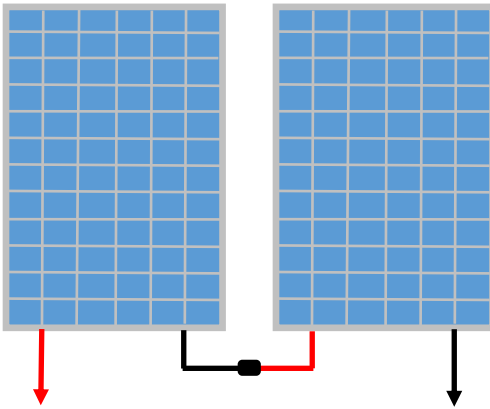

Figure 1: Series

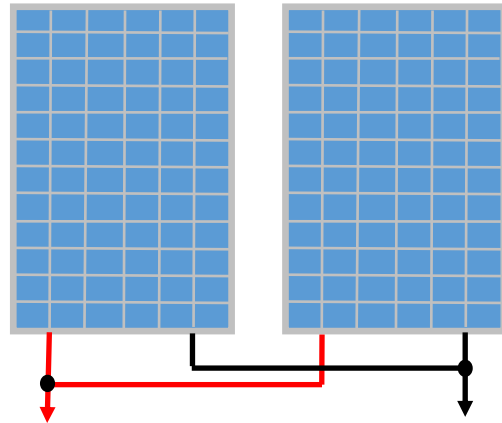

Figure 2: Parallel

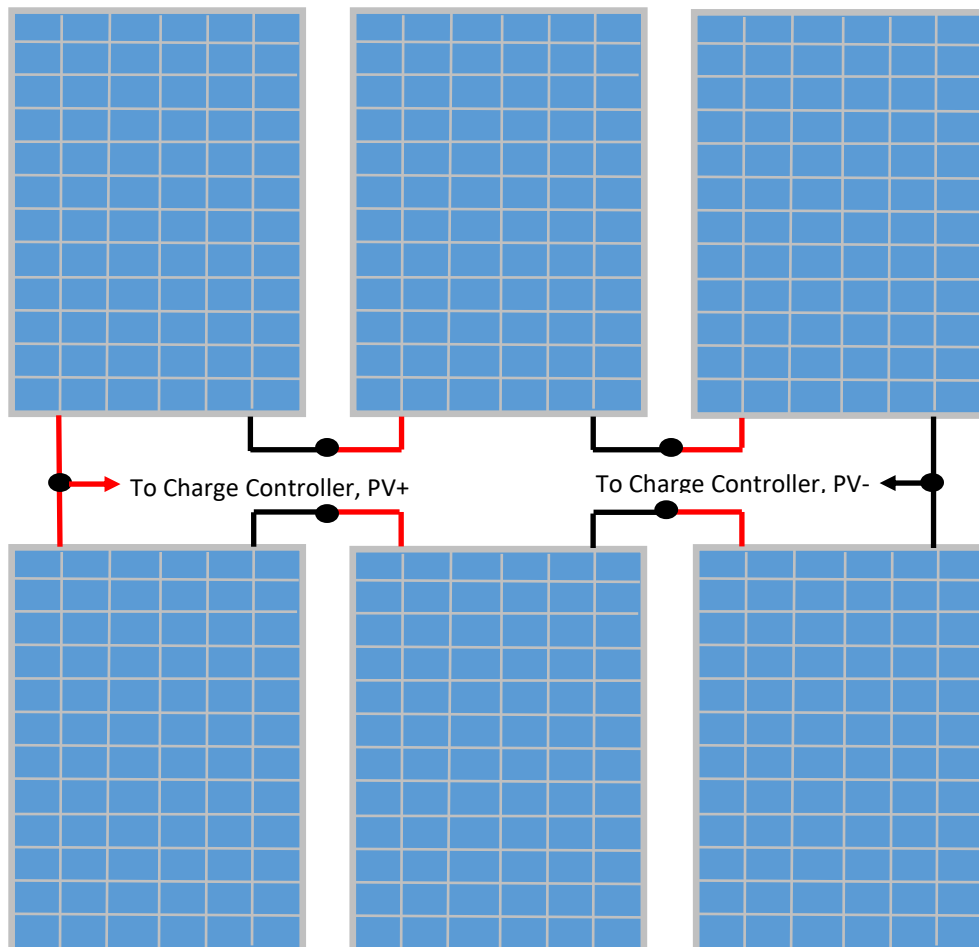
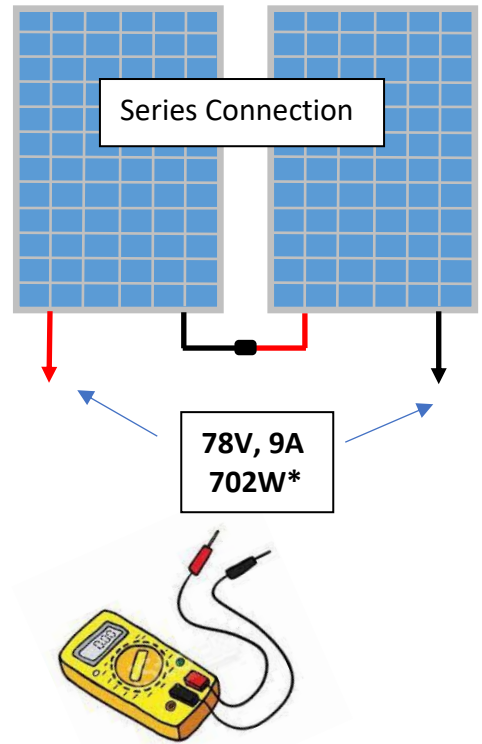

Figure 3: Series & Parallel

To wire panels in series, is to connect one panel's positive wire to the next panel's negative wire. Positive-to-negative is a series connection, and the individual panel voltage adds.

**Example:** Voc = 39V; Isc = 9A. If the Voc is 39V, then 2 (in series) x 39V = 78V.

The PV string voltage is now 78V, as measured by a multimeter via the string's positive and negative connections. And the string current remains the same as for one panel (9A per panel, and 9A for the string).



**\*NOTE:** Wattage shown at 702W for both series and parallel arrays shows the wattage stays the same regardless of how the panels are wired. However, at max Voc, the current is actually 0A. Conversely, at max Isc, the voltage is 0V. Thus, the wattage is 0W when these max theoretical values are used.

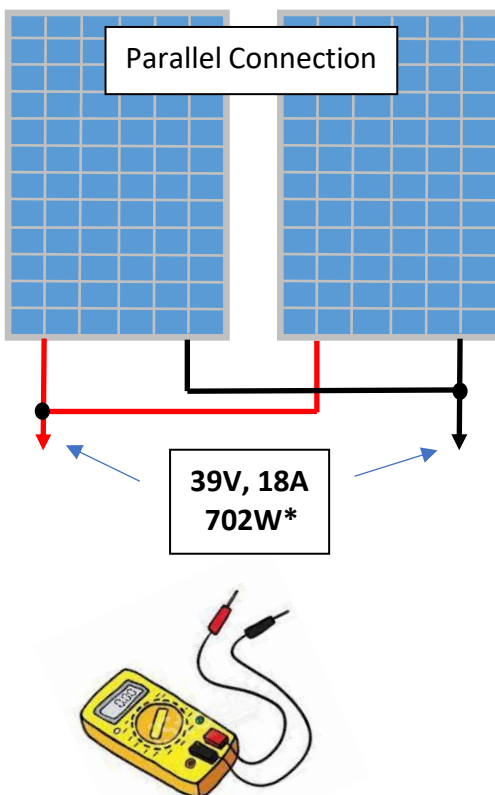

To wire panels in parallel, is to connect one panel's positive wire to the next panel's positive wire. And the negative to negative.

Positive-to-positive, and negative-to-negative is a parallel connection, and the individual panel voltage remains the same, yet the current adds.

**Example:** Voc = 39V; Isc = 9A. The PV string voltage is 39V and the array current is now 18A (2 strings x 9A).

**NOTE:** This arrangement is now called a "PV array." This array is comprised of 2 strings. Although each string only has 1 panel, this is still a 2-string array.



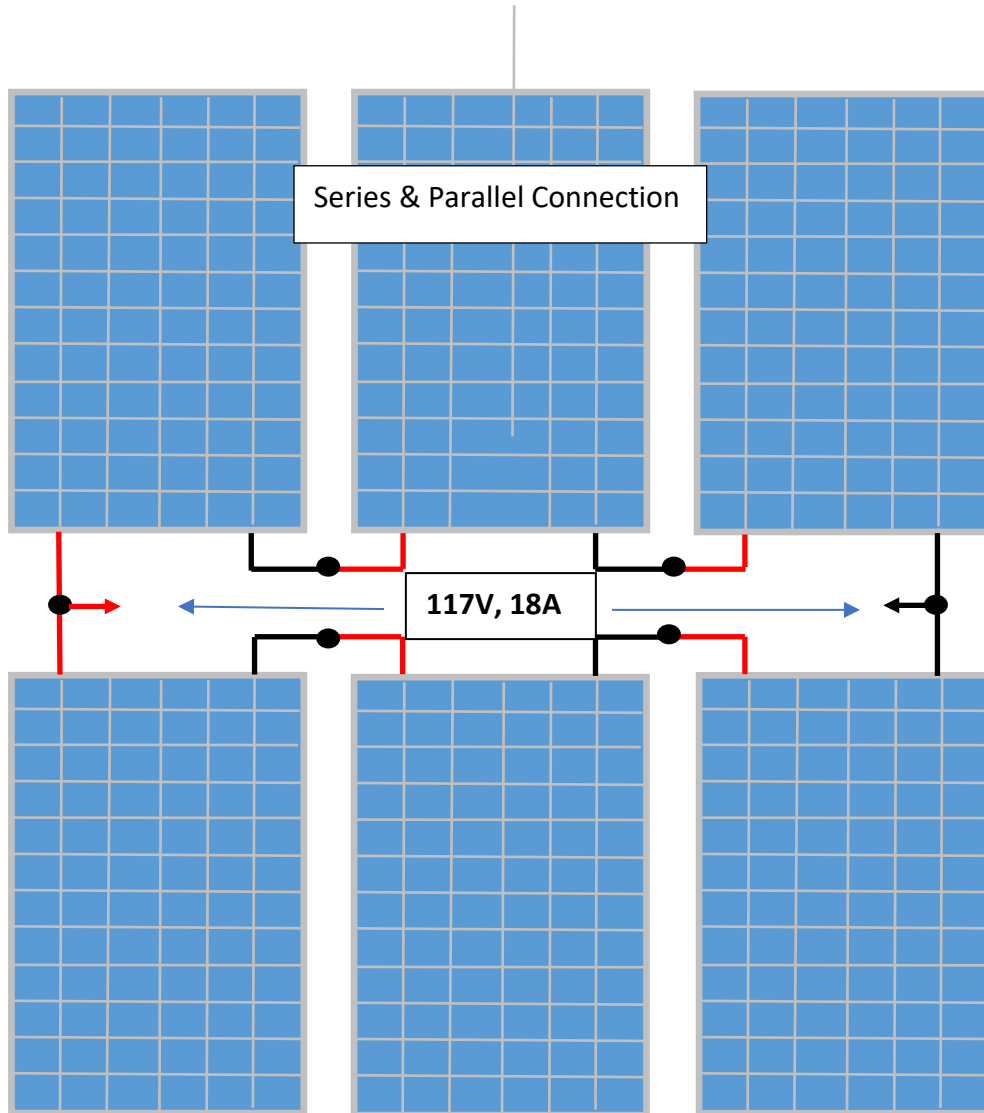



# DIY Manual

A combination of series/parallel is the most common manner to configure PV arrays when using a charge controller, such as the Classic or KID.

Example PV specs: Voc = 39V; Isc = 9A; Wattage = 250W

This array has the following specifications:

- String voltage - 117Voc (3 x 39V)
- String current - 9A
- Array voltage - 117Voc
- Array current - 18A (2 x 9A)
- Array wattage – 1500W (6 x 250W)

## PV Panel Design – Factors and Considerations

Determining how many panels to buy, which panels to buy, how to wire them up, how many in series, how many in parallel, how many combiner boxes are needed ... all those considerations must be simultaneously considered along with, “Which charge controller do I need?” and “How many charge controllers?” and “What is the voltage of my battery bank?” That is why this section on PV Design is important, to explain how to tie together all these disparate factors into one final PV solution!

### EXAMPLE:

- PV wattage needed – 8000W
- Batt bank voltage – 48V
- PV module Voc – 42Voc
- PV module Isc – 9.2A
- PV module wattage – 340W

In this example, we assume you found a good deal on these 340W panels, you bought a bunch of them, and now you need to figure out the PV array. This approach is backwards, but commonplace, hence this example.

The correct flow in designing a solar system is as follows:

1. Conduct load analysis;
2. Size battery bank;
3. Determine quantity of PV wattage to re-charge the batt bank; and
4. Select charge controller and determine PV array configuration concurrently.



## DIY Manual

As you can see, selecting and buying PV panels comes last. So, let's make this work with the new 340W panels you bought!

1. Most PV arrays are about 80% efficient. If you need 8000W of panels, then you actually need  $8000W \times 1.25$  (the inverse of 80%) = 10,000W of PV.
2.  $10,000W / 340W = 29$  PV panels. 29 is an odd number, so that either goes up to 30, maybe down to 27. Maybe 26. We don't know yet, so let's move on for now.
3. The Voc is 42V. The batt bank voltage is 48V. Since you plan to use the MidNite Classic, you know it needs a PV input voltage that is at least 33% higher than the highest batt charging voltage. So, look at the batt manufacturer's spec sheet for your new batts. They are sealed batts, so the highest will be Absorb, and that is at 59.2V, for example.
4. So,  $59.2V \times 1.33 = 78V$ . Thus, the PV string needs to be wired to offer more than 78V. If you wire 2 of these new panels in series, that is  $2 \times 42Voc = 84V$ . That is enough for now, but maybe not when it gets warm! At about 97F, that 84Voc will lower to about 78V, thus being marginally close to the point that the Classic will not work. Let's get that PV voltage higher then!
5.  $3 \times 42Voc$  (3 panels in series) = 126Voc. This is high enough that warm temps will not impact it. But cold temps will raise the voltage. And when the string voltage exceeds the input limit of the charge controller (150V in the case of the Classic 150), then the controller will either rest and protect itself (like the Classic) or be permanently damaged. At -5 to -13F, the PV string voltage of 126Voc will reach 151V. Bottom line ... if this installation location will not see temps colder than -5F, then these panels, wired 3 in series, will work fine with the Classic 150.

**NOTE:** PV voltage is influenced by temperature: cold temps raise the string voltage; warm temps lower the voltage. The Classic charge controller has a special feature called HyperVoc. The Classic will self-protect if the string voltage exceeds the Classic's input voltage limit + battery bank nominal voltage. Example: A Classic 150 on a 24V system will self-protect if the PV input is between 150V-174V (150V + 24V).

6. Now we know the first element of the PV design – 3 panels will be in series to make the desired 126V. Therefore, the PV array has to be in multiples of 3: 3, 6, 9, 12, 15, 18, etc.
7. Remember, we need 29 panels. So,  $29 / 3 = 9.6$  strings. How many panels will the Classic 150 handle?
8. The Classic 150 in 48V can make 86A max.  $86A \times 48V = 4128W$ . Again, most arrays are 80% efficient, so  $4128W \times 1.25 = 5160W$  of PV wattage can be handled by one Classic 150 in a 48V system.
9.  $5160W / 340W = 15.1$  panels. With 3 wired in series, we now know the first array needs 15 panels, thus 5 parallel PV strings (3S/5P = 15 panels).



# DIY Manual

## Conclusion:

- 8000W of PV is needed. Take that up to 10,000W for losses.
- 29 panels are needed. With 3 in series and 5 strings per Classic, round 29 up to 30 panels total.
- 15 panels per Classic 150.
- You need two Classic 150s (Use Follow-Me for charge coordination).

## Selecting the Right Combiner

A combiner box is used to combine, or parallel, PV strings together. A combiner electrically combines multiple PV strings and makes one PV output.



The MidNite MNPV3 Combiner - shown on left with 3 DC circuit breakers with the combining busbar at the top, connecting the PV strings into one output. The MNEPV series breaker is the most popular way to combine strings up to 300VDC. The picture on the right shows the MNPV3 with 1000V fuseholders and a combining busbar. **DO NOT** open a fuseholder under load (when passing current).

## COMBINER EXAMPLE:

From the previous exercise above, we know the following PV details:

- 3 panels in series at 117V
- String current is 9A
- 5 strings to combine

So, which combiner is best for this install?

1. The combiner needs to hold 5 circuit breakers.
  - a. MNPV6 Combiner holds up to 6.
2. The circuit breaker needs to safely handle 117V.
  - a. The MNEPV breakers are rated to 150VDC.
  - b. The MNEPV-300 breaker is rated to 300VDC.
3. The circuit breaker needs to safely handle 11.25A (9A of  $I_{sc}$  x 1.25 (per NEC) = 11.25A).
  - a. The MNEPV15 is correct.



**Answer** – the MidNite Solar MNPV6 combiner, with 5x the MNEPV15 circuit breakers (stock MNPV6 picture below shows with 6 breakers).



## DIY Manual



### PV Combiners

“Why You Need a Combiner”

#### Combining (Paralleling)

Shown on the right is the MidNite Solar MNPV3 Combiner, configured on the left with 3 circuit breakers and a busbar; and on the right with 2 fuseholders and a busbar. The busbar combines (parallels) the PV strings into one common output.

The combiner offers over-current and reverse current protection, to be discussed later, but it also offers a simple and easy manner to combine PV strings. Additionally, since each PV string has its own breaker, that breaker can act as an ON/OFF switch to individually isolate one or more strings for troubleshooting purposes.

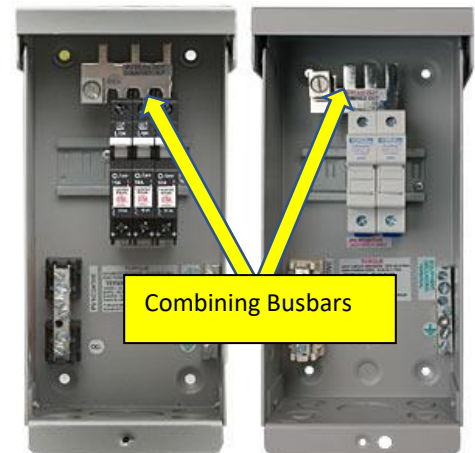

MidNite circuit breakers and fuseholders are rated to carry **100%** of the rated current. A MidNite 100A breaker can continuously carry 100A – no safety de-rating required. Be aware, breakers manufactured by others may **NOT** be rated to carry the full current. A breaker can be opened under load (that means when current is flowing through it) but a fuseholder **CANNOT** be opened under load. It will be damaged! DC breakers from MidNite are designed to capture and extinguish the DC arc caused by opening or closing a DC circuit under load. A fuseholder is not designed to capture the arc, thus it has no where to go. Opening a fuseholder under load, depending on the amount of current, can damage the fuse and the fuseholder.

Do NOT open a fuseholder under load!!!

## Paralleling (Combining)

Solar panels are wired together in one of three ways: 1) Series; 2) Parallel; 3) Series-parallel combination.

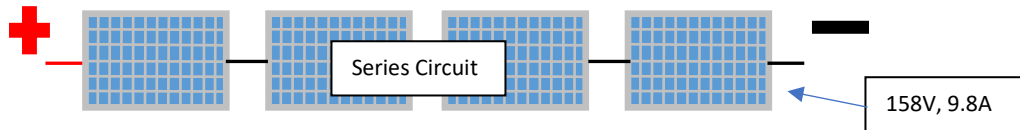

- 1) **Series Circuit:** Wire the panels using their attached wires in this fashion ... positive-to-negative, positive-to-negative. It's like a daisy-chain down the string. At the end of the string (left side in the diagram above) is the string's positive wire; on the right side is the string's negative wire. Effectively this string is one big solar panel. In a series circuit, the voltage adds and the current remains the same. If each panel has the specifications of 39.5Voc and 9.8A Isc, then the series string above is effectively one solar panel with the specs of 158V at 9.8A.

Series Circuit – Voltage adds, Current stays the same.

- 2) **Parallel Circuit:** A parallel circuit is wired positive-positive, and negative-to-negative. Look at the diagram below. See how the two PV panels are wired at the ends, positive-to-positive, negative-to-negative? That is parallel. With the same PV specs, the top panel, we can call that String 1, is still at 39.5Voc, 9.8A. So is String 2 – the bottom PV panel. But the new PV array, now wired in parallel, has the specs of 39.5V, 19.6A.

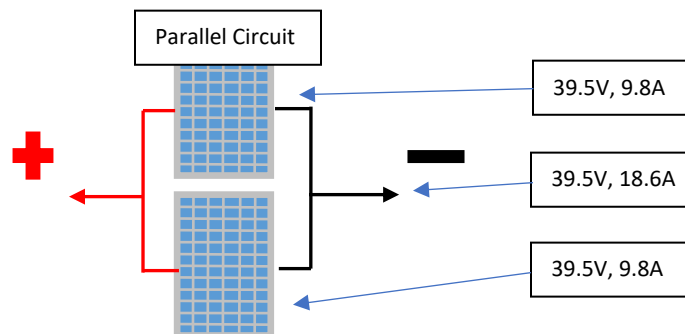

Parallel Circuit – Voltage stays the same, Current adds.

3) **Series-Parallel Circuit:** A series-parallel configuration is basically like it sounds ... PV panels wired in series, and two or more PV strings wired in parallel.

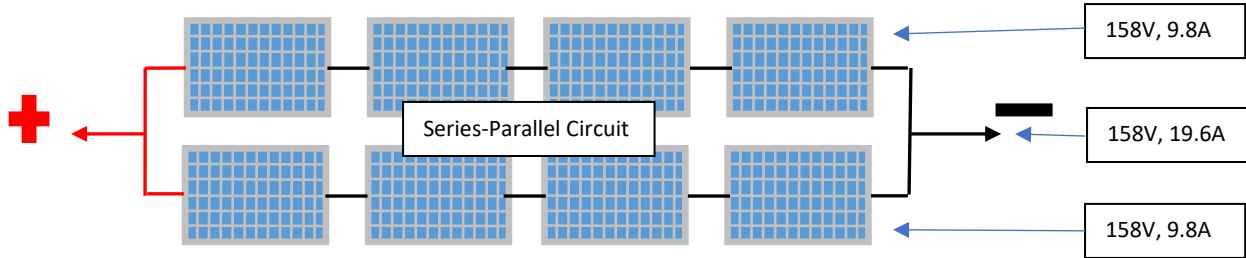

To conclude, combining or paralleling is a wiring configuration to join multiple PV panels or strings to create one common electrical output – PV positive and PV negative – while maintaining the string voltage. Remember -- in parallel the voltage stays the same. The MidNite combiner box is an excellent means of combining (paralleling) multiple PV panels or strings to achieve one PV positive and PV negative output to the charge controller.

## Reverse-Current Protection

A short circuit in a PV module, faulty wiring, or a related fault may cause reverse-current in PV strings. This occurs if the open-circuit voltage of one string is significantly different from the open voltage of parallel strings connected in the same PV array. The current flows from the healthy strings to the faulty one instead of flowing to the inverter or charge controller. Reverse-current can lead to dangerous temperature rises and fires in the PV module.

There is no risk of reverse current when there is only one PV string. When there are two strings with the same number of PV modules connected in parallel, the reverse-current will be always lower than the maximum reverse current. The National Electrical Code (NEC) Article 690.9 requires reverse-current protection when 3 or more PV strings are in parallel.

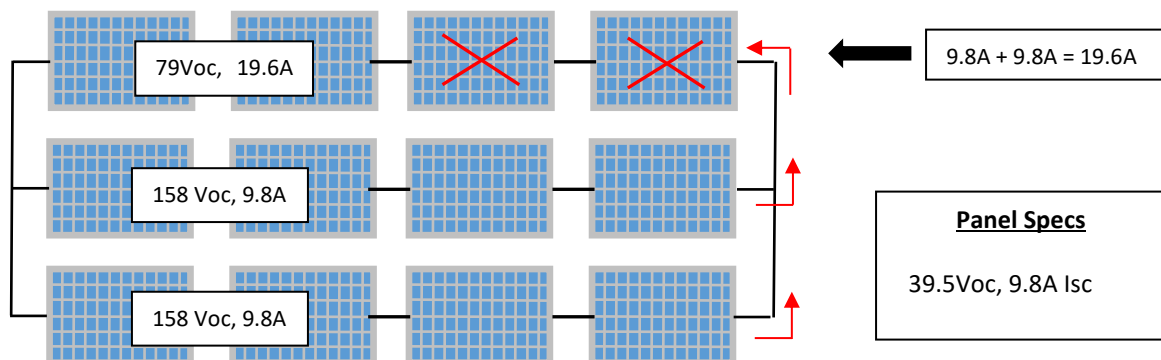



# DIY Manual

Shown are 3 parallel strings, each at 158Voc and 9.8A. String 1 suffered a failure with two PV panels, the string voltage dropped to 79V, and reverse current from Strings 2 and 3 now flows into String 1. Each module has a maximum current rating of 15A; as you can see, String 1 now has 19.6A flowing across it, thus exceeding its max limit. Over time this excess current will cause the wire in String 1 to heat up, and eventually lead to the insulation of the wire breaking down and internal damage to the panels.

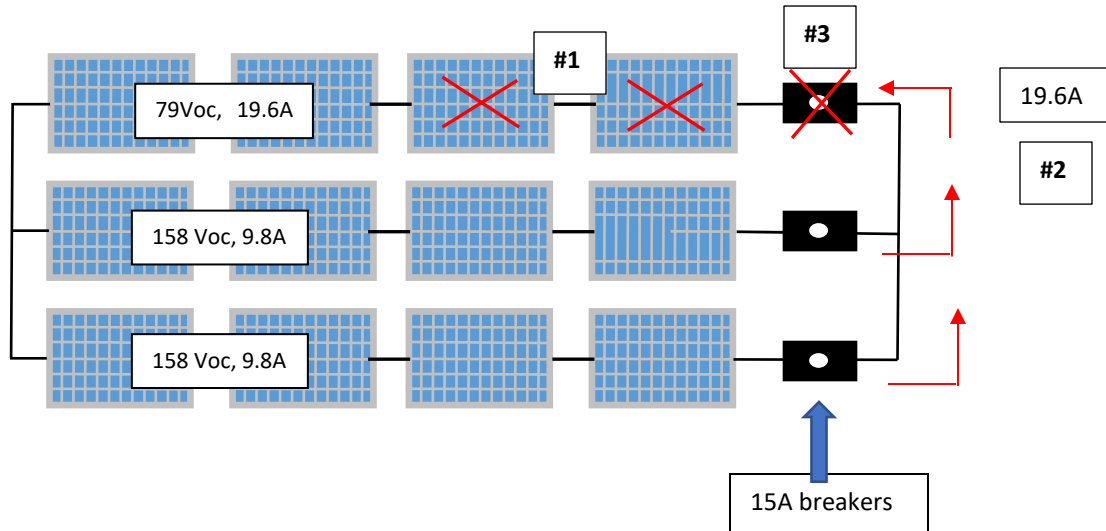

In the above diagram, we added three 15A breakers to each parallel string. How we selected 15A will be discussed later on. Below describes the sequence of events:

- #1 – Two panels fail in the top string, voltage bias changes, current reverses.
- #2 – The current from the other two strings adds to 19.6A, and flows into the top string (reverse-current flow).
- #3 – The top string's 15A breaker sees 19.6A and trips open, thus protecting the wire in the top string from passing current higher than what it is rated to safely pass.

This is why you want string breakers – to protect from a reverse-current situation.

Use string breakers when combining 3 or more parallel strings! NEC 690.9

## Over-Current Protection

A wire of a certain size can carry a certain amount of current, measured in amps. For example, a #10 AWG wire can safely carry 30A. If a circuit can supply more current than the wire can safely





# DIY Manual

carry, then friction caused by resistance will raise the wire temperature which eventually leads to failure of the wire's insulation (the outer protective covering).

NEC Article 690.8 requires that a PV conductor be rated at 125% of the PV source current. For example, you want 30A continuous, so you need a wire that can handle 37.5A (125% of 30A). Instead of using #10 AWG rated at 30A, you use a #8 AWG which is rated for 40A. Thus, your 30A circuit will flow through the #8 AWG wire without heating it up.

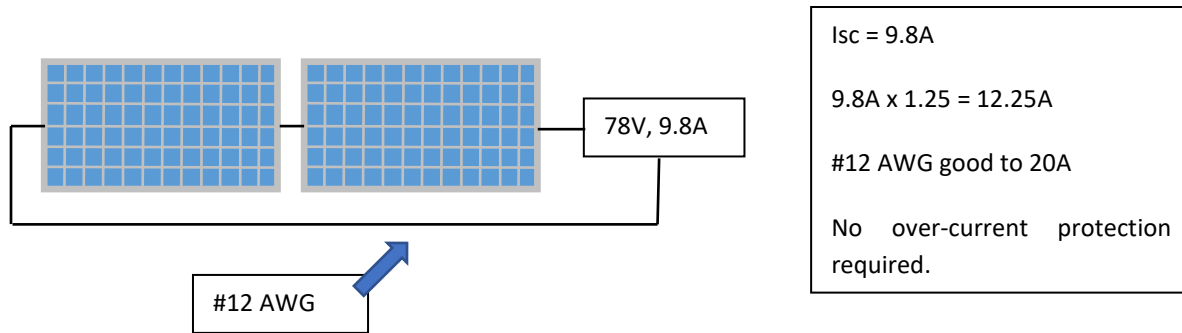

In the diagram above, no OCP is required. The PV current is 9.8A, corrected to 12.25A (1.25 x 9.8A), traveling through a #12 AWG wire rated for 20A. Good to go!

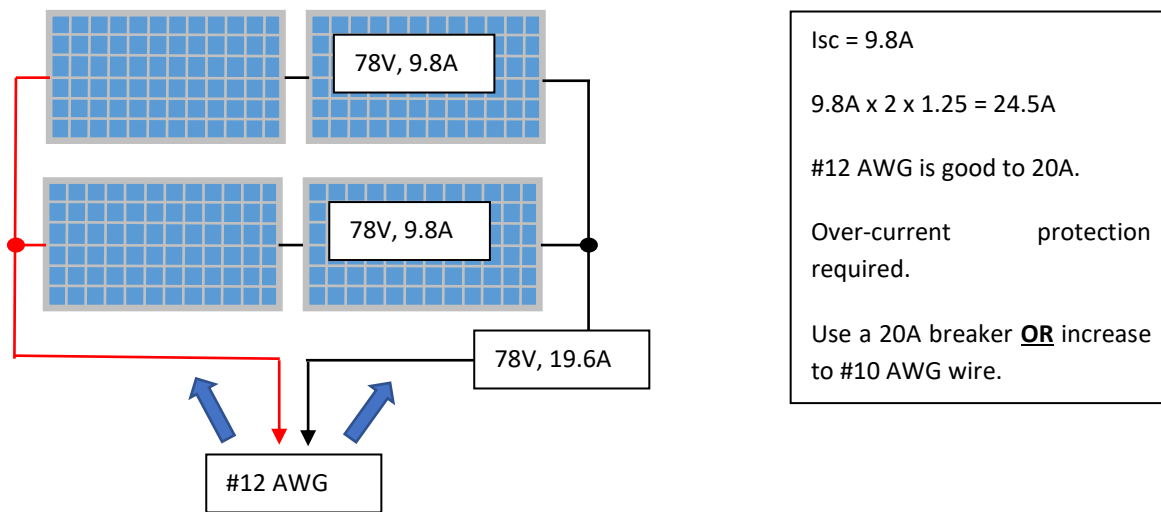

The diagram above presents a different situation. The combined PV source current is 19.6A, corrected to 24.5A (1.25 x 19.6A). If the wire gauge from the nodes down is #12 AWG, then OCP is required. A 20A breaker is required to limit the current to the ampacity of the wire. To limit the current is to limit the solar production, so that would be bad design. You bought the panels,



# DIY Manual

you want their full wattage! So, you would want to increase the wire size to #10 AWG, which can safely carry up to 30A.

## Over-Current Protection – Breaker Sizing

NEC 690.9 requires that over-current protective devices (breakers, fuses) be rated to handle not less than 125% of the maximum currents. If the over-current protective device is rated for continuous duty (called the 3-Hr Rule), then the amp rating of the device can be at 100% or equal to the maximum currents.

Using the same diagram we saw before, the combined maximum current is 19.6A.

Adjusted current is 24.5A (1.25 x 19.6A)

### Breaker sizing:

- For non-continuous duty breaker:  
 $1.25 \times 24.5A = 30.6A$
- For continuous duty breaker:  
 $1.00 \times 24.5A = 24.5A$

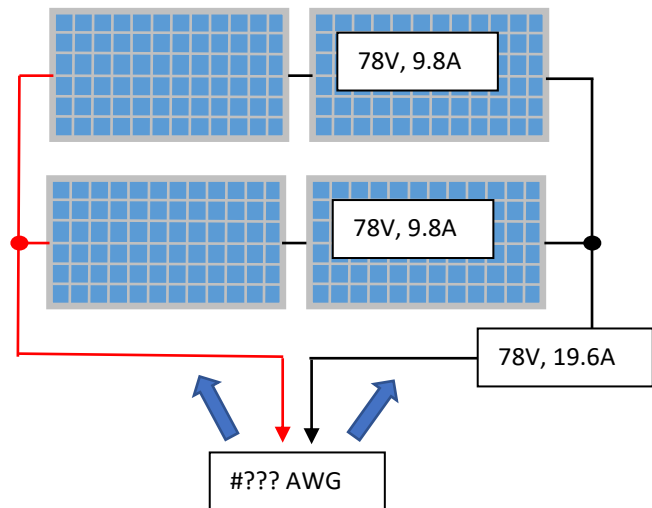

*MidNite Solar breakers and fuses are rated at 100% continuous duty!*

Since MidNite breakers are rated at 100%, we can use a 24.5A breaker, which does not exist. In the above example, in real life, you would use #10 AWG for the PV homeruns connected to a 30A breaker.

The NEC allows over-current protection to be located at one end of the PV source circuit. In the system block diagram below, we have a combiner box, #2, with two 15A breakers serving as OCP devices. We also have what is called the “PV Input Breaker,” #6. This could also be the OCP device. In most installations, the combiner is located at the PV array, say a ground-mount system, some distance away from the house. In that case, the #6 breaker acts as a simple ON/OFF switch so that you do not have to walk out to the PV array to turn off the combiner breakers. It is common to select the breaker for #6 slightly over-rated, so it will not nuisance trip. Continuing with the example PV strings above, with an  $I_{sc}$  of  $9.8A \times 2$  strings, we know the adjusted PV amps



# DIY Manual

is 24.5A. Therefore, if you elect not to use the combiner, then #6 must be a 30A breaker. If you use the combiner, then #6 can be rated higher than 30A, such as a 40A breaker.

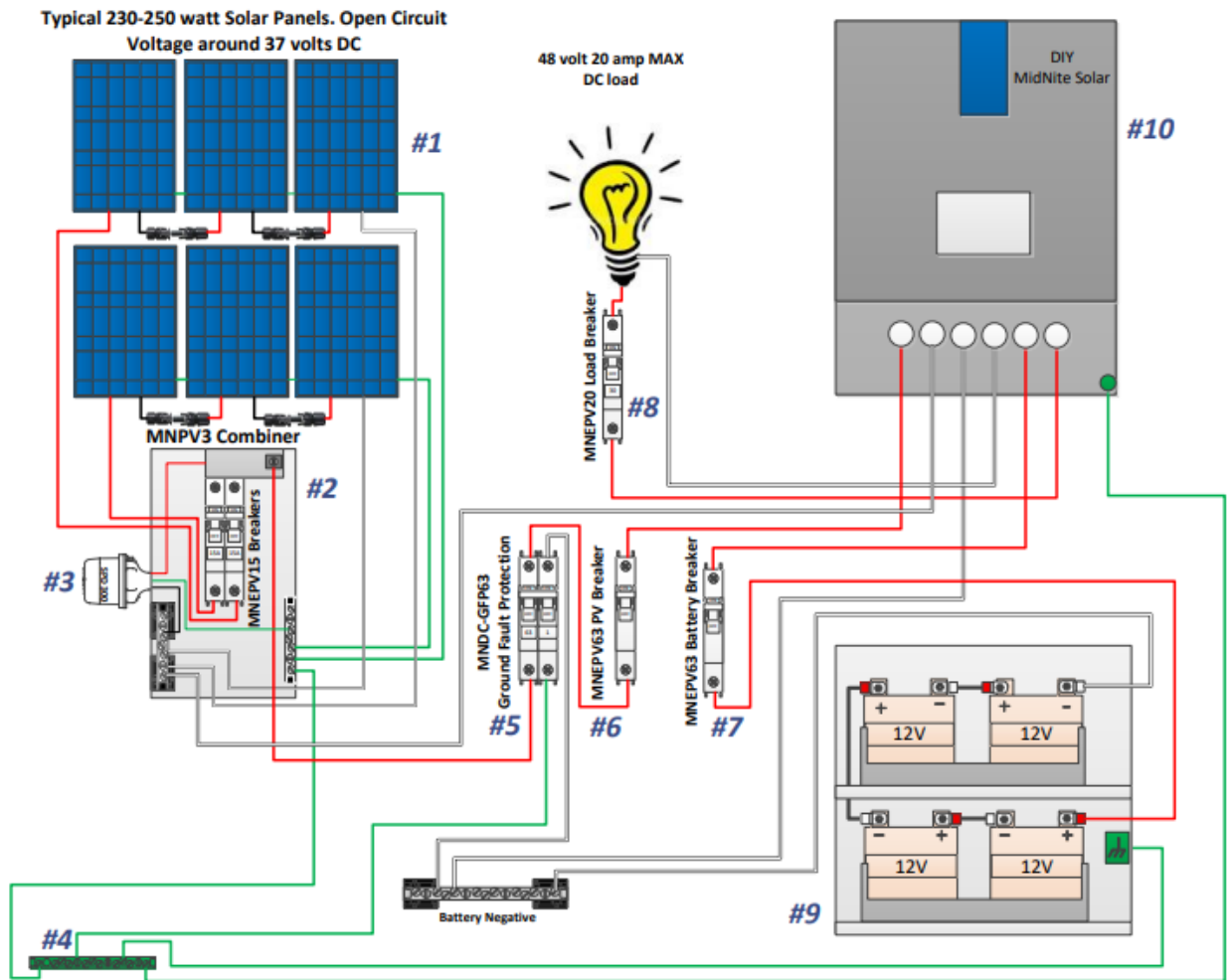



# DIY Manual



## BATTERIES

A battery bank can be 1/3 cost (or more) of your solar system, so battery choice is important in terms of budget, longevity, and performance. Considerations when choosing a battery type include cost, voltage and amp-hour capacity of the individual battery and the overall bank, placement in or outside of the dwelling, cold temperatures, charging rates, and future expansion.

### BATTERY TYPES

**Flooded** – Typical, wet cell battery type; lead plates suspended in electrolyte. Identifiable by removable cell caps on top of battery.

#### PROs

- Inexpensive
- Equalization allowed
- Can add distilled water

#### CONs

- Outgasses hydrogen and oxygen
- Store fully charge to prevent sulfation
- High self-discharge rate
- Not ideal for standby use

**GEL / AGM** – Both are sealed battery types, sometimes called SLA – sealed lead acid, SVR – sealed valve-regulated, or VRLA – valve-regulated lead-acid. Gel uses an electrolyte with consistency of petroleum jelly; AGM, or absorbed glass mat, uses glass fiber material to trap the liquid electrolyte. AGM performs better than Gel in cold temps.

#### PROs

- No outgassing
- Battery orientation
- Deeper discharge (80%)
- Faster charge rate
- Ideal for standby use

#### CONs

- More expensive than flooded
- Usually cannot equalize
- Sensitive to over- and under-charging
- Shorter lifespan than flooded

**Lithium** - New battery chemistry, popular in electric cars and smart phones. Requires a Battery Management System (BMS) to regulate charge amongst cells. Lithium batteries are very sensitive to over-charging – a BMS is critically important.

#### PROs

- Deep discharge (100%)
- Maintains high voltage level

#### CONs

- Most expensive
- Need for protection, BMS



# DIY Manual

*Most Lithium batteries are manufactured with a BMS built-in to the battery itself. Some Lithium batts are simply a bunch of Lithium cells soldered together in series without a BMS. The BMS acts like a “traffic cop” to regulate the individual charging of each Lithium cell in terms of voltage, current, and temperature. Therefore, the BMS needs to be designed for the cells. Avoid a homemade Lithium battery with an over-the-counter, generic BMS.*

- No memory issues
- Low self-discharge
- Degrades at high temps
- Sensitive to charging voltages

## BATTERY PLACEMENT

Consideration should be given for proper battery bank placement in terms of serviceability, ventilation, temperature control, and proximity to other system components.

**Serviceability** – You will at times need to access all the batteries in the bank for maintenance, such as adding electrolytes, checking specific gravity of each cell, measuring voltages, or replacing batteries. Give yourself room to access all batteries.

**Ventilation** – Store flooded batteries in a ventilated space, as they outgas hydrogen sulfide (highly corrosive and deadly in high concentrations) and oxygen, both highly flammable gasses. If your bank is housed in a battery box, incorporate a vent system with upper discharge and lower intake. Consider using a small fan to expel gasses.

**Temperature Control** – Most all batteries lose capacity in cold weather, usually below 77F. Design your system with insulation to keep the batteries warm. Good idea to use a battery temperature sensor from the charge controller manufacturer to regulate charging voltages based on battery temperature. AGM, Gel, and Lithium batteries can sometimes (local code may not allow) be located within living areas.

*The National Electrical Code prohibits installing batteries directly below an inverter system due to access issues.*

*Limit the electrical separation from batts to charge controller, and batts to inverter, to no more than 8 feet.*



# DIY Manual

**Proximity** – This means physically locating the batteries near associated solar system components, such as the charge controller and inverter, to minimize the length of DC cabling between components.

## BATTERY CAPACITY

Battery capacity refers to the amount of stored energy in your battery bank. In other words, how much energy is available to run your AC or DC loads and for what length of time. The unit of measure for battery capacity (energy storage) is amp-hours.

Amp-hour capacity is denoted with values such as a 5-, 10-, 20-, and even a 100-hour amp-hour rating. When shopping and comparing deep cycle batteries for your solar system, use the 20-hour rating, as this is the most common rating, ensuring you an apple-to-apple comparison.

Charge and discharge rates of a battery are called C-rates. A battery with a C-rate of 1C means that a fully charged battery rated at 1Ah should provide 1A for one hour. 20-hour batteries have a C/20 rate. For a 370 Ah battery, for example, the discharge rate will be 18.5A ( $370 \times 0.05$ , which is  $1/20$ ) for 20 hours ( $18.5A \times 20 \text{ hours} = 370Ah$ ). However, as the load increases, the realized capacity decreases.

### State of Charge & Depth of Discharge

State of Charge (SOC) refers to “How full is the battery charged?”

Depth of Discharge (DOD) refers to “How low is the battery drained?”

SOC	DOD	12V Bank	24V Bank	48V Bank
10%	90%	11.5V	23V	46V
50%	50%	12.1V	24.2V	48.4V
100%	0%	12.75V	25.5	51V

The table above shows SOC/DOD percentages and the associated bank voltages of a bank of flooded or sealed batteries at rest – not charging or discharging (inverting). Lithium batteries will have a different SOC/DOD scale relative to battery voltage; consult the Lithium battery manufacturer. If your solar system were designed to support a 50% DOD, then it is helpful to know that 12.1V (in a 12V bank) is the equivalent voltage of a bank that is half full, for example.

The per cell voltage of an average flooded lead-acid battery is a nominal 2V per cell, ranging from 1.75V for a fully depleted battery (SOC = 0%) to 2.45V for a fully charged battery under charge. A nominal 6V battery will have 3 cells ( $2V \times 3 \text{ cells} = 6V \text{ battery}$ ).

#### 1. **Know Your Voltages**

- a. Always measure battery voltage when at rest.



# DIY Manual

- i. At rest means no charging (solar) or discharging (inverter)
- ii. Best to wait 30 – 60 mins after last charge or discharge operation.
- b. Batteries under charge will show a higher voltage than when at rest.
  - i. Batteries need higher voltage during charging to induce current to flow into the batteries.
- c. Batteries being discharged will show a lower voltage than when at rest.

## 2. Monitor Your Voltages

- a. Assume your 12V system was designed for 50% daily DOD.
- b. Develop a habit of checking your system voltage at same time every morning and at night (before going to bed is perfect, as you will normally reduce loads at this time).
- c. Let's say this morning the voltage reads 11.9V. 11.9V is below 12.1V (the 50% equivalent of half full), meaning too much power was consumed overnight and the batteries are below 50% DOD.
  - i. Solution – Consume less power after the bank is fully charged **OR** increase amp-hour capacity of your battery bank.

*Depleting flooded batteries below 50% will shorten their lifespan.*

## BATTERY CHARGING

Batteries charge in 3 stages:

1. Bulk – From 0% to about 75% SOC. Bulk is a varying voltage stage, constant current (or as much current as the charge controller can produce).
2. Absorption – From about 75% to 95% SOC. During Absorb, the voltage is held constant and the current slowly decreases to a point where the batteries are full and can take no more current. This is called Ending Amps.
3. Float – 95% to 100%, Float maintains the batteries at 100% SOC.

Equalization (EQ) is a maintenance mode to reduce sulfates that attach to the battery's lead plates during charge and discharge cycles. The charge controller will hold a near constant voltage during the EQ cycle, with varying current.

Obtain from your battery manufacturer a spec sheet that shows the correct charge voltages for your battery model. You should also ask for their recommended ending amps, although many manufacturers do not provide this figure. If not, use 1% - 3% of the overall bank's amp-hour capacity for ending amps.

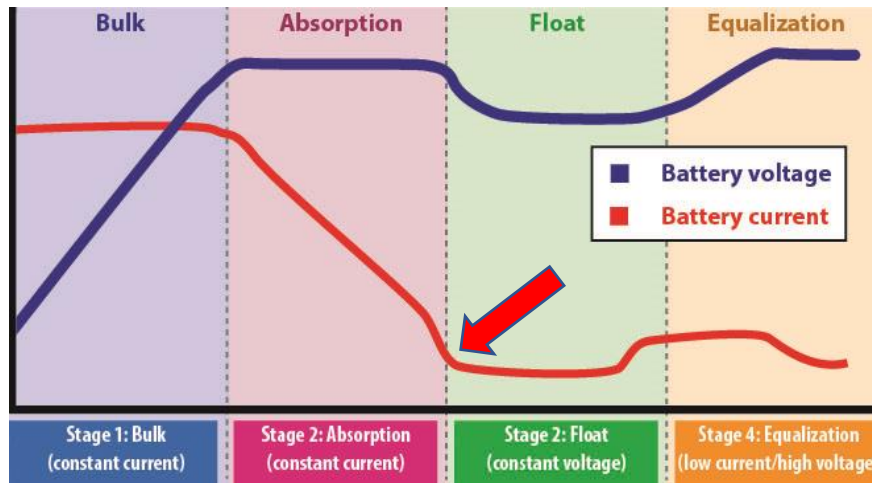

## Ending Amps

The red arrow above indicates the point during the Absorb cycle at which the current has decreased to its lowest level; that is ending amps, which means the batt bank is full. That is the point that you want the charge controller to transition to Float.

As stated, ending amps for most batteries is 1 – 3% of the bank’s 20-Hr, Ah rating. If you want to precisely determine the ending amps for your batteries, then perform the following steps:

1. Set Ending Amps (Charge/Advanced menu) to 1A.
2. Monitor the WBJr Status page during the Absorb cycle
3. Watch for the amps reading below “Whizbang” to stop decrementing. This value is the actual ending amps for your batts. This is the amount of current that cannot flow any more into your batts at the fixed Absorb voltage setting relative to the batt’s internal resistance. It’s the point that your batts are in balance or harmony internally.
4. Change ending amps from 1A to this observed amp setting. Depress Enter to save the change.

If you chose to terminate the Absorb cycle using ending amps, then set the Absorb timer in your charge controller to a value higher than normal; add another 60 minutes to it. This ensures the ending amps are reached first before the timer expires. The Classic and KID will change to Float based on whichever occurs first – ending amps or timer expiration.

Both the Classic and the KID allow for either its internal shunt to be used to calculate ending amps or an external shunt (with the MidNite current-sensing device called the Whiz bang Jr). If you use the internal shunt, the controller will only know the current going into the battery bank; it will not know the amount of current leaving the bank. Why is this important?





# DIY Manual

Let’s say your Classic is producing 30A into the battery bank, your inverter is consuming 20A, your ending amps is set to 8A, AND you use the internal shunt. The net difference is 10A (30A – 20A) going into the bank but on the Main Status page the Classic displays 30A into the bank, so this may be misleading to you. The 30A shown on the Main Status page needs to decrement to 8A for the Classic to transition to Float. But this may or may not happen due to the demand (outgoing 20A) on the system. So, your Classic is making 30A and that current value is not decreasing at the normal rate, as you expect it to eventually drop to 8A and go to Float.

Now let’s assume you are using an external shunt with the Whiz Bang Jr. On the 4<sup>th</sup> Status page you will see the current differential displayed, in this case the 10A differential. When this value decrements to 8A (ending amp setting), the Classic transitions to Float. Now you have a way to observe your system in operation and know when it will or should go to Float. Mathematically the Classic will go to Float at the same time in both scenarios. But with the external shunt and the Whiz Bang, Jr, now you have a better understanding of the current in and out of your system.

## PLANNING YOUR BANK

Rules to keep in mind for a healthy battery bank ...

- A battery bank comprised of a single series string charges and discharges better than a bank of parallel strings.
- Do not add new batteries to a bank of batteries that are more than one year old.
- If you replace batteries, replace all in the same string.
- Use same battery type and size. For example, do not mix flooded lead acid with AGM; do not use a 100Ah battery with a 250Ah battery.

### Series versus Parallel

As mentioned, a single series string is best. Say for example you are new to solar and building your first system. You start off with a 12V bank because you already own a 12V inverter which is sitting on the shelf waiting to be used. OK, you can buy a single 12V battery. Or you can buy two 6V batteries and wire in series to effectively make a “single” 12V battery.

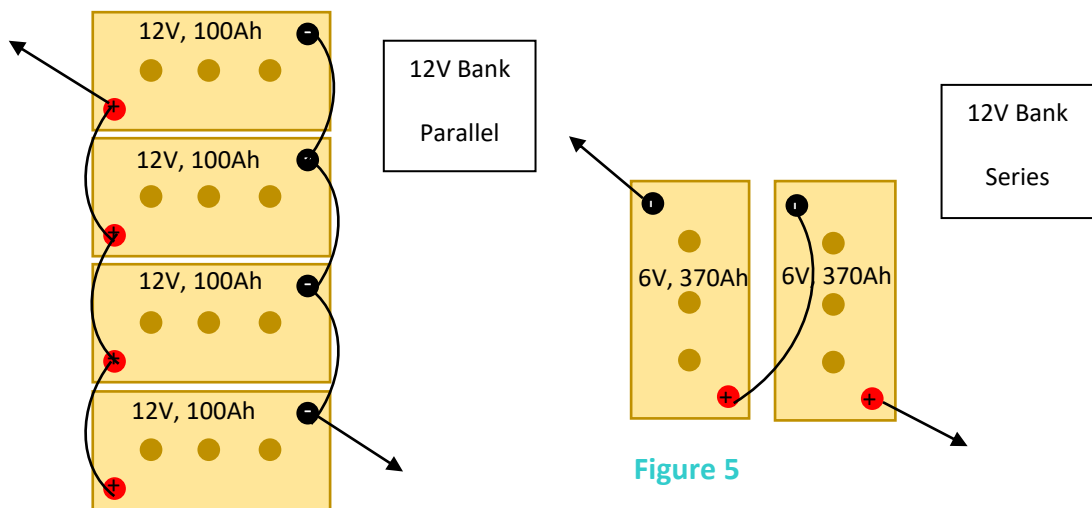

Figure 4

Figure 5



## DIY Manual

Let's do some math! Assume you bought a single 12V, 100Ah battery. That gives you 1200Wh (12V x 100Ah) of storage. Let's next assume that you need to grow your bank 6 months later, and you want 4800Wh of capacity, so you go and buy 3 more batteries. You now have four 12V batteries for a 12V system and your batteries must be wired in parallel making a 4-string bank (See Figure 4). And remember, more than 3 strings are not good (for flooded or sealed batt types).

Let's go back in time ... You initially buy two 6V batteries, each rated at 370Ah, instead of the single 12V battery at 100Ah. Each 6V battery has 2220Wh (6V x 370Ah) of capacity for a 4400Wh (2 batteries x 2200Wh) bank, consisting of two 6V batteries in one series string (See Figure 5).

Thus, an original purchase of two 6V, 370Ah batteries is almost the same in watt-hours as four 12V, 100Ah batteries (4400Wh versus 4800Wh). The upfront costs, though, are why most DIYers buy incrementally, but doing so is usually not advantageous in the long run. A typical 6V, 370Ah battery costs about \$245 - \$300, or \$490 - \$600 for two. Four 12V, 100Ah batteries usually cost about \$100 each, or about \$400 compared to \$490 - \$600.

Bottom line ... Plan ahead and buy today what you need for tomorrow to avoid getting in to a high string count battery bank.

### Amp-hour Capacity

A battery bank's total amp-hour (Ah) capacity equals the amp-hour sum of the strings. In Figure 4, each battery has a 20-hr rating of 100Ah. In a parallel circuit, voltage stays the same and current adds. So, for the bank in Figure 4, we have four 12V strings at 100Ah each string. Therefore, Figure 4 shows a 12V bank with an amp-hour capacity of 400Ah (4 strings x 100Ah).

In a series circuit, current stays the same, and voltage adds. Looking at Figure 5, we have two 6V batteries in series which creates a 12V bank. Each battery is rated at 370Ah; since the two batteries are in series, the current stays the same, therefore Figure 5 shows a 370Ah bank at 12V.

*SERIES – Positive to Negative*

*PARALLEL – Positive to Positive; Negative to Negative*

### Let's check the math ....

**Figure 4:** 4 strings at 12V at 100Ah.  $4 \times 12 \times 100 = 4800\text{Wh}$ .

**Figure 5:** 1 string at 12V at 370Ah.  $1 \times 12 \times 370 = 4440\text{Wh}$ .

## WIRING THE BATTERY BANK

Batteries can be wired in series, parallel, or both, depending on the desired bank's nominal voltage and the voltage of each individual battery.

The battery-based inverter determines the gauge of wire to use to interconnect the batteries into a bank. For example, if you have a 4800W inverter in 24V that draws at max power 200A, the proper gauge wire to safely carry 200A ( $4800w / 24v$ ) is #2/0 AWG (Ampacity charts show this 200A application can be up to 25', but ideally keep the inverter cables to 10' or less). Therefore, use #2/0 AWG cable between the inverter and the primary posts, and use #2/0 AWG to interconnect the batteries together to create the bank. Ensure the wire lengths are the same for balanced resistance amongst the batteries and the strings.

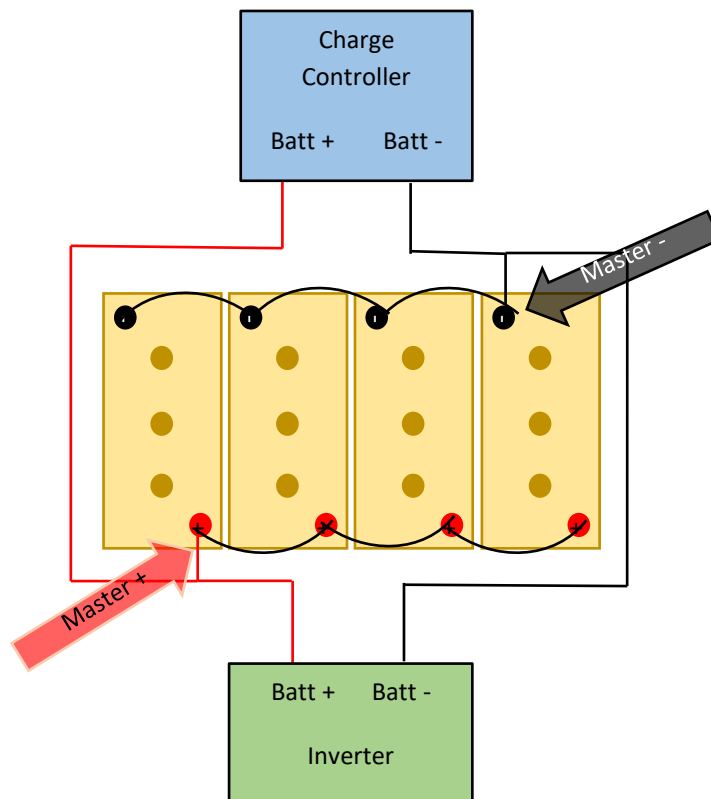

Figure 6

*Doubling the amps without changing the wire size increases the amount of heat by FOUR times!!*

## “Master” Terminals

“Master” terminal means the primary connection point on the bank for the positive cable and the negative cable to the inverter and charge controller (and any other direct-connect DC load). See Figures 6 and 7.

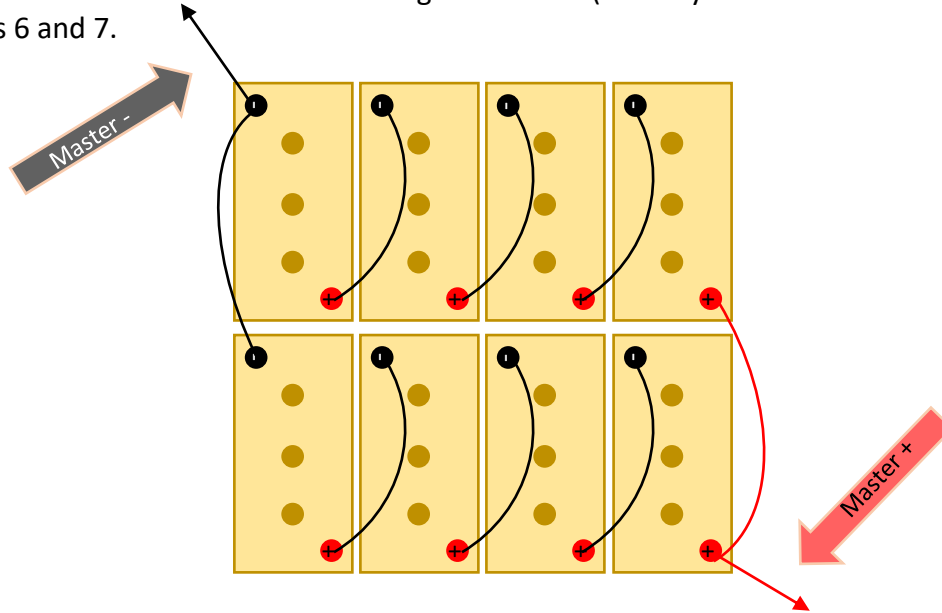

Figure 7

*Conductors carry a specific temperature rating based on the type of insulation used on the conductor.*



# DIY Manual



## WIRING & CIRCUIT PROTECTION

Wires are used as conductors of electric current. Insulators are material specifically designed not to conduct electricity. When current (amps) flow through the wire, a certain amount of heat is created due to friction caused by the wire's natural resistance. The greater the amps flowing through the wire, the greater the heat. Using an undersized wire to carry excess amps leads to excessive heat, which leads to a breakdown of the insulation, which leads to failure of the wire in terms of a short circuit or potentially a fire!

Circuit breakers are used to protect the wire in which the breaker is installed, not necessarily the equipment or electronics at the end of the wire. If you use a #10 AWG wire to carry 30A of current, then you need a 30A breaker. When 31 A (+/-) flows through the 30A breaker, the breaker trips, thus protecting the wire from insulation breakdown. ALWAYS USE APPROPRIATE CIRCUIT BREAKER PROTECTION!

Wire ampacity refers to the safe current carrying capacity of a wire. The National Electrical Code (NEC) publishes charts showing wire ampacity limits. Refer to such a chart when selecting your wire size. Selecting and installing the proper gauge wire ensures safety and system efficiency. Know your system and its current draw, and always use the right size wire and the appropriately rated circuit protection.

### WIRE SIZE AND GAUGE

Wire size is called gauge and is often referenced to the American Wire Gauge (AWG) standard, such as a #10 AWG wire. The higher the wire gauge number, the smaller in physical size is the wire. For example, an #18 AWG wire is smaller in physical size than a #10 AWG wire.

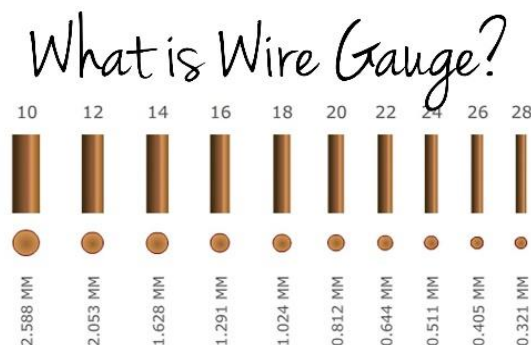



# DIY Manual

Factors which determine the appropriate wire gauge:

1. The anticipated current draw of a load or circuit;
2. The temperature to which the wire is subjected, influenced by
  - a. Ambient temperature,
  - b. If conductor conduit is exposed to direct sunlight,
  - c. Type of wire insulator, and
  - d. Equipment termination temperature rating;
3. Wire rating in terms of voltage and temperature;
4. Derating of wire based on conduit fill (Number of wires in the conduit); and
5. Ambient temperature correction factors.

**NOTE:** Refer to the NEC for more information on determining the correct wire gauge for your specific application. Special rules apply such as 4 or more conductors in the same conduit or conduit mounted on a rooftop as opposed to conduit mounted on the side of a building, away from direct sunlight. Refer to NEC Table 310.15(B)(16).

## Examples

- Disregarding (for simplicity) the possible correction factors mentioned above, determine the correct wire gauge needed to connect a 4000W inverter to a 24V battery bank, located 8 feet apart.
  1.  $4000W / 24V = 166A$ ,
  2. Reference Figure 6, and
  3. #2/0 AWG wire is required (180A at 8').
- Determine the correct wire gauge for a 4000W inverter with input power range of 22-24V with an efficiency rating of 85%, 8 feet apart.
  1.  $4000W / 22V / 0.85 = 214A$ ,
  2. Reference Figure 6, and
  3. #2/0 AWG wire is still correct (200A at 8').

**NOTE:** In the two examples above, if we apply correction factors for conduit fill and temperature, the values of 166A from Example #1 and 214A from Example #2 will be reduced by the correction factors. This means either less current can safely pass through the selected wire **OR** you as the installer need to select a larger size (smaller gauge #) wire.

- Determine the correct wire gauge to connect a PV array to the charge controller, based on PV short-circuit current (Isc) of 9.2A and a distance from array to charge controller of 45 feet.
  1. Maximum PV circuit current:  $9.2A \times 125\% = 11.5A$ ,
  2. Conductor ampacity:  $11.5A \times 125\% = 14.4A$ ,



# DIY Manual

3. Reference Figure 6, and
4. #6 AWG wire is correct (Use 15A row, 40' to 50').

**\*\* NOTE:** The 125% multiplication factor is a means to derate the current-carrying capacity of the wire for safety reasons, as explained below. Either you decrease current by 80% **OR** you oversize wire by 125%.

U.S. Coast Guard regulation requires all ungrounded current carrying conductors (except the starting circuit) to be protected with a circuit breaker or a fuse.

CIRCUIT TYPE			CURRENT FLOW IN AMPS																	
10% VOLTAGE DROP	Non Critical	3% VOLTAGE DROP	Critical	5A	10A	15A	20A	25A	30A	40A	50A	60A	70A	80A	90A	100A	120A	150A	200A	
CIRCUIT LENGTH	0 to 20 ft	0 to 6 ft		16 AWG	10 AWG	14 AWG	14 AWG	12 AWG	10 AWG	8 AWG	6 AWG	6 AWG	6 AWG	4 AWG	4 AWG	4 AWG	2 AWG	1 AWG	2 0 AWG	
	30 ft	10 ft		14 AWG	10 AWG	12 AWG	12 AWG	10 AWG	8 AWG	6 AWG	6 AWG	4 AWG	4 AWG	4 AWG	2 AWG	2 AWG	2 AWG	1 AWG	0 AWG	2 0 AWG
	50 ft	15 ft		12 AWG	10 AWG	10 AWG	10 AWG	8 AWG	6 AWG	6 AWG	4 AWG	4 AWG	2 AWG	2 AWG	2 AWG	1 AWG	1 AWG	0 AWG	0 AWG	3 0 AWG
	65 ft	20 ft		10 AWG	10 AWG	8 AWG	8 AWG	6 AWG	6 AWG	4 AWG	4 AWG	2 AWG	2 AWG	1 AWG	1 AWG	1 AWG	0 AWG	0 AWG	2 0 AWG	3 0 AWG
	80 ft	25 ft		8 AWG	8 AWG	6 AWG	6 AWG	4 AWG	4 AWG	4 AWG	2 AWG	2 AWG	1 AWG	1 AWG	0 AWG	0 AWG	0 AWG	2 0 AWG	3 0 AWG	4 0 AWG
	100 ft	30 ft		6 AWG	6 AWG	4 AWG	4 AWG	4 AWG	4 AWG	2 AWG	2 AWG	1 AWG	1 AWG	0 AWG	0 AWG	0 AWG	0 AWG	2 0 AWG	3 0 AWG	4 0 AWG
	130 ft	40 ft		4 AWG	4 AWG	4 AWG	4 AWG	2 AWG	2 AWG	2 AWG	1 AWG	1 AWG	0 AWG	0 AWG	0 AWG	0 AWG	0 AWG	2 0 AWG	3 0 AWG	4 0 AWG
	165 ft	50 ft		2 AWG	2 AWG	2 AWG	2 AWG	1 AWG	1 AWG	1 AWG	0 AWG	0 AWG	0 AWG	0 AWG	0 AWG	0 AWG	0 AWG	2 0 AWG	3 0 AWG	4 0 AWG
	200 ft	60 ft		1 AWG	1 AWG	1 AWG	1 AWG	0 AWG	0 AWG	0 AWG	0 AWG	0 AWG	0 AWG	0 AWG	0 AWG	0 AWG	0 AWG	2 0 AWG	3 0 AWG	4 0 AWG
		70 ft		0 AWG	0 AWG	0 AWG	0 AWG	0 AWG	0 AWG	0 AWG	0 AWG	0 AWG	0 AWG	0 AWG	0 AWG	0 AWG	0 AWG	2 0 AWG	3 0 AWG	4 0 AWG
		80 ft		0 AWG	0 AWG	0 AWG	0 AWG	0 AWG	0 AWG	0 AWG	0 AWG	0 AWG	0 AWG	0 AWG	0 AWG	0 AWG	0 AWG	2 0 AWG	3 0 AWG	4 0 AWG
		90 ft		0 AWG	0 AWG	0 AWG	0 AWG	0 AWG	0 AWG	0 AWG	0 AWG	0 AWG	0 AWG	0 AWG	0 AWG	0 AWG	0 AWG	2 0 AWG	3 0 AWG	4 0 AWG
		100 ft		0 AWG	0 AWG	0 AWG	0 AWG	0 AWG	0 AWG	0 AWG	0 AWG	0 AWG	0 AWG	0 AWG	0 AWG	0 AWG	0 AWG	2 0 AWG	3 0 AWG	4 0 AWG
		110 ft		0 AWG	0 AWG	0 AWG	0 AWG	0 AWG	0 AWG	0 AWG	0 AWG	0 AWG	0 AWG	0 AWG	0 AWG	0 AWG	0 AWG	2 0 AWG	3 0 AWG	4 0 AWG
	120 ft		0 AWG	0 AWG	0 AWG	0 AWG	0 AWG	0 AWG	0 AWG	0 AWG	0 AWG	0 AWG	0 AWG	0 AWG	0 AWG	0 AWG	2 0 AWG	3 0 AWG	4 0 AWG	
	130 ft		0 AWG	0 AWG	0 AWG	0 AWG	0 AWG	0 AWG	0 AWG	0 AWG	0 AWG	0 AWG	0 AWG	0 AWG	0 AWG	0 AWG	2 0 AWG	3 0 AWG	4 0 AWG	

Although this process uses information from ABYC E-11 to recommend wire size and circuit protection, it may not cover all of the unique characteristics that may exist on a boat. If you have specific questions about your installation please consult an ABYC certified installer.  
 © Copyright 2010 Blue Sea Systems Inc. All rights reserved. Unauthorized copying or reproduction is a violation of applicable laws.

Figure 6

## What does this all mean?

1. Let's assume you have a solar panel with an Isc of 9.2A.
2. The 9.2A rating is determined under standard test conditions. In the real world, the panel can produce more than 9.2A due to sunlight intensity as affected by altitude, reflection due to snow or other obstructions, refraction through clouds, or even the dryness of the air.
3. So, the panel's Isc is increased by a correction (safety) factor of 125%, just in case:
  - i.  $9.2A \times 125\% = 11.5A$
4. Next, the wire that will carry this 9.2A – 11.5A of current needs to be able to handle this amount of current PLUS its own (safety) correction factor of 125%. This is called the ampacity of the wire.
  - i.  $(9.2A \times 125\%) \times 125\% = 11.5A \times 125\% = 14.4A$



## DIY Manual

- ii. In this example, for a PV module with an  $I_{sc}$  rating of 9.2A, you need to ensure the wire its connected to has an ampacity rating of at least 14.4A.
5. Lastly, to select the correct sized circuit breaker, follow these two rules:
  - i. If you use a MidNite circuit breaker, the second 125% factor does not apply because our breakers conduct 100% of the rated current continuously. Use a 12A breaker to protect the 11.5A of current flow.
  - ii. If you do not use a MidNite circuit breaker, then the second correction factor (125%) applies. You will therefore need a 15A breaker for the potential 14.4A of current.

### Voltage Drop Considerations

When selecting the proper gauge wire to run between the PV array and the charge controller, thought should be given to the inevitable voltage drop across that distance. Voltage drop means the loss of voltage due to wire resistance. To minimize voltage drop, a larger size wire is needed. As a rule, the PV industry strives for 2% or less voltage drop in system design. Voltage drop calculators are available online or use a DC wire chart with voltage drops annotated.

$$E \text{ (Volts)} = I \text{ (Current)} \times R \text{ (Resistance)}$$

*If resistance increases and current stays the same, then voltage must lower (drop).*

### How does voltage drop impact MPPT charge controllers?

Voc is the maximum voltage a PV module can produce under test conditions (can be higher in cold temps). The Vmp is the maximum power voltage the panel will produce during normal operation. Vmp is on average about 72-82% of Voc. So, what does this mean? Although you used Voc to determine how to wire the panels in series or parallel and being mindful of the charge controller's input voltage limits, the Vmp is the voltage the MPPT charge controller actually manipulates to make power. Therefore, the voltage drop impacts Vmp.

For your MPPT charge controller to work, it needs to have a Voc at least 133% higher than the highest battery charge voltage. So, if your system is designed with an input Voc that is close to the minimums of the 133%, then you probably cannot afford a large voltage drop, otherwise Voc will drop below the minimum required for the MPPT charge controller.

**NOTE:** To determine correct wire size to minimize the negative impact of voltage drop, use **Voc** in your calculations. No correction multiplier is required. Using Voc in the calculations increases system efficiency.





# DIY Manual

**Example** – PV system with Voc = 90V, 48V battery bank, 30A PV input that is 50’ from the charge controller.

1. If the highest battery charging voltage is 59.2V, for example, then the MPPT charge controller needs an input minimum of 78.7Voc (59.2V x 133%).
2. A 3% voltage drop with #2 AWG wire means an effective Voc of 87.3V.
3. A 10% voltage drop with #10 AWG wire means an effective Voc of 81V.
4. If the MPPT charge controller needs a minimum of 78.7V and the #10 AWG wire is giving you 81V, that does not leave much headroom for a decrease in sunlight (early morning/evening), which means a drop in Voc. If Voc falls below the minimum needed to charge the batteries, then your charge controller will go into a resting mode until Voc rises.

## CIRCUIT BREAKERS AND FUSES

### Mounting Options

MidNite circuit breakers are available in DIN rail or panel mount configurations; our fuseholders are available as DIN rail mount. Select the mounting option based on the enclosure you have or intend to purchase. Figure 7 shows a DIN rail mount circuit breaker and Figure 8 shows a panel mount circuit breaker.



Figure 7



Figure 8

### Polarity Sensitive

Our DIN rail mount breakers (MNEPV series) are polarity sensitive, which refers to the orientation of the breaker versus the flow of current. A correctly installed breaker will capture the DC arc when the breaker is opened under load. An incorrectly installed breaker will trip at the rated current, yet may suffer internal damage in the arc chute due to being incorrectly wired regarding polarity.

Referencing Figure 9, the wire terminal marked “++” is connected to the highest current source. So, between the PV array and the charge controller, ++ is electrically toward the array. Similarly, between the battery bank and the charge controller, ++ is electrically toward the bank.



**Figure 9**



**Figure 10**

Our panel mount breakers, the MNEDC series, are NOT polarity sensitive; you can wire either terminal without regard to current flow. Figure 10 shows the terminal lugs of an MNEDC breaker. With this type of connection, ensure you use terminal lugs or ring terminals crimped to the wire.

### Torquing Circuit Breaker Setscrews

Bare copper wire inserted into the setscrew terminal of a circuit breaker will loosen due to a reaction called cold flow, or creep, which is the tendency of a solid material to move slowly under the influence of mechanical stresses, such as the setscrew snugged up tight against the bare wire. This may happen within an hour of installation. Therefore, it is important to properly torque the set screws per the breaker specifications (found on our website). Professional installers will tell you to torque it 2-3 times! Good practice is to 1) Torque the setscrew; 2) Wiggle the wire; 3) Re-torque setscrew. Figure 11 shows the setscrew terminal of an MNEPVC circuit breaker.



**Figure 11**

### Sizing Breakers

The National Electrical Code states that an overcurrent protection device (circuit breaker or fuse) can be loaded to only 80% of its rating for continuous loads. Since 80% is the inverse of 125%, the multiplication factor of 125% is used when sizing a circuit breaker or fuse. This “80 derate” rule does not apply if the circuit breaker or fuse is rated at 100% continuous duty, such as the MidNite series of DC breakers.



## DIY Manual

MidNite breakers are rated for 100% continuous duty and may be opened under a load (that means with current flowing through the breaker). Although the fuseholders are rated at 100% continuous duty, the fuses are NOT. Therefore, the fuseholders CANNOT be opened under a load. Since MidNite fuses are not rated at 100% continuous duty, the fuse must be derated by 80%, or increased by 125%, when sizing for circuit overcurrent protection.

**Example** – Determine maximum current, conductor ampacity, and size the circuit overcurrent protection device (breaker or fuse) for a PV array with a short-circuit current ( $I_{sc}$ ) of 8.9A.

1. Maximum PV circuit current:  $8.9A \times 125\% = 11.13A$
2. Conductor ampacity:  $11.13A \times 125\% = 13.91A$
3. Circuit overcurrent protection:  $8.9A \times 125\% = 11.13A$

**NOTE:** If using a MidNite 100% continuous duty circuit breaker such as the MNEPV series of breakers, the “Maximum PV circuit current” calculation equals the required circuit breaker amp rating (i.e., a 12A breaker for the 11.13A calculation). If NOT using a MidNite breaker or if using a MidNite fuse, then multiply the max PV circuit current by 125% again (i.e., a 15A breaker for the 13.91A calculation).

### What does this all mean?

1. The maximum current from the PV array to the charge controller will be 11.13A or less.
2. The proper wire gauge to install will be able to handle 13.91A over the distance of the PV array to the charge controller.
3. The minimum amp rating of the 100% continuous duty circuit breaker is 11.13A, or a 12A circuit breaker.
4. The minimum amp rating of the non-continuous duty circuit breaker or fuse is 13.91A, or a 15A circuit breaker or fuse.

**NOTE:** It is acceptable to round up to the next size breaker or fuse. That is, this example calls for a 12A breaker; a 15A breaker is acceptable if a 12A breaker is unavailable.

Let’s go back to the prior example of the 4000W inverter, 24V bank with input of 22V-24V, with an efficiency rating of 85%. What is the correct circuit breaker size for this system?

1.  $4000W / 22V / 0.85 = 214A$ ,
2. MidNite makes a 175A or a 250A DC breaker,
3. Since the inverter can surge to 2-3X its rated continuous wattage, the 250A breaker is the right choice.
4. And considering the surge potential, increasing the inverter-to-battery bank wire size is a smart and safe idea. #3/0 or #4/0 AWG wire is best for this application.



# DIY Manual

## Circuit Breaker Voltage Ratings

MidNite circuit breakers are rated at 125V, 150V, 300V, and 600V. Our fuseholders are rated at 1000V and we offer two fuse options: 600V or 1000V (either can be used in the MN fuseholder).

**NOTE:** 600V fuses are available till current stock is depleted; thereafter, only the 1000V fuses will be available.

Figure 12 shows a 300V circuit breaker, which are two 150V breakers connected in series via a brass jumper. The other end of this 300V breaker will also have the -- and ++ terminals. Remember, the ++ electrically points toward the highest current source, which is usually the PV array for this type of breaker.



Figure 12

**NOTE:** Always check the torque on the brass jumper screws, do not assume they are tight.

## Ground Fault Protection

“Ground fault” means a current carrying conductor (either positive or negative) is in contact with earth ground. Referencing Figure 13, we see by the arrow a MidNite 63A GFP breaker. This is a double stacked breaker with a normal 150V, 63A breaker on the left and a 0.5A shunt-trip breaker on the right, wired at the top to the battery minus and at the bottom to earth ground. The shunt-trip breaker detects voltage between negative and ground; if a voltage is present, the shunt-trip will open causing the 63A breaker on the left to open, thus removing the positive PV connection between the PV array and the charge controller.

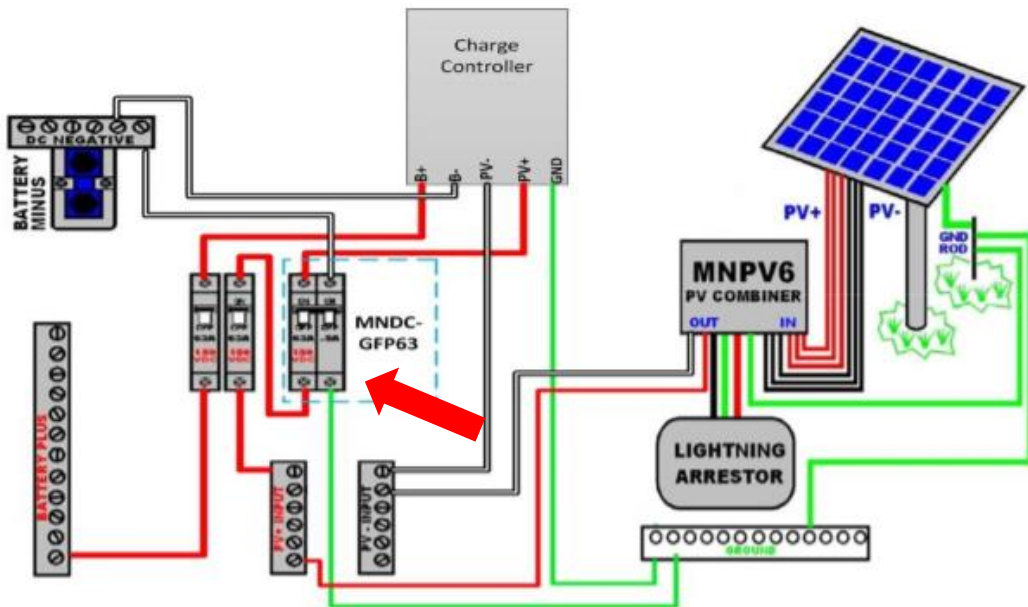

Figure 13

## Remote Trip Circuit Breaker

Figure 14 shows our 175A remote trip breaker, commonly used in rapid system shutdown applications, to secure DC inverter power. MidNite offers the RT breaker in 125A, 175A, and 250A versions. This breaker trips open when 19-24VDC is intentionally applied. The trip voltage is 1/10 of a second in duration; any longer in duration and the shunt trip coil burns out.



Figure 14



# DIY Manual



## CLASSIC CHARGE CONTROLLER

This chapter of the DIY Manual explains important characteristics of the Classic charge controller and presents insight and troubleshooting tips gleaned from thousands of Tech Support calls. Please read in junction with the Classic Owner's Manual for a complete understanding.

### CLASSIC EXPLAINED

#### Maximum Power Point Tracking (MPPT)

MPPT checks the output of the photovoltaic (PV) modules, compares that output to battery voltage, then fixes what is the best power the PV modules can produce and converts the PV output to the best voltage to get maximum current into the batteries. Maximum power varies with solar radiation, ambient temperature, and solar cell temperature, and is most effective during cold weather and cloudy days.

MPPT tracks and controls the Maximum Power Voltage, or  $V_{mp}$ , of the PV module(s). Whereas the Open Circuit Voltage,  $V_{oc}$ , is an important design consideration when determining how many PV modules to wire in a series string as PV input to an MPPT charge controller,  $V_{mp}$  is the voltage used to make power.  $V_{mp}$  is the voltage component, and  $I_{mp}$  is the current component, of the IV Power Curve. When you read about an MPPT charge controller "sweeping" the power curve, this means the controller is looking at the point on the power curve in which  $V_{mp}$  is maximum.

#### Voc and Vmp

On the back of a PV module is a factory sticker with performance specifications, to include  $V_{oc}$ ,  $I_{sc}$ ,  $V_{mp}$ , and  $I_{mp}$ .

**Voc** – Open Circuit Voltage: If the PV module is exposed to the sun, with both the positive and negative module wires disconnected,  $V_{oc}$  is the voltage you will measure with a multimeter.  $V_{oc}$  exists with daylight;  $V_{oc}$  is a function of light illuminating the PV module. When  $V_{oc}$  is maximum, current flow is zero, due to an infinite resistance in the circuit. This is shown by the power formula:  $P = V \times I$ .

$$P = V \times I$$



# DIY Manual

This reads as follows ... With constant power, if voltage rises, current drops. In this case, power is zero since current is zero:  $XVoc \times 0A = 0W$ .

**Isc** – Short Circuit Current: With a PV module NOT exposed to sunshine and the positive and negative wires connected to each other, with an ammeter you can measure Isc. When Isc is maximum, the voltage is zero, due to zero resistance in the circuit. This is shown by the power formula:  $P = V \times I$ .

$P = V \downarrow \times I \uparrow$

Similarly, power will be zero because voltage is now zero:  $0Voc \times XIsc = 0W$

**Vmp** – Maximum Power Voltage: This is the highest voltage on the IV Curve; that is, with current now flowing from the PV module, this will be the highest point of voltage.

**Imp** – Maximum Power Current: This is the current flow from the PV module at the Vmp point on the IV curve. In operation – when the Classic sweeps the IV curve and decides to lock on to a particular Vmp, then Imp is the current at this particular point of Vmp.

### So, what does all this Vmp and Voc stuff mean?!

With your Classic powered on, go to the 3<sup>rd</sup> Status page; you will see “Voc” in the lower left-hand corner of the MNGP screen. Voc is the voltage from the PV array as per how you wired the panels in series strings. In the upper left, you will see “IN.” IN is the array’s Vmp, which will constantly change as the Classic constantly sweeps the IV Curve. The Voc voltage needs to be at least 133% higher than the battery voltage at that moment in time for the Classic to work, otherwise the Classic goes to a resting mode. **Troubleshooting** – If your Classic goes to resting, check the Voc and the Vmp (“IN”). If Voc is zero, then you either have a disconnected wire from the PV array, reverse PV polarity at the Classic’s terminal block, or a bad Classic. If Voc is less than 133% of the battery voltage, then the Classic will not make power. Cloudy conditions will cause this to happen, or low light conditions (i.e., early morning or late at night).

### Classic Maximum Current Output

Each Classic model outputs a different amount of current based on the battery bank voltage.

CLASSIC	12V Battery Bank	24V Battery Bank	48V Battery Bank
Classic 150	96A	94A	86A
Classic 200	79A	78A	78A
Classic 250	61A	62A	55A



# DIY Manual

When designing a solar system, ensure you select the correct Classic controller to handle the maximum current. For example, say you plan to install 4000W of PV and you want to charge a 24V bank. Which Classic should you purchase? Answer –  $4000W / 24V = 166.7A$ . None of the Classics will support this system design. Too much current. You either use two controllers and split the 4000W into two separate PV arrays, or you change the battery bank voltage to 48V:  $4000W / 48V = 83A$ . In that case, the Classic 150 is the right model.

## Classic Charging Stages

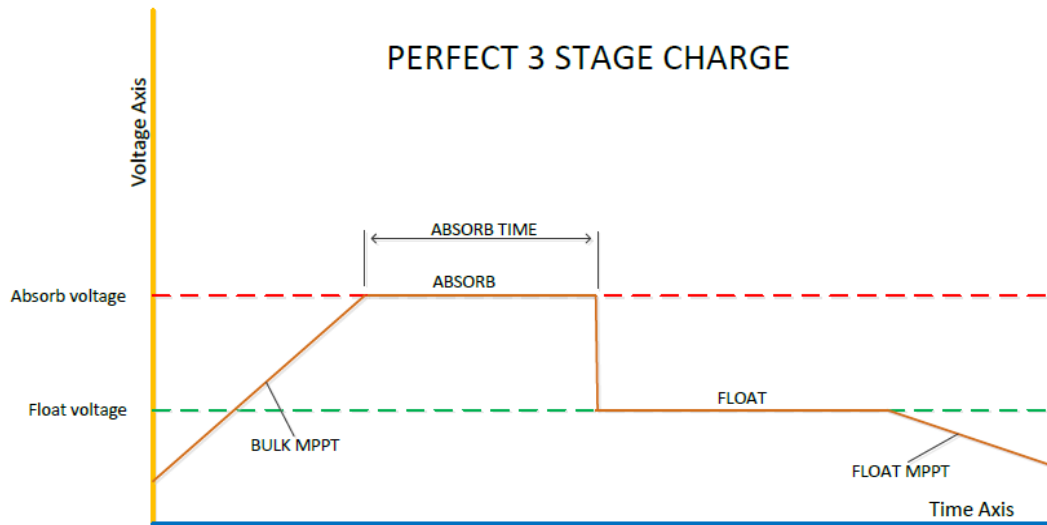

Figure 15

Figure 15 shows a perfect 3-stage charge if the sun were out and loads are small. The Classic wakes up on the left side in “BULK MPPT” and starts charging as hard as it can. It pushes the battery voltage up until it reaches the “ABSORB” voltage set point. The Classic regulates the battery voltage in Absorb by lowering the current and maintains the Absorb voltage for the amount of time set in the Absorb Time menu or until End Amps is reached. At this point the Classic transitions to “FLOAT” and maintains the Float voltage as long as there is sufficient power from the PV. When the power from the PV becomes too low, the battery voltage will drop below the Float voltage set point, the Classic will go into Float MPPT, and push as hard as it can to get back to the Float voltage.

Figure 16 shows two cycles in time where a large load came on (the dips). You can see the Classic came out of Absorb or Float and went into an MPPT mode. Anytime the Classic shows MPPT on its display it is doing the absolute most it can to produce power. If MPPT is not present that means the Classic is holding back and not putting out what it can to keep the voltage from rising above the set point.





# DIY Manual

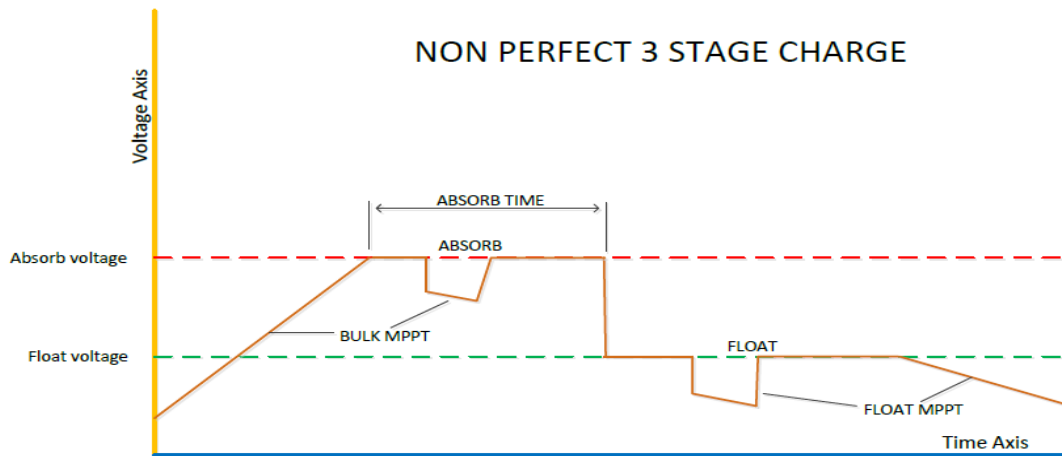

Figure 16

## Classic Charge Modes:

EQ MPPT - Full output trying to get to the Equalize setpoint.

EQUALIZE - Has reached the set point and is regulating to maintain voltage.

BULK MPPT - Full output trying to get to the Absorb setpoint.

ABSORB - Has reached the set point and is regulating to maintain voltage.

FLOAT MPPT - Full output trying to get to the Float setpoint.

FLOAT - Has reached the set point and is regulating to maintain voltage.

## Classic and Float - 4 ways to make the Classic come out of Float:

1. Start of a new day, which the Classic does at 23:59 hours. Ensure the clock is set correctly, or the Classic may start a new day at some random time.
2. A REBULK voltage setting will force the Classic back into Bulk mode if the battery voltage is  $\leq$  the REBULK setting for 90 seconds. Any "blip" or jump of the battery voltage above the REBULK setting will start the timer back at 90 seconds.
3. Power off the Classic for 30 seconds, then turn it back on. It will act like it does at sunup.
4. Forcing the Classic into Float using the "FLT" setting in the TWEAKS menu.

## MISC

### Charge Time

For the Absorb timer, use the formula  $\text{Charge Time} = 0.42 \times (\text{Bank Ah} / \text{Charge rate})$ . For example:

1. Your battery bank total amp-hour capacity is 400Ah
2. Your charge controller outputs 65A (This is based on PV wattage / nominal bank voltage)



# DIY Manual

3. Charge Time =  $0.42 \times (400 \text{ Ah} / 65\text{A}) = 0.42 \times 6.15 \text{ hours} = 2.6 \text{ hours}$ .

For the EQ timer, refer to your battery manufacturer specifications.

## T-Comp

There is only one setting in the Classic that can influence a different voltage than what you programmed (i.e., Absorb, Float, or EQ) and that is temperature compensation. You can check what the Classic thinks it is supposed to be charging to at that moment by going to the Charge menu and then into the T-Comp sub-menu and pressing the right soft key labeled "View."

As a battery gets colder than 25 degrees Celsius, the temperature needs to be elevated. As a battery gets warmer than 25C, the temperature needs to be lowered. You should check with your battery manufacturer and get the following three values:

1. Millivolts per degree C per cell to compensate (Default is -5mv). This setting is found in the Charge menu under T-Comp.
2. Reference temperature for the battery (Default is 25C). This setting is found by pushing status four times to get to the WBJr screen, then depressing the right soft key twice.
3. The maximum voltage to ever compensate to. This setting is found in Charge/Limits.

To do a sanity check, go to the Temp menu and write down the battery temperature, use that value in the formula below.

1. Temperature Offset = Number of cells x T-comp setting (Usually -5mv) x offset in degrees Celsius from the reference (Typically 25C).

### EXAMPLE:

- a. Assuming a 24V battery at 10C with a -5mV per cell offset.
  - b.  $12 \text{ (battery cells)} \times -0.005 \text{ (millivolts per degree C per cell)} = -0.06 \times -15 \text{ (Temp differential, } 10\text{C} - 25\text{C} = -15\text{C)} = 900\text{mV}$  or 0.9v above the set point.
  - c. For example, if your Absorb charge voltage was set to 14.8V, then in this scenario the batteries during Absorb will charge to 15.7V (14.8 + 0.9V).
2. If the battery was warmer than 25C, you would subtract the final value from the set point.

### EXAMPLE:

- a. Assuming a 24V battery at 35C (or 10C higher than temp reference of 25C).
- b.  $12 \text{ (battery cells)} \times -0.005 \text{ (millivolts per degree C per cell)} = -0.06 \times 10 \text{ (Temp differential, } 35\text{C} - 25\text{C} = 10\text{C)} = -600\text{mV}$  or -0.6v below the set point.
- c. For example, if your Absorb charge voltage was set to 14.8V, then in this scenario the batteries during Absorb will charge to 14.2V (14.8 – 0.6V).



# DIY Manual

*12V battery = 6 cells; 24V battery = 12 cells; 36V battery = 18 cells; 48V battery = 24 cells*

## EQ (Equalization)

EQ is a maintenance mode to equalize flooded lead-acid batteries, and some sealed batteries (Check with battery manufacturer if you have AGM or GEL batteries). EQ is a high voltage setting which basically boils the battery's electrolyte solution, to remove sulfates that are attached to the battery's lead plates.

### *EQ Dos & Don'ts*

- *Ensure electrolyte solution is full before EQ.*
- *Check electrolyte solution after EQ.*
- *During EQ, your inverter may alarm with an over-voltage condition.*

## Advanced

Ending Amps – Used in conjunction with the MidNite Whiz Bang Jr current-sensing device. Ending amps is set by the battery manufacturer and means the point at which the battery bank is full. During the Absorb charge cycle, the charge controller holds the voltage at the preset charge level, say 14.8V. As the batteries fill up, the current into the batteries decreases. When the decreasing current reaches the preset End Amps point, the charge controller stops the Absorb cycle and transitions to Float. In the absence of specifications from your battery manufacturer, you can use 1 – 3% of the total bank amp-hour capacity for the ending amps.

Re-bulk – Forces Classic back in to the Bulk charge cycle. Helpful if your inverter runs during the day, bank gets depleted, and enough sunlight hours remain to recharge the battery bank. Good re-bulk setting is your bank's 50% DOD voltage point (12.1V; 24.2V; or 48.4V). Or you can just let the Classic stay in Float, and the Classic will sense the current outflow and change to Float MPPT.

Re-bulk is useful for Lithium batteries as a “stop charge” mechanism.

### EXAMPLE:

1. You want the Classic to charge when the battery's voltage is less than 51.9V and rest when at 52V.
  - a. Set Absorb volts = 52V
  - b. Set Absorb time = 3 minutes.



## DIY Manual

- c. Set Float volts = 40V
  - d. Set REBULK = (Voltage you want to start back charging, must be > 40 Volts < 52 Volts)
2. The Classic will report BATTERY OVER VOLTAGE and will stop charging (RESTING) until re-bulk voltage is reached.

Skip Days – This setting forces the Classic in to Float at the start of the charging day vice in to Bulk. Useful if you have an unattended system, say at a remote cabin, one that you do not frequent often, and you do not need the solar system charging fully every day.

### Limits

Output Amps – This setting limits the Classic's output amps. Useful if your system produces more current than your battery manufacturer recommends. Also useful if you installed a circuit breaker between the Classic and the battery bank that is too small for the current load, and you want to stop nuisance tripping of the breaker. Say your system outputs 80A yet you installed a 63A breaker and it keeps tripping. Change the Output Amps to 63A until you can replace the breaker with the correct size.

Input Amps – Limits the incoming amps from the PV array. Usually not needed.

### Max and Min T-Comp Vs

1. MAX - Leave at default. Only change if cold battery offset increases voltage to where inverter shuts down from HI BATT. If so, cap it so inverter stays on.
2. MIN – Leave at default. If the battery is hot enough to make it drop too low, there will be bigger issues to deal with.

### Mode Menu

Solar – Default mode for most all solar systems. Classic sweeps the IV Curve in 0.5 seconds or less and will re-sweep at a user-adjustable interval (Mode/Solar/Setup), normally every 3 minutes or sooner if the Classic determines a new sweep is necessary.

Wind Track – Used with wind turbine operations. Select a preprogrammed wind curve or create your own. The wind curve consists of 16 steps along the curve, defined in terms of a voltage and a current at each step. Best to start the curve at 2V higher than your nominal battery bank voltage. For example, with a 24V bank, Step 1 of the curve will have a voltage setting of 26V and 0A.

Hydro – Used with a micro hydro system or other varying voltage DC inputs. Hydro mode has two user-selectable settings: Sweep interval in minutes and Sweep Depth in %.



# DIY Manual

***DO NOT connect an engine-driven DC generator to the Classic! These will almost always be a constant voltage DC source, which will cause harm to the Classic and void the***

Legacy P&O (Perturb and Observe) – To “perturb” means to change. In this mode, the Classic will intentionally change or move away from the first found  $V_{mp}$ , measure the reduction or increase in power out, then sweep again to lock on to either a higher or lower  $V_{mp}$  (relative to the first found  $V_{mp}$ ), always seeking the best  $V_{mp}$  for maximum power production. Legacy P&O has a slower sweep and is useful when mismatched PV is installed, which means two different  $V_{mp}$  points. User-selectable set points include the interval between sweeps in minutes and the sweep depth as a % of change in watts.

Dynamic – Similar to Solar Mode, tracks change in power on the fly. Dynamic MPPT uses the voltage dip on the solar panel multiplied by the increasing current every switching cycle to determine the error signal that will be produced to regulate the duty cycle. The dynamic response detects the slope of the IV curve, creating a power ramp from which the error signal intersects creating a power representative duty cycle.

U-Set Voc – Manual mode based on a percentage of Voc. The Classic will sweep based on the user-set time in minutes and then lock on to the voltage as determined by the pre-set. Useful for testing or different hydro or DC inputs.

***Mode must be manually turned ON after changing the mode.***

## TROUBLESHOOTING

### **Classic Makes No Power: Resting**

Does your MNGP show the Classic is Resting? Resting means the Classic is not in Bulk, Absorb, Float, or Equalization charging modes; basically, the Classic is waiting to be called upon to make power. If the PV input is absent or the PV voltage is too low, the Classic will remain in Resting.

Check that the Mode is ON. Go to the Mode menu and make sure it is in Solar and ON. If not, set both and press Enter to save. If the Mode is OFF, the MNGP will display “Mode is OFF” vice “RESTING,” but the Classic will act like it is resting.

Check the Reason for Resting. From the 1<sup>st</sup> Status page, hold the left arrow and tap Enter. The number between IN and BATT, top center, is the Reason for Resting code. After performing the troubleshooting suggestions below with no success, call MidNite’s Tech Support with that RFR code for further assistance.

Change the Mode to Legacy P&O to see if this brings the Classic out of Resting.



# DIY Manual

Is it overcast outside? Panels need sunlight intensity (photons) to create PV current. No current = Resting.

## PV Input Issue

If the PV input voltage drops too low or is absent, the problem probably lies in the PV source circuit; that is, the wiring, disconnects, and circuit breaker(s) on the PV side of the charge controller.

**NOTE:** A poor connection in the PV source circuit may generate a higher resistance, which leads to heat build-up, which reduces or “drops” the voltage, which increases the current flow. All of this is bad! Check your connections.

### Reasons for low or no PV voltage:

1. Defective PV module:
  - a. Bad internal solder joint between cells,
  - b. Defective internal bypass diodes, or
  - c. Defective module PV connectors.
2. Defective installation of PV connectors:
  - a. Poor crimping of the terminal, or
  - b. PV connector not plugged in all the way.
3. A wire shorting out intermittently:
  - a. Pinched wire that might be shorting out when the aluminum module frame expands and contracts, or
  - b. A wire that has been moving with the wind and rubbed through the insulation.
4. PV input circuit breaker:
  - a. Loose wire connection into the PV input circuit breaker,
  - b. Using a circuit breaker NOT rated for DC current,
  - c. Defective components inside the circuit breaker, or
  - d. Loose crimp/screw/lug of the wire connected to the circuit breaker.

*Connecting or disconnecting PV connectors while the module is in the sun MAY damage the connector contacts.*

## Low PV Voltage

As explained earlier, the Classic needs the PV Voc input to be at least 133% higher than the battery voltage to perform MPPT operations. If the Voc is lower than that, the Classic will rest.

How are your panels wired? If all the panels in your array are wired in parallel, the Classic sees the voltage of a single panel. In a parallel configuration with a 24V or 48V battery bank, more than likely your Voc is too low and the Classic will rest. **Solution** – Wire the panels in series, but not to exceed the Classic’s voltage input limits: 150V for the CL150, 200V for the CL200, and 250V for the CL250.



## DIY Manual

Is the IN voltage 0 on the MNGP? If so check for reverse polarity on the PV input to the Classic.

### Battery Over-voltage

Ensure the Battery voltage is below the Absorb and Float voltage setpoints. If not, do you have another charging source (2<sup>nd</sup> solar, wind, inverter-charger, or generator) on your battery bank? If so, turn it off until you finish troubleshooting the Classic.

Go to the 6<sup>th</sup> Status page; you will read CLASSIC XXX (i.e., CLASSIC 150) at the top left of the MNGP display. In the upper right corner, you will see XXV BAT (i.e., 12V BAT). Is this voltage correct for your battery bank? If not, perform a soft factory reset (VMM, instructions in this Manual).

During initial Classic set-up, one of the steps is to recognize the battery bank nominal voltage (i.e., 12V, 24V, 48V). If you accepted the wrong bank voltage and set the charge voltages, the Classic will show an over-voltage condition. For example, if you accepted the bank voltage as 12V then programmed in the Absorb charge voltage at 29.6V, you will get an OV condition.

### Disappearing PV IN Voltage

Disconnect the PV wires from the Classic's input terminal block. Using a multimeter, measure the PV voltage directly from the PV wires. Is voltage present? If not, see PV INPUT ISSUE section above. If voltage is present, reconnect the PV wires to the Classic's terminal block. Be mindful of polarity and always turn off circuit breakers before connecting or disconnecting any wires. With the PV wires connected, does the IN voltage drop to zero or near zero volts? If so, the Classic is defective. Call MidNite's Tech Support for further assistance.

### Classic Makes No Power: Bulk-to-Resting

Does your MNGP show the Classic switching between Bulk and Resting? This means the Classic is trying to make power, has sufficient PV input voltage, goes in to the Bulk charging mode, then very quickly switches to Resting. You may hear an internal relay click.

1. If PV IN voltage drops to battery voltage or close to it, the problem is probably a bad PV connection.
2. If PV IN voltage remains the same or at a normal level, the Classic has probably lost its FET drive.
3. If the PV IN voltage is normal and the Classic stays in Bulk or shows Bulk-to-Resting yet makes no power, you may have a bad resistor - R145. Repair of unit at our factory is required.

**NOTE:** With the PV wires disconnected from the Classic or the PV input circuit breaker turned off, does the MNGP show some IN voltage? If yes, this is a good thing. The Classic has a 10K ohm resistor across the BATT POS and PV POS terminals. This resistor pre-charges the PV input capacitors up to about 2/3rd battery voltage, which is the IN voltage you are seeing. If you see 0V, that is a bad thing. The Classic needs repair.



# DIY Manual

## Classic Will Not Turn On

1. Check Classic-to-battery circuit breaker.
2. Check for reverse polarity of battery positive and negative connections to the Classic.
3. Battery voltage needs to be 10V or higher for the Classic to power up. If less than 10V, charge the battery bank using an external source of power.

## Classic Stuck Sending Data

1. Check the MNGP firmware (FW) version. The MNGP's firmware must "match" the Classic's firmware (i.e., 2133 MNGP matches 2126 Classic). Call MidNite's Tech Support for matching firmware versions.
2. If you have multiple Classics, did you accidentally switch front panels amongst the Classics? If so, you may have introduced mis-matched FW versions.
3. You may have a bad processor or weak solder joints in the Classic. To test the processor:
  - a. Disconnect MNGP cable from Classic
  - b. Power down Classic for 30 seconds.
  - c. Power up Classic without MNGP connected.
  - d. Does the Classic POST (Power On Self-Test – lights illuminate, fans turn on)?
    - i. Yes – Bad firmware.
    - ii. No – Bad processor.

## Ground Fault

Ground Fault means one of the current-carrying conductors (positive or negative) is in contact with earth ground. The Classic has a built-in ground fault protection (GFP) circuit that detects current flowing from ground to the battery negative through the Classic.

If a ground fault is detected, the Classic will cease power production and alarm. The GF condition must be fixed and the Classic power-cycled off then on to clear the alarm.

To test the Classic's GFP feature – Connect a 5A circuit breaker between Battery + and earth ground. Turning this on simulates a GF and will trip the Classic.

## Arc Fault

An arc fault is a short which produces an electrical spark (arc). An arc fault may occur on the PV source circuit or even on the battery side of the Classic.

To test the Classic's AF feature – In the combiner box, loosen one of the PV strings at the busbar, and slowly remove it to make an arc. The Classic will report an arc fault and cease making power. To reinstall – turn off that string's PV circuit breaker; reattach the PV wire and torque as needed; power cycle the Classic off then on.





# DIY Manual

## To reduce AF nuisance tripping:

1. Adjust AF time and sensitivity as per the Classic Owner's Manual. Power cycle the Classic off then on for these settings to take effect.
2. Consider re-wiring the Classic battery output closer to the batteries. In other words, if the Classic B+ is connected to a battery positive busbar, remove that connection and run the conductor directly to the battery via a circuit breaker. **Reason** - This is the point at which any ripple from the AC loads can work back into the DC side of the Classic. And heavy AC loads and/ or overly long inverter battery cables can make this situation worse.

## Follow-Me

The Classic's Follow-Me network shares charge mode coordination, ground fault detection/shutdown, and battery temperature sensor (BTS) sharing. No settings are shared amongst the Classics, such as Whiz Bang Jr info (SOC%) or AUX controls.

Wire the BTS and Whiz Bang Jr to the first Classic in the series. The first Classic shares battery temperature data with all Classics. The Whiz Bang Jr, referencing the End Amps setting, informs the first Classic that the batteries are full, in turn that Classic terminates the Absorb charge cycle and transitions to Float. Via Follow-Me, the first Classic tells the other Classics to go to Float.

## Follow-Me Troubleshooting

1. Ensure all Classics have the same firmware versions.
2. Turn on Follow-Me in the Tweaks Menu.
3. The Follow-Me indicator is a blue LED located internally on the control circuit board, toward the top half of the Classic, seen through the front cover vent.
  - a. Is the blue LED blinking slow (1 second) or fast (1/10 second)?
    - i. Slow = bad; fast = good.
4. Check the Follow-Me cables.
  - a. Ensure you have cross-over cables (Pin 1 goes to Pin 4 on the other end if using RJ-11 cables, or to Pin 6 if using RJ-12 cables).
  - b. Unplug all Follow-Me cables.
  - c. Go to Classic #1, observe the blue LED inside at the top, slow 1 second blink? Good.
  - d. Loop one of the cables from the middle jack to the bottom jack of that Classic.
  - e. Observe the blue LED going from 1 second to 1/10th of a second blink.
  - f. If so, cable is good, Classic is good.
  - g. If the blink is long in duration, that means the cable is bad.
  - h. Test all cables in the same manner.
5. Factory reset all the Classics and re-enter all the values.



# DIY Manual

## Got Comm?

1. Boot Jumper installed – This causes the Classic to halt the boot-up process and the MNGP displays GOT COMM?
2. Classic MNGP Port - Can use either the top or middle jacks. If using the middle jack – no updates and will lose green and yellow MNGP LEDs.

## MNGP Reset

1. Under MISC/MNGP/EXTRAS, type in 1-4-2 and pick YES.
2. If you enter the password in MNGP, that resets the MNGP.
3. If you enable password in Tweaks, that password-protects the entire Classic (same PW used, 1-4-2).

## MNGP Cable Info

1. Limited to about 15 ft due to the 9V power supply.
2. Best to use a 6-pin, RJ12 cable.
3. An RJ11, 4-wire cable will work, but you will lose the green and yellow LEDs on the left of the display.
  - a. Green if turned on = FLOAT
  - b. Yellow if turned on = Current Limit

## Over-Current Protection protects the Classic from damage. Reasons for OCP activation:

1. Bad inductor inside the Classic. (Repair needed)
2. Bad or weak battery; bad or faulty wire connection. (Corrosion / high resistance / loose)
3. Classic sharing the inverter battery cables. (Classic connected to battery bus bars near the inverter)
4. Cables and/or wires for the inverter or Classic are too small. This can cause surges in the inverter to attempt to pull more current from the Classic than it can provide.
5. If OCP does not activate fast enough, transistors in the Classic will be damaged. (Repair needed)

## Factory Reset

**Soft** - Resets all settings to factory defaults; VMM (Vulcan Mind Meld, for 2-finger application)

1. Write down any custom settings for reference prior to resetting the Classic.
2. Turn the battery and solar power to the Classic off.
3. Depress both Left and Right arrows.
4. Turn the battery power back on.
5. Hold the arrows until the first screen pops up (Charging Source: Solar, Wind, Hydro).



## DIY Manual

6. Follow the on-screen prompts to complete the setup.

### Hard - Hardware factory restore

1. Turn the PV and battery power off to the Classic.
2. Remove the front cover.

**NOTE:** There are 3-4 sets of jumpers directly above the blue terminal block. For our purpose here, we will call the left most jumper “JP1” and the right most “JP4” (actually labeled "Boot").

3. Locate the 2 jumpers JP1 and JP4. Remove the jumpers and hold in your hand.
4. Turn the battery power on to the Classic.
5. Within 1 minute, place jumper JP4 on its two pins (vertical orientation), then place jumper JP1 on its two pins. At this point the 3 LEDs on the top of the circuit board should flash back and forth for between 60 and 120 seconds.
6. After the flashing stops, power down the Classic and remove JP1 and JP4; stow them back on a single pin.
7. Put the front cover on.
8. Power up the Classic.

***ALWAYS** turn the battery power on first to the Classic, then the PV input.*

### WHIZ BANG JR. (WBJr)

The MidNite Whiz Bang Jr is a current-sensing device that accurately measures all current into and out of your battery bank. The WBJr calculates a precise battery bank State of Charge (SOC) and Ending Amps to transition from the Absorb charge state to Float. In this section, we will discuss how to 1) wire up the WBJr and 2) program the Classic and KID charge controllers to work with the WBJr.

The WBJr is mounted on the side of a shunt. The shunt is wired in series on the electric low side, or negative side, of your system. See Figure 17 below. The wire marked “Cable to Inverter Negative” shows the shunt connection point for **ALL** negative wires from charge controllers, inverter, wind turbine negative, and even a battery charger running off a generator. All negatives land there. The other shunt bolt connection is the single cable from the shunt to the battery bank’s master negative terminal.

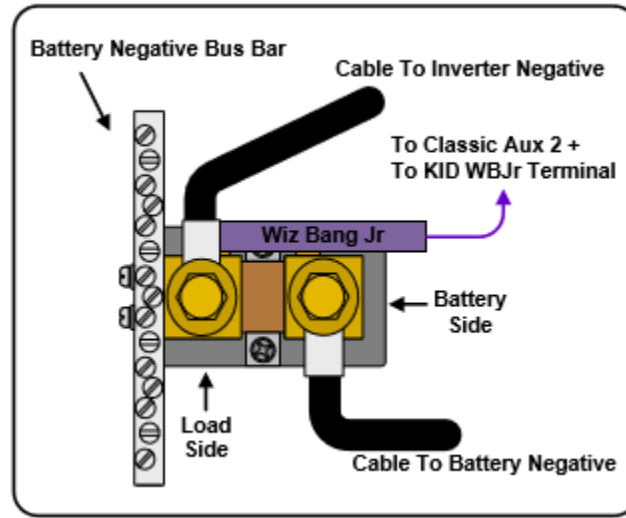

**Figure 17**

Notice the orientation of the WBJr purple wire relative to the shunt – the purple wire points toward the battery bank. Very important for the WBJr to be mounted this way; if mounted backwards, your current readings will be inverted.

## Classic Charge Controller Settings

### Whiz Bang Jr Status Page

1. Depress Right Soft Key (upper right button)
2. Enter the following data:
  - a. Battery bank amp-hour capacity
  - b. Battery Efficiency
3. Depress Right Soft Key again
4. Enter the following data:
  - a. Battery temperature reference
  - b. Leave the change % at 0.0% unless in winter time when your bank will lose capacity. Adjust by 0.5% at a time. This brings the SOC into line with available capacity. It is trial and error. Basically you will match SOC versus bank voltage (i.e., 50% SOC equals 12.1V for a 12V bank).
5. Depress Enter button to save changes.

### AUX Menu

1. Depress right arrow, highlight the Aux 2 column
2. Depress Right Soft Key (reads "Setup" on MNGP)
3. Scroll up/down using arrow keys to highlight WHIZBANG JUNIOR
4. Depress Enter button to save changes



# DIY Manual

5. Depress Main Menu button to return to previous AUX Menu page
6. Use up/down arrows to ensure WIZBANG JUNIOR reads below the header AUX 2
7. Depress Enter button to save changes

## Charge Menu

1. Using arrow buttons, highlight Advanced sub-menu, depress Enter button
2. Set Ending Amps based on bank's amp-hour capacity per battery manufacturer's guidance. Without guidance, 1% - 3% of total amp-hour capacity is common.
3. Depress Left Soft Key so that SHUNT reads below Ending Amps on MNGP.
4. Depress Enter button to save changes. Now the Classic will read current off the external shunt vice its internal shunt.

## KID Charge Controller Settings

### AUX Menu

1. Depress Menu Back button, then scroll to AUX, depress Enter button
2. Use up/down arrows till WBJR reads to the right of FUNC
3. Move asterisk to left side of AUTO
4. Depress Setup button
5. Enter battery bank amp-hour capacity, depress right arrow
6. Enter bank efficiency %, depress right arrow
7. Enter reference temp, depress right arrow
8. Enter capacity percent change per battery manufacturer, commonly 0.5% to 1.0%
9. Depress Save button

### TECH Menu

1. Depress Menu Back button, scroll to TECH, depress Enter button
2. With asterisk to the left of CALIBRATION, depress Enter button
3. Depress right arrow two times
4. Use up/down arrows till WBJR shows
5. Depress Save button

### BATTERY Menu

1. Depress Menu Back button, then scroll to BATTERY, depress Enter button
2. Use arrow buttons to move asterisk to left side of TCOMP, then depress right arrow
3. Move asterisk to left side of Advanced, depress Enter button
4. Set End Amps as recommended by battery manufacturer, commonly 1-3% of Ah capacity, 20-Hr rating.