

LITTLE SOB (SHUT OFF BOX) Installation and use guide

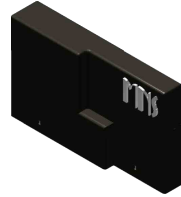

600V Receiver



AC
Transmitter



DC
Transmitter



1000V Receiver

MNLSOB System Overview

Rapid shutdown is a new requirement in NEC 2014 Article 690.12. This requires the PV system to be shut down to a safe voltage level in 30 seconds*. The MNLSOB system fulfills the requirements of NEC 2014 690.12 for string level shutdown and a module level installation fulfills NEC 2017 690.12. Inverters store energy in input capacitors. Some inverters may require the MNBLEEDER box (sold separately) to bring the system voltage down within the required time.

The MidNite Solar MNLSOB shutdown system is a convenient, economical way to help meet the requirements of NEC 690.12 and ensure safety for fire rescue and other emergency aid workers. The MNLSOB (Little Shut Off Box) is ready for today's requirement for string level shutdown and future requirements for module level shutdown.

Each Little SOB system consists of a transmitter and one or more receivers. A receiver may be connected to each solar panel in a string for module level shutdown or to the last module in a string for string level shutdown. Any module the receiver is attached to must not exceed 80V open circuit and (depending on receiver model) 600 or 1000 volts total string voltage. The transmitter, located at the PV+ entry of a grid tie inverter or charge controller, generates a signal that causes the receiver to connect each string or module to the charge controller or inverter. The receiver attenuates the modules or string in the event of loss of signal. The receiver is powered by the panel to which attached.

The LSOB is intended to attenuate the array as part of a rapid shutdown system and does not replace required disconnects. The LSOB does not initiate shutdown. Removing power to the transmitter either from the service disconnect or from a switch intended for this purpose will cause the LSOB to attenuate the array.

System Function

The transmitter generates a signal which is inductively coupled into the string PV+ line. The signal consists of an encoded 484.84 kHz tone. This signal is detected by the receiver and, if the received signal is correct, connects the string to the inverter or charge controller. This ensures that the receiver only responds to a valid signal. In the absence of a valid signal, the receiver shuts off. After a valid command to turn on is received, the string is connected to the inverter or charge controller. When the signal goes away, there is a delay of 5 seconds before the receiver shuts off.

MidNite Solar 17722 - 67th Ave N.E.
Arlington, Wa 98223 360.403.7207
www.midnitesolar.com



IMPORTANT SAFETY INSTRUCTIONS

SAVE THESE INSTRUCTIONS - THESE INSTRUCTIONS CONTAIN IMPORTANT SAFETY AND OPERATING INSTRUCTIONS FOR LSOB Rapid Attenuation models: MNL SOB-T1-600, MNL SOB-T1-AC, MNL SOB-R1-600, MNL SOB-1000.

If you do not fully understand any of the concepts, terminology, or hazards outlined in these instructions, please refer installation to a qualified dealer, electrician or installer. These instructions are not meant to be a complete explanation of a renewable energy system. All installations must comply with national and local electrical codes. Professional installation is recommended.

GENERAL PRECAUTIONS:

If service or repair should become necessary, contact MidNite Solar Inc. Improper servicing may result in a risk of shock, fire or explosion. To reduce these risks, disconnect all wiring before attempting any maintenance or cleaning. Turning off the inverter will not reduce these risks. Solar modules produce power when exposed to light. When it is not possible to disconnect the power coming from the Photovoltaics by an external means such as a combiner, cover the modules with an opaque material before servicing any connected equipment.

Do not work alone. Someone should be in the range of your voice or close enough to come to your aid when you work with or near electrical equipment. Remove rings, bracelets, necklaces, watches etc. when working with photovoltaic modules or other electrical equipment. Power from an illuminated photovoltaic array makes a very effective arc welder with dire consequences if one of the welded pieces is on your person.

Wiring methods used shall be in accordance with the Canadian Electrical Code, Part I.

Wiring must be done in accordance with the National Electrical Code Article 690 ANSI/NFPA 70. Use Class 1 wiring methods for field wiring connections to terminals of a Class 2 circuit. Use only 14-10 gauge AWM wire. Select the wire gauge used based on the protection provided by the circuit breakers/fuses. Overcurrent protection must be installed as part of the system installation. Refer to the wiring diagrams provided in this manual for breaker/fuse/GFDI sizes and model numbers.

Important: An external GFDI device is required in PV systems by Article 690 of the National Electrical Code for the installation location.

Use of attachments or accessories not approved by MidNite Solar could result in damage or injury.

Before making any connections verify that the circuit breakers are in the off position including the inverter breaker. Double check all wiring before applying power.

INSTRUCTIONS DE SÉCURITÉ IMPORTANTES

CONSERVER CES INSTRUCTIONS - CES INSTRUCTIONS CONTIENNENT DES INFORMATIONS IMPORTANTES POUR UTILISER LE LSOB ARRÊT RAPIDE DE CELLULES SOLAIRES DES MODÈLES MNLSOB-T1-600, MNLSOB-T1-AC, MNLSOB-R1-600, MNLSOB-1000. EN TOUTE SÉCURITÉ.

Avant l'utilisez cet appareil lis et comprends toutes les instructions et avertissements.

Si vous ne comprenez pas l'une des concepts ou des instructions contenu dans cette manuel consulter un agent spécialisé.

Si des réparations sont nécessaires contactez MidNite Solar pour plus des informations. Danger de choc électrique et de risque de brulure. Rien à dépanner à l'intérieure du cette appareil. Ne pas ouvrir le couver. Pour toute réparation ou service d'entretien, consulter un agent spécialisé. Il y'a peut-être plusieurs sources d'alimentation dans cette system. Débrancher toutes les interrupteurs avant toute d'entretien où nettoyage.

Ne travaillez pas seul. Quelqu'un devrait toujours être à proximité pour aider en cas d'une situation d'urgence.

Retirer bagues, bracelets, colliers, montres, et quelles choses comme ça. Il y'a risque des blessures graves s'il y'a un court-circuit. Cela pourrait ruiner votre journée entière.

Cette appareil n'avoir pas un détecteur des fautes de terre. C'est nécessaire de emploi la protection contre des fautes de terre a l'extérieure de cette appareil en conformité avec le National Electrical Code.

Les méthodes de câblage utilisés doivent être conformes au Code canadien de l'électricité, Partie I.

Le câblage doit être fait en conformité avec le National Electrical Code Article 690 ANSI / NFPA 70. Utiliser des méthodes de câblage de catégorie 1 pour les connexions de câblage sur .des terminaux d'un circuit de classe 2. Utilisez uniquement des fils de AWM de calibre 14-1/0. Sélectionnez le type de câble utilisé sur la base de la protection prévue par les disjoncteurs / fusibles.

Symbols used in this manual



Hazard Symbol
Hazardous condition may exist.
Caution required.



High Voltage Symbol
Hazardous potentially lethal
voltage

LITTLE SOB (SHUT OFF BOX) Installation and use guide

Mounting the receiver

The receiver is designed to mount on the rack near the panels that it is connected to but may be bolted to any appropriate nearby structure.

Refer to the rack manufacturer's instructions.

Use a 5/16 X 1" bolt for alternate mounting schemes.

Do not overtighten. MNL SOB receivers are fully potted and may be mounted where exposed to weather.

Example of typical rack mounting.

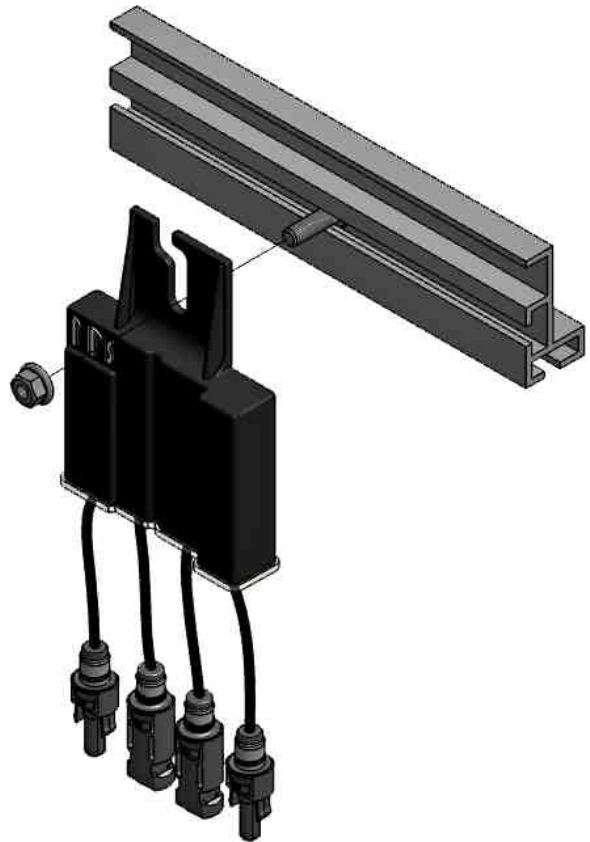

Mounting the transmitter

The transmitter may be installed in or near the inverter.

Important! The transmitter must be installed in a protected environment such as in the inverter or similar enclosure.

Do not allow transmitter wires to be exposed outside of an enclosure.



12 Volt transmitter:
Connect the red wire to +12 to 16 VDC and black wire to negative



AC Transmitter:
Connect black wires to 90-300 VAC 50-60 HZ



Transmitter output coil

The transmitter may also be mounted with double stick tape or hook and loop fastener (Not Supplied).



Example of customer supplied double stick tape / hook and loop fastener.



Example of PV in wires routed through the transmitter output coil
See page 6 for wiring instructions.

Introduction. **This document is for the installation and operation of the LSOB.**

Important! The Little SOB is **NOT** a service disconnect nor is it intended to be used as one. The transmitter stops sending a keep-alive signal to the receiver **ONLY** when power is removed from it. In the case of an AC powered transmitter, the AC power to the AC powered transmitter **MUST** be disconnected; a DC powered transmitter **MUST** have the DC that powers it disconnected. Power from the array will not be disconnected until this power is removed.

Connection and Use

For the basic installation, connect the LSOB system as shown in the wiring diagram on page 6. It is possible to connect the receiver in other positions (e.g; in the middle of the string or at the furthest panel). The LSOB may be used for string or module level shutdown. See Application Note 1.

Either the plus or minus string wire may go through the transmitter's output coil but not both plus and minus. This would cancel any signal preventing proper operation. See Application Note 1.

Only one transmitter is required per installation. Multiple strings can be controlled by a single transmitter by passing the PV+ wire of each string through the transmitter coupling ring. See Application Note 2.

Application Notes

Note 1

Since the transmitter signal is carried through the entire solar string, the receiver may be placed at any point in that string.

It may be more convenient to couple the transmitter using the PV- versus the PV+, depending upon the installation.

The LSOB may be used as a string (one receiver per string) or module (one receiver per panel) level shutdown. The transmitter can drive six strings.

Note 2

If more than one transmitter is used each transmitter must be on a separate system without interconnections to avoid interference to other transmitters. One transmitter can provide signal for several receivers on the same string or parallel strings. For example two inverters powered by two separate strings would require two transmitters while a single inverter even with many parallel strings would require only one transmitter.

To avoid nuisance tripping when multiple transmitters are used, the PV conductors connected to each transmitter should not share the same conduit or wiring enclosure.

Note 3

The transmitter has been tested with runs up to 2000 feet. The best performance will be achieved by avoiding odd multiples of 500 feet. The maximum run length depends on many factors in the installation.

Note 4

Rapid attenuation is initiated by removing power to the transmitter. The transmitter power should be connected such that when the inverter shuts down the transmitter also shuts down. Fire-fighters frequently pull the power meter to cut power to the building. In a grid tied system this should also cause shutdown of the PV array. A normally closed non-momentary "Panic button" may be installed in line with the transmitter power for manual shutdown. For off grid and other systems connect the transmitter such that removing the main power will also remove power from the transmitter, thus attenuating the PV array.

Important! Restoring power to the transmitter will re-enable output from the PV array. Always ensure that it is safe to restore power before providing power to the transmitter.

Important! The MNL SOB should be tested once a year as part of regular system service.

Ratings:

| | |
|-----------------|--|
| MNL SOB-R1-1000 | 1000VDC 12 AMPS MAX - 80 VDC Panel Voltage |
| MNL SOB-R1-600 | 600VDC 12 AMPS MAX - 80 VDC Panel Voltage |
| MNL SOB-T1-AC | 90-300 VAC 50-60 Hz 3 Watts |
| MNL SOB-T1-600 | 12-16VDC 250 mA max. |

System Wiring

The wiring below diagram is of a simplified typical installation.

The MNLSOB-R1-600 or MNLSOB-R1-1000 will work with either transmitter MNLSOB-T1-600 or MNLSOB-T1-AC

The transmitter is located within or near the inverter. Either the positive or negative wire (but not both) from the string is routed through the transmitter's coupling ring. As long as the transmitter is powered it sends the keep alive signal to the receiver through the PV wire. Interrupting this signal initiates Rapid Shutdown.

MNLSOB-T1-600 and MNLSOB-R1-600 shown

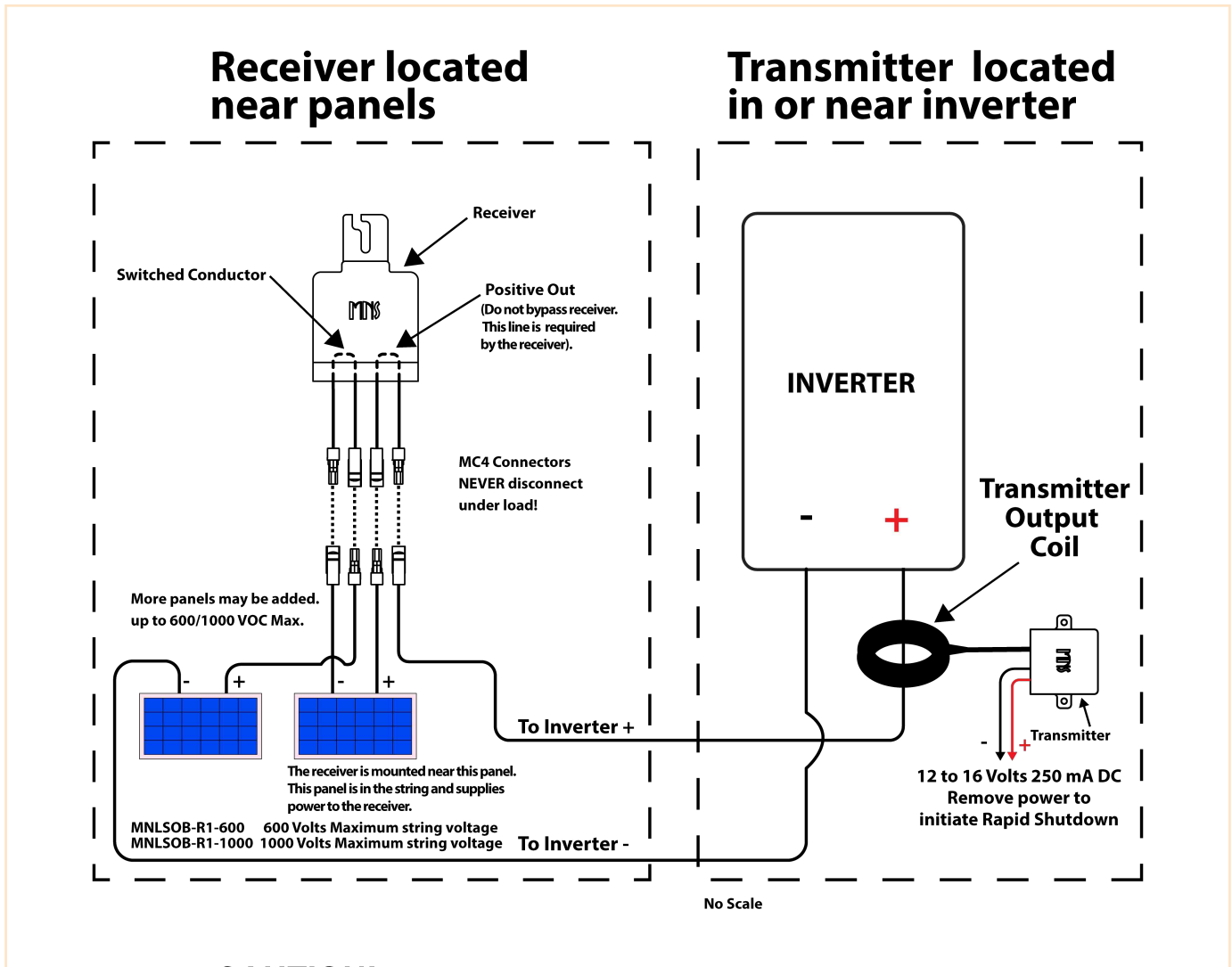

CAUTION!

PV systems may have very high voltage.

Always disconnect all sources of power and cover the solar panels.



The receiver is located near one of the panels in the string that is to have Rapid attenuation capability. Power is supplied to the receiver from the panel it is connected to. (This panel is still in the string). During normal operation the receiver transparently passes power. When the transmitter's signal is interrupted the receiver opens the circuit within a few seconds.

Pay close attention to the wiring diagram in this manual. If the receiver is wired incorrectly, damage **will** result!

System Wiring Continued

Receiver located near panels

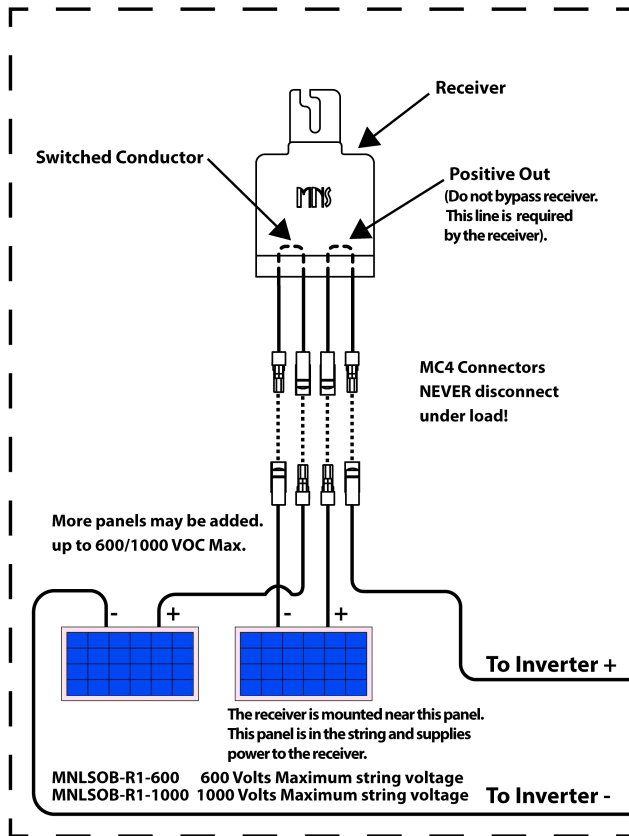

Transmitter located in or near inverter

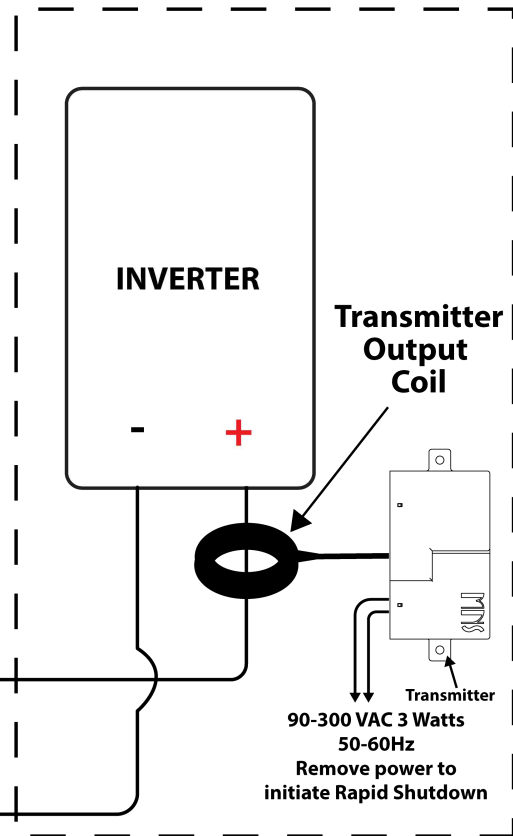

No Scale

In this configuration the 12 or 24 volt DC transmitter is replaced with the 90-300 VAC transmitter.

L.E.D. Meaning Visible through clear lens on the transmitter and receiver.

Receiver:

Yellow Blinking means the keep alive signal is being received. Red solid means the receiver is active.

Transmitter:

Red Blinking means the keep alive signal is being transmitted.

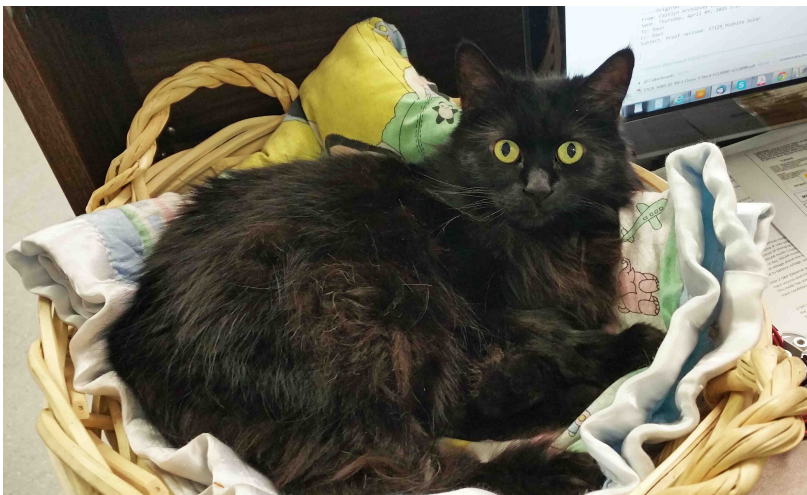

MidNite the cat Says:

"Thank you for reading the manual this far."

MIDNITE SOLAR INC. LIMITED WARRANTY

MidNite Solar Power electronics, sheet metal enclosures and accessories

MIDNITE SOLAR INC. LIMITED WARRANTY

MidNite Solar Power electronics, sheet metal enclosures and accessories

MidNite Solar Inc. warrants to the original customer that its products shall be free from defects in materials and workmanship. This warranty will be valid for a period of five (5) years for all products except the MNL SOB ten (10) years. MNBRAT Charge Controller along with the MNBIRDHOUSE1 batteries, these will be two (2) years. MidNite Solar will not warranty third party inverter components used in MidNites pre-wired systems. Those components are warranted by the original manufacturer.

At its option, MidNite Solar will repair or replace at no charge any MidNite product that proves to be defective within such warranty period. This warranty shall not apply if the MidNite Solar product has been damaged by unreasonable use, accident, negligence, service or modification by anyone other than MidNite Solar, or by any other causes unrelated to materials and workmanship. The original consumer purchaser must retain original purchase receipt for proof of purchase as a condition precedent to warranty coverage. To receive in-warranty service, the defective product must be received no later than two (2) weeks after the end of the warranty period. The product must be accompanied by proof of purchase and Return Authorization (RA) number issued by MidNite Solar. For an RMA number contact MidNite Solar Inc., 17722 67th Ave NE, Arlington, WA 98223 (360) 403-7207. Purchasers must prepay all delivery costs or shipping charges to return any defective MidNite Solar product under this warranty policy. Except for the warranty that the products are made in accordance with, the specifications therefore supplied or agreed to by customer:

MIDNITE SOLAR MAKES NO WARRANTY EXPRESSED OR IMPLIED, AND ANY IMPLIED WARRANTY OF MERCHANTABILITY OR FITNESS FOR A PARTICULAR PURPOSE WHICH EXCEEDS THE FOREGOING WARRANTY IS HEREBY DISCLAIMED BY MIDNITE SOLAR AND EXCLUDED FROM ANY AGREEMENT MADE BY ACCEPTANCE OF ANY ORDER PURSUANT TO THIS QUOTATION. MIDNITE SOLAR WILL NOT BE LIABLE FOR ANY CONSEQUENTIAL DAMAGES, LOSS OR EXPENSE ARISING IN CONNECTION WITH THE USE OF OR THE INABILITY TO USE ITS GOODS FOR ANY PURPOSE WHATSOEVER. MIDNITE SOLAR'S MAXIMUM LIABILITY SHALL NOT IN ANY CASE EXCEED THE CONTRACT PRICE FOR THE GOODS CLAIMED TO BE DEFECTIVE OR UNSUITABLE.

Products will be considered accepted by customer unless written notice to the contrary is given to MidNite Solar within ten (10) days of such delivery to customer. MIDNITE SOLAR is not responsible for loss or damage to products owned by customer and located on MIDNITE SOLAR'S premises caused by fire or other casualties beyond MIDNITE SOLAR'S control. This warranty is in lieu of all other warranties expressed or implied.

MIDNITE SOLAR INC. 17722 67TH AVE NE ARLINGTON, WA 98223

Email:

info@midnitesolar.com

PH: 360-403-7207 FAX: 360-691-6862