

# Gripper Strut

6000 Series Al

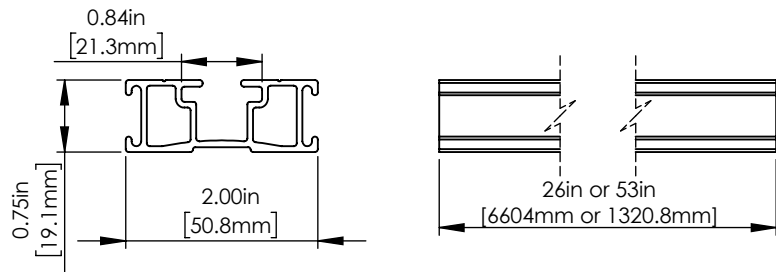

# S-5-Tab EF

6000 Series Al

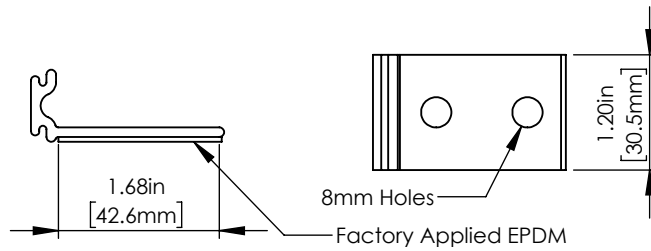

# M8-1.25 Hex Flange Bolt

Multiple Lengths Available

300 Series SS

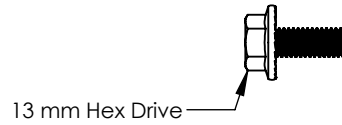

# M8 Hex Flange Nut

300 Series SS



# Self Piercing Screw

300 Series SS

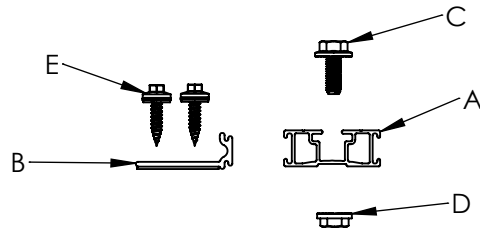
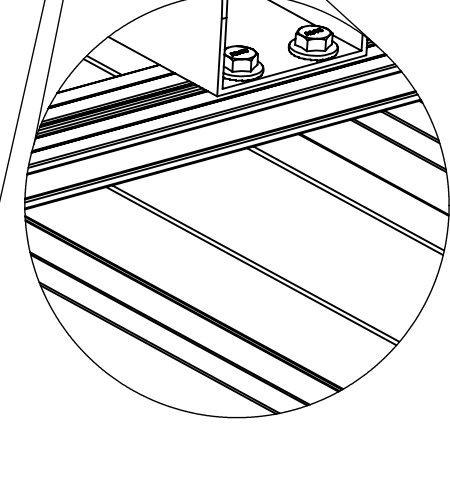
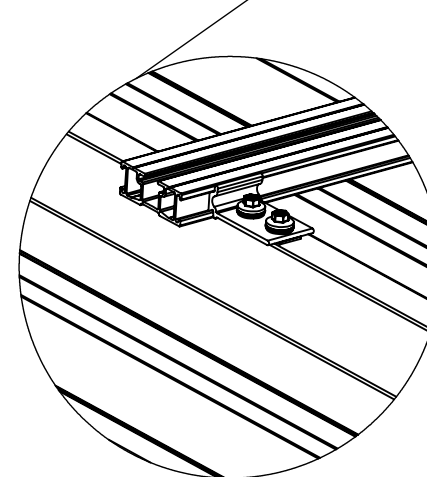
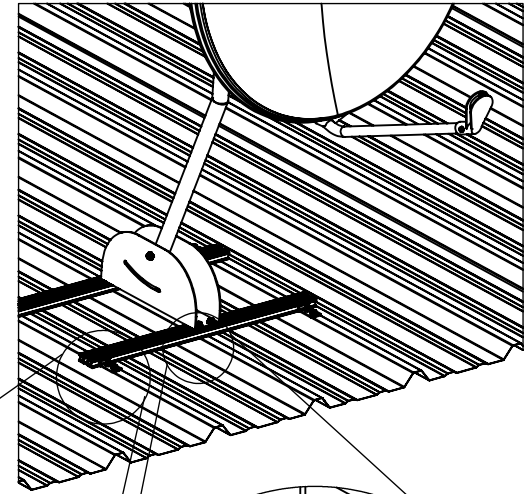

- A. Gripper Strut
- B. EF Tab
- C. M8-1.25 Hex Flange Bolt
- D. M8 Hex Flange Nut
- E. Self Piercing Screw

**FOR STANDING SEAM SPECIFIC MECHANICAL LOAD TEST INFORMATION AND CLAMP INSTALLATION INFORMATION PLEASE VISIT: [WWW.S-5.COM](http://WWW.S-5.COM)**

MATERIAL:	 METAL ROOF INNOVATIONS, LTD. 8750 WALKER RD COLORADO SPRINGS, CO 80908 719-495-0518 719-495-0045(FAX)		
EST ASSEMBLY WEIGHT:			
SUPPLIED HARDWARE:	TITLE GRIPPERFIX EF [CCD]		
SCALE: 1:2	DRAWING NO.	DRAWN BY JW	DATE 6/21/2019
S-5® PRODUCTS ARE PROTECTED BY MULTIPLE U.S. PATENTS INCLUDING 5,228,248, 5,983,588 AND 6,164,033 (OTHERS ISSUED AND PENDING). EUROPEAN PATENTS ARE ALSO APPLIED FOR AND PENDING UNDER THE PATENT COOPERATION TREATY WITH DIVISIONAL FILING RIGHTS RETAINED. METAL ROOF INNOVATIONS, LTD. (LICENSOR OF S-5!® TECHNOLOGY) AGGRESSIVELY PROSECUTES PATENT INFRINGEMENT.			