

Installation Instructions



Attention! This document is a guide only. This product may not be suitable for every application. The user is responsible for all necessary applications engineering and design. Please scan the QR code to the right for additional information, warnings and disclaimers regarding product use.

You can also view load test results at www.s-5.com where applicable, or contact your S-5! distributor for more information.

These instructions are for use by those experienced in the trade. Always follow appropriate safety precautions and use appropriate tools.

What's Included in Your Box

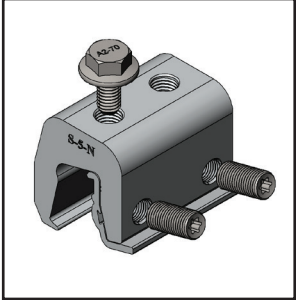
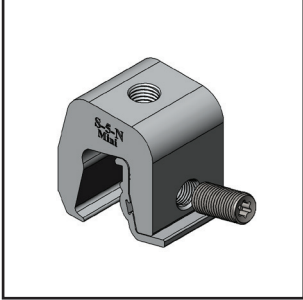
S-5-N	Based on 1 Part	S-5-N Mini	Based on 1 Part
	<ul style="list-style-type: none"> • 2 – 3/8 x .90" Setscrews (10 mm x 23 mm) • 1 – M8 x 16 mm Hex Flange Bolt • 1 – N Insert <p>Minor Box Qty: 30*</p> <p>Master Box Qty: 120*</p>		<ul style="list-style-type: none"> • 1 – 3/8 x .90" Setscrew (10 mm x 23 mm) • 1 – N Insert <p>Minor Box Qty: 50*</p> <p>Master Box Qty: 200*</p>

*Broken-box quantities may vary

Note: For the S-5-N Mini, in all applications other than a PVKIT, you will need to purchase a Hex Flange top bolt separately.

What You'll Need for Installation

- Screw Gun
- T30 Torx Bit Tip (provided)
- Dial-Calibrated Torque Wrench

(For accurate tension values, do NOT use a clicking torque wrench; inquire with S-5! for proper tool sourcing)

How to Install S-5-N and S-5-N Mini

1. Load the setscrew(s) into the clamp. (Fig 1)

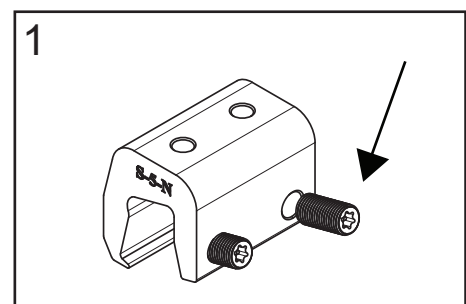

2. Position clamp and insert at desired location along the seam as shown. (Fig 2)

NOTE: On wider panel profiles, it may be necessary to place the clamp onto the seam first and then slide the insert into it. Seams that exceed maximum allowance of 0.82" at the widest part of the seam may require hand crimping to facilitate clamp fit. (Fig 2a)

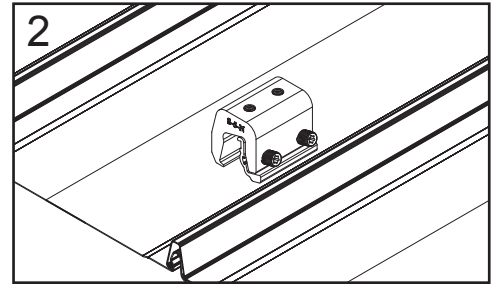

3. The clamp should be over the seam and insert as shown. (Fig 3) Make sure the toe of the clamp engages beneath the fold of the seam as shown. (Fig 3a)

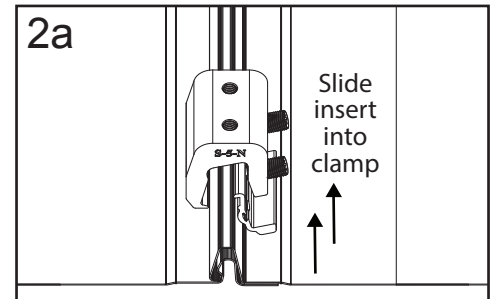

4. Tighten the setscrew(s) using a screw gun* and the included bit tip (Fig 4). When relying on published load values, setscrew tension should be verified periodically using a dial-indicating calibrated torque wrench to ensure the tool is consistently achieving the recommended torque range (Table 1).

When installing the **S-5-N clamp**: Setscrews should be alternately tensioned as shown in Fig 4a until both setscrews have achieved recommended torque.

When installing the **S-5-N Mini clamp**: The seam material will compress evenly during the first tightening.

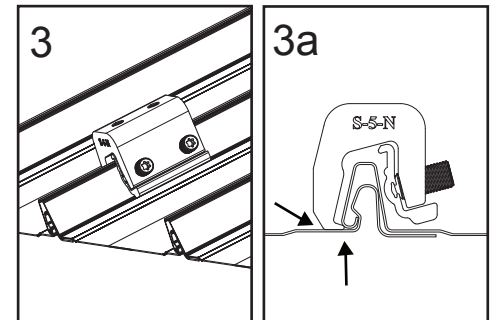

5. Attach your ancillary and tighten the bolt. For critical attachment applications, reference Table 1 for the appropriate torque.

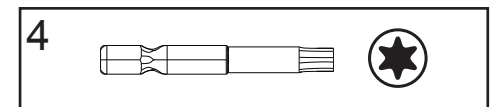
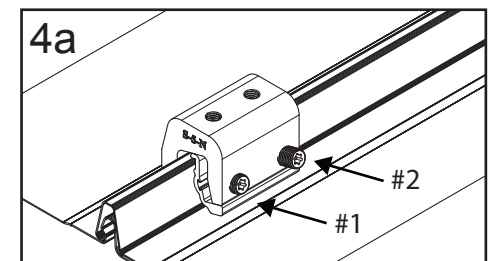

Table 1

Specified Torque	Inch Pounds	Foot Pounds	Nm
Setscrew on 22ga (0.8 mm) steel	160-180	13-15	18-20
Setscrew on 24ga (0.6 mm) steel and all other materials	130-150	11-12.5	15-17
M8 Hex Flange bolt	160	13	18



Once installed correctly, the mechanical interlock is established and these clamps require no maintenance or torque re-inspection for the life of the roof.

NOTE: Any S-5! warranty and/or calculation may be void if hardware is used that was not furnished by S-5! directly or through one of their licensed distributors or any assembly that has not been tested by S-5!

S-5!® Warning! Please use this product responsibly!

Products are protected by multiple U.S. and foreign patents. For published data regarding holding strength, fastener torque, patents, and trademarks, visit the S-5! website at www.S-5.com. Copyright 2022, Metal Roof Innovations, Ltd. S-5! products are patent protected. S-5! aggressively protects its patents, trademarks, and copyrights. ProteaBracket-V1.0-1022