



# HIGH VOLTAGE BATTERY INTEGRATION GUIDE

COMMERCIAL & INDUSTRIAL APPLICATIONS

TB-00029 REV 2

Effective Date: October 14, 2025





## About this Guide

This Battery Integration Guide provides general assistance with integrating Sol-Ark or third-party batteries with Sol-Ark manufactured hybrid inverters. It is not intended to substitute for, or to replace, the guidance or services of trained installers, engineers or other specialists that are responsible for system installation, design, testing and performance. It should not replace or modify any of the technical, support or other information made available by the Battery manufacturer, including information related to safety and performance established by the Battery manufacturer.

Consult with the Battery manufacturer and those responsible for installation, testing, and system performance before undertaking any of the integration steps in this Guide. In-depth configurations, step-by-step instructions, troubleshooting, and verification of operational parameters are not addressed in this Guide and are outside its scope.

Battery technology is constantly evolving, so new features, requirements, or compatibility considerations may arise. Please stay informed about the latest developments and recommendations from both Sol-Ark and the battery manufacturer.

Sol-Ark does not offer technical support for battery communications with battery models not listed in this guide. Any damage caused to the inverter due to the use of unsupported battery communications is NOT covered by Sol-Ark's warranty.

Please read the full Disclaimer on page 33 before proceeding.

This guide is for only **High-Voltage Hybrid Sol-Ark Inverters**.

## Contact Us

+1 (972) 575-8875 ext. 2

Support@Sol-Ark.com

[www.Sol-Ark.com](http://www.Sol-Ark.com)



# Contents

<b>General Hardware Configuration</b> .....	<b>1</b>
Sol-Ark 30K-3P-208V and Sol-Ark 60K-3P-480V .....	1
Wiring 2 .....	
CANBus Battery Screen .....	3
Connecting Batteries.....	4
Communications Cable Requirements .....	4
<b>Sol-Ark Storage Partners</b> .....	<b>5</b>
Why Sol-Ark? .....	5
Sol-Ark Batteries.....	5
<b>Sol-Ark L3-HVR-60</b> .....	<b>6</b>
Compatible Configurations.....	6
Batteries Supported by the 30K-3P-208V.....	6
Batteries Supported by the 60K-3P-480V.....	6
Communications Installation and Setup Instructions .....	7
Custom RJ45 cable .....	7
Inverter programming and connections.....	7
<b>Sol-Ark L3-HV-60 / L3-HV-40</b> .....	<b>9</b>
Compatible Configurations.....	9
Batteries Supported by the 30K-3P-208V.....	9
Batteries Supported by the 60K-3P-480V.....	9
Communications Installation and Setup Instructions .....	9
Custom RJ45 cable .....	9
Battery IDs and connections .....	9
Inverter programming and connections.....	10
<b>Certified Storage Partners</b> .....	<b>12</b>
<b>Deka Duration – DD5300 (High Voltage Configuration)</b> .....	<b>13</b>
Compatible Configurations.....	13
Batteries Supported by the 30K-3P-208V.....	13
Batteries Supported by the 60K-3P-480V.....	13
Before you start .....	14
Communications Installation and Setup Instructions .....	15
Custom RJ45 cable .....	15
Battery IDs and connections .....	15
Inverter programming and connections.....	16
<b>Discover Energy Systems - AES 210HV</b> .....	<b>18</b>
Compatible Configurations.....	18
Batteries Supported by the 60K-3P-480V .....	18
Before you start .....	18
Communications Installation and Setup Instructions .....	19
Battery IDs and connections .....	19
Inverter programming and connections .....	19



<b>EndurEnergy – ESP-5K HL .....</b>	<b>20</b>
Compatible Configurations .....	20
Batteries Supported by the 30K-3P-208V .....	20
Batteries Supported by the 60K-3P-480V .....	20
Communications Installation and Setup Instructions .....	21
Custom RJ45 cable .....	21
Battery IDs and connections .....	21
Inverter programming and connections.....	21
<b>Pylontech - PowerCube-M1-C &amp; OPTIM US A100-HY-UL.....</b>	<b>23</b>
Compatible Configurations Batteries Supported by the 30K-3P-208V .....	23
Batteries Supported by the 60K-3P-480V .....	23
Before you start .....	23
Communications Installation and Setup Instructions .....	24
Battery IDs and connections .....	24
Inverter programming and connections .....	25
Single Battery Stack .....	25
Paralleling Two or More Battery Stacks.....	26
<b>Pytes - HV48100.....</b>	<b>27</b>
Compatible Configurations Batteries Supported by the 30K-3P-208V .....	27
Batteries Supported by the 60K-3P-480V .....	27
Before you start .....	27
Communications Installation and Setup Instructions .....	28
Custom RJ45 cable .....	28
Battery IDs and connections .....	28
Inverter programming and connections .....	28
Paralleling Two or More Battery Stacks.....	30
<b>Renon R-EC060030A1-US &amp; R-EC060060A1-US.....</b>	<b>31</b>
Compatible Configurations.....	31
Renon batteries supported by the Sol-Ark 30K-3P-208V .....	31
Renon batteries supported by the Sol-Ark 60K-3P-480V .....	31
Before you start .....	31
Communications Installation and Setup Instructions .....	32
Custom RJ45 cable .....	32
Battery IDs and connections .....	32
Inverter programming and connections .....	32
Single Battery Stack .....	32

This document covers high-voltage battery integration with Sol-Ark’s high-voltage hybrid inverters.



**Update to Latest Inverter Firmware**

For reliability of CANBus communication, update to COMM Software Version 1040 and MCU Software Version 1086 or greater.

**Update to Latest Battery Firmware**

Contact Sol-Ark Technical Support or the battery manufacturer for the latest firmware version.



# General Hardware Configuration

## Sol-Ark 30K-3P-208V and Sol-Ark 60K-3P-480V

Sol-Ark 30K-3P-208V and 60K-3P-480V inverters communicate with the battery through two ports, **BMS1** and **BMS2**. Both **BMS1** and **BMS2** ports can do CANBus communication.

The diagram shows the communication board inside the 30K inverter wiring area. Note that only the **BMS1** and **BMS2** ports are used for battery communications. The table lists PIN configurations for CANBus communication of this RJ45.

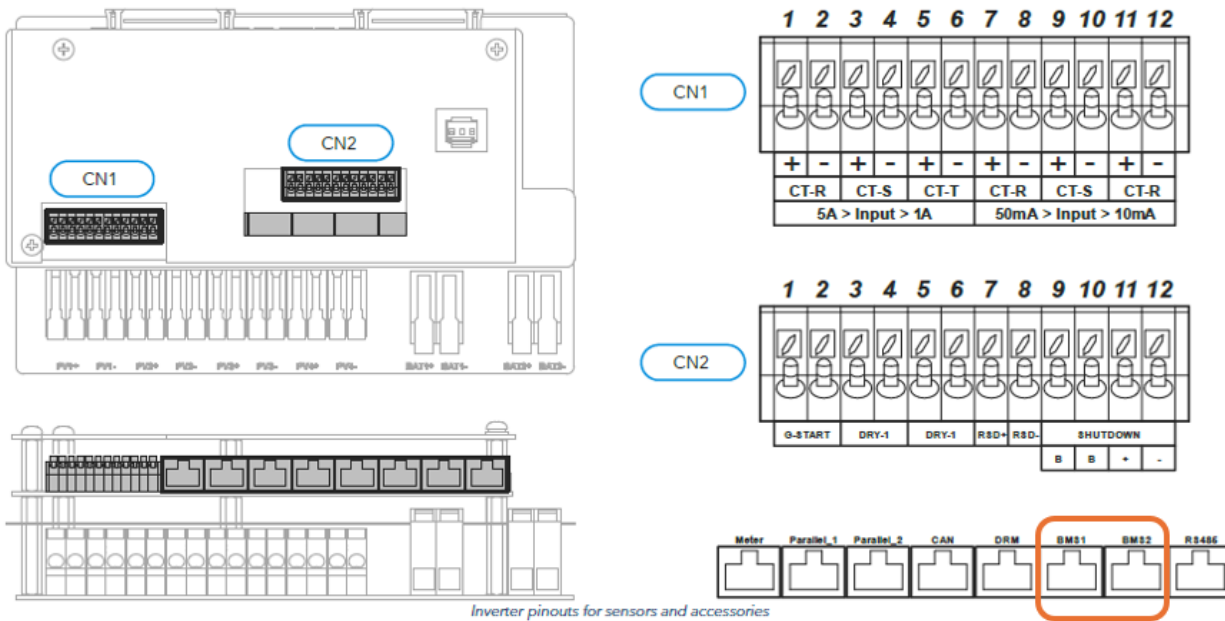

**Table I:** RS-485 Pin Configurations of Battery CANBus Port for ModBus and CANBus Protocols

Pin	CANBus
1	B-
2	A+
3	--
4	CAN Hi
5	CAN Lo
6	GND
7	A+
8	B-



## Wiring

The two battery input terminals of the 30K-3P-208V and 60K-3P-408V will parallel batteries internally to ensure a common connection between battery banks, and to simplify battery installations. If you need a charge/discharge rate of 100A, the batteries must be connected to both input terminals. If you use 3 or more batteries, use external busbars for (+) and (-) connections.

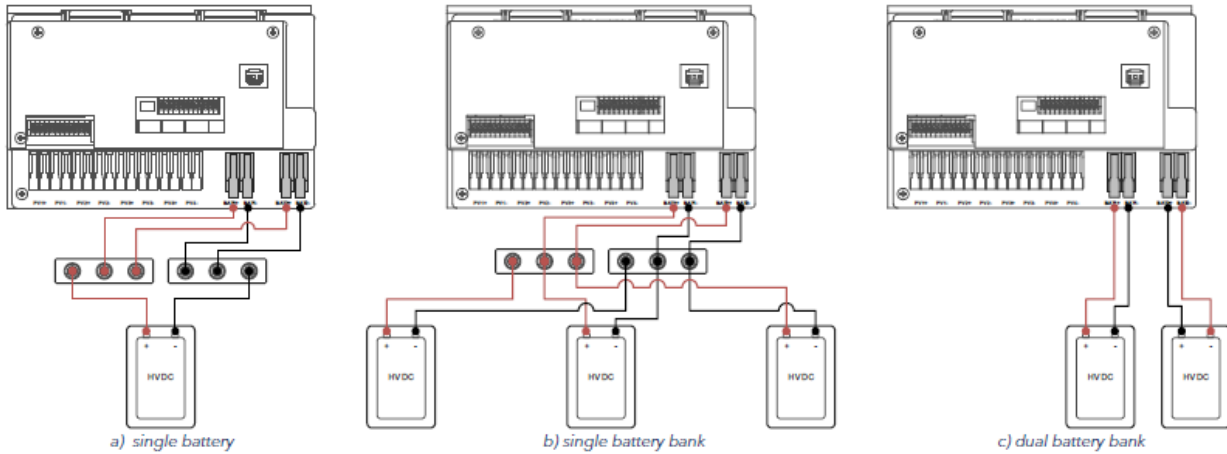

All lithium-ion batteries have defined minimum, nominal, and maximum current output ratings. The full output power of a Sol-Ark inverter can be guaranteed only if the battery output capacity matches the inverter size.

Pay special attention to the battery manufacturer's rated or warranted specifications, and follow the minimum configurations shown later in this guide. Use the battery model and number of battery modules as a baseline reference. This will ensure your setup meets the nominal and overload ratings specified in the 30K-3P-208V or 60K-3P-480V data sheet.



## CANBus Battery Screen

This is what the **Li Batt Info** screen looks like when communications are enabled for CANBus batteries (**BMS Lithium Batt 00**).

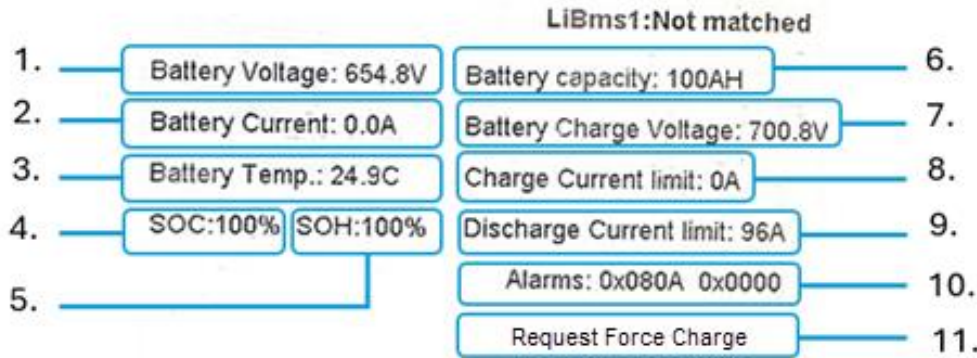

- |                                   |   |
|-----------------------------------|---|
| <b>1. Battery Voltage</b>         | Real-time voltage measured between the battery terminals  |
| <b>2. Battery Current</b>         | Real-time current flowing into or out of battery's + terminal (-/+ sign respectively)   |
| <b>3. Battery Temp</b>            | Real-time temperature measured at the BMS   |
| <b>4. SOC</b>                     | State Of Charge remaining in the battery, according to the BMS  |
| <b>5. SOH</b>                     | State Of Health of the battery, according to the BMS  |
| <b>6. Battery capacity</b>        | Amp-hour design capacity of the battery (not used on all batteries)   |
| <b>7. Battery Charge Voltage</b>  | The inverter should charge the battery to the maximum voltage   |
| <b>8. Charge Current limit</b>    | Maximum current allowed to the battery  |
| <b>9. Discharge Current limit</b> | Maximum current allowed out of the battery  |
| <b>10. Alarms</b>                 | Displays alarm codes from ONLY the L3-HV-40, L3-HV-40 and L3-HVR-60 battery   |
| <b>11. Force Charge Request</b>   | This field is normally blank, but it displays <b>Request Force Charge</b> when the BMS tells the inverter to charge the battery from any available power source, regardless of inverter settings. |



## Connecting Batteries

When creating a custom RJ45 cable, use a cable with the following specifications.

### Communications Cable Requirements

<b>Conductors:</b>	4x Twisted Pairs (8x Conductors)
<b>Cable Category:</b>	CAT5e or better
<b>Conductor Gauge:</b>	24 AWG to 16 AWG (0.25 mm <sup>2</sup> to 0.34 mm <sup>2</sup> )
<b>Max. Cable Length:</b>	6 m (20 ft)

- **When installed in a Battery DC conduit or wiring tray**, the cable jacket must be rated for 600V or sleeved to provide equivalent protection.
- **When installed outdoors**, the cable jacket **must** be UV-resistant and listed for outdoor use. Sol-Ark recommends CAT6ODSH-EA or similar.

The Installer should consult battery manufacturer instructions to ensure compliance with any additional requirements.

Most custom cables are NOT reversible; therefore, keep track of which end of the custom cable connects to the battery and the Sol-Ark.



If you're crimping new RJ45 connectors to create a cable, be careful not to over-tighten the adjustment screw on the crimping tool, as this can recess the connectors and lead to a poor or intermittent connection.



## Sol-Ark Storage Partners

Sol-Ark recognizes three levels of storage partners: *Preferred*, *Certified*, and *Proven*.

Sol-Ark currently offers the only High Voltage Batteries considered *Preferred*. Sol-Ark's fully integrated and supported battery solutions are engineered for optimal compatibility with our inverters, and we have a documented history of successful battery installations with Sol-Ark inverters.

This guide includes general instructions for Sol-Ark's **Certified Storage Partners** starting on page 12.



**Note:** The scope of this guide is limited to battery manufacturers with approved partnerships with Sol-Ark. Integration between Sol-Ark high-voltage inverters and non-partnered batteries is not supported.

### Why Sol-Ark?

- Sol-Ark has a track record of seamless integration and reliable performance with Sol-Ark inverters.
- We offer reputable products and robust customer support.
- Sol-Ark has significant experience connecting its batteries and inverters, ensuring a solid foundation for system integration.
- Sol-Ark product manuals and data sheets are designed to help our customers select the power output and energy storage solution they need.
- We fully support service calls with the necessary battery diagnostic methods within our general configuration and troubleshooting methods (comms connection, electrical, battery parameters).

### Sol-Ark Batteries

Sol-Ark's two batteries integrate seamlessly with Sol-Ark inverters:

Battery Model	BMS Lithium Battery	Custom cable required?
L3-HVR-60	00	No
L3-HV-60 / L3-HV-40	00	No



## Sol-Ark L3-HVR-60

Follow these instructions for setting up Sol-Ark HVR batteries and Sol-Ark inverters.



Be sure to **consult Sol-Ark’s comprehensive technical documentation** for specifications and settings to ensure optimal performance and safety. Click the link below to visit the Sol-Ark website and consult relevant documentation.



[Sol-Ark documentation](#)

### Compatible Configurations

#### Batteries Supported by the 30K-3P-208V

Battery Model	Min/Max # of Modules	Supported BMS Firmware	Supported Gateway Firmware (if applicable)
L3 HVR-60	6S2P only	HVGEF6024B28N01_1207	N/A

#### Batteries Supported by the 60K-3P-480V

Battery Model	Min/Max # of Modules	Supported BMS Firmware	Supported Gateway Firmware (if applicable)
L3 HVR-60	12S1P only	HVGEF6024B28N01_1207	N/A



# Communications Installation and Setup Instructions

## Custom RJ45 cable

A custom RJ45 cable is not required. A standard RJ45 connector-based CAT5/CAT6 Ethernet cable is suitable for this application.

## Inverter programming and connections

### Single Cabinet

1. Connect a standard CAT5/6 cable to the **Surge Protection Device (SPD)**, also referred to as **SPD1** on the cabinet, to the **BMS1** port on the Sol-Ark inverter.
2. Program the inverter with the appropriate Max A charge/discharge settings according to the specific battery manual and cable arrangement.
3. Enable **BMS Lithium Batt** and set its value to **00**.

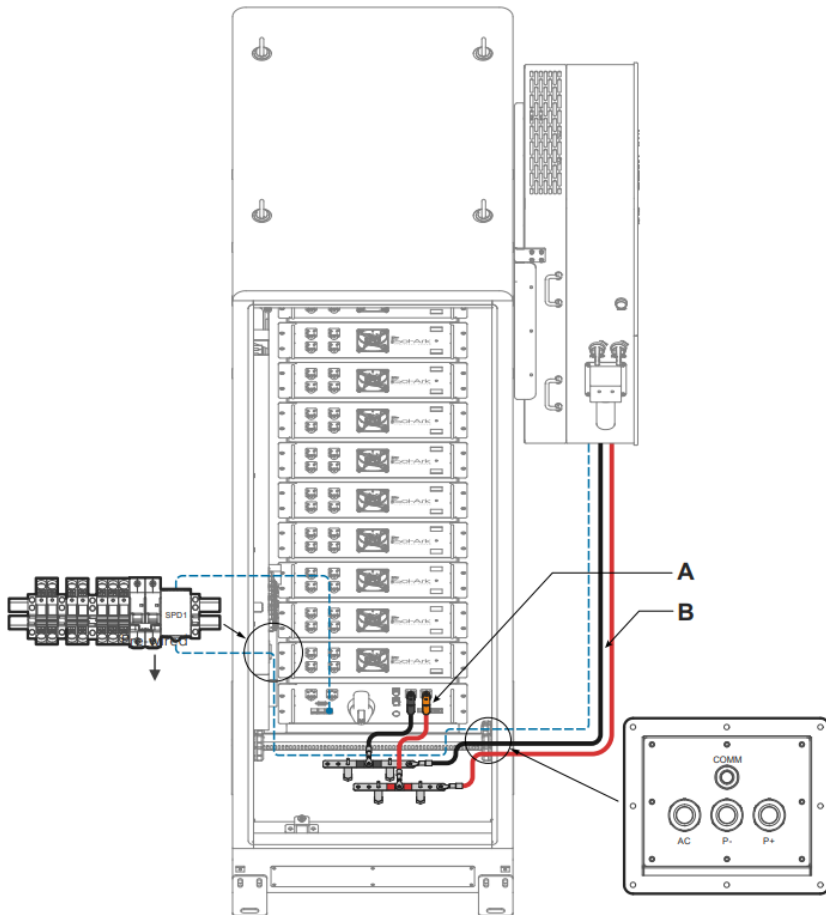



## Paralleling Two or More Cabinets

1. Connect a standard CAT5/6 cable to the **HVOUT** port in the “Master” battery to the **HVIN** port in the “Slave” battery.

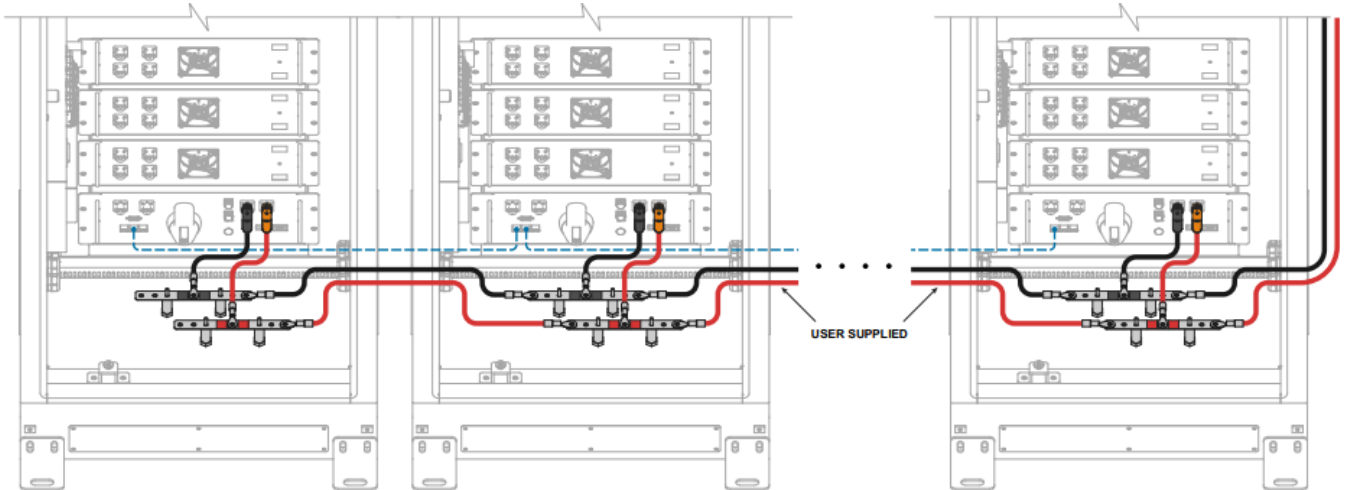

2. Connect a standard CAT5/6 cable to the **SPD** breaker in the “Master” cabinet, to the **BMS** port in the Sol-Ark inverter.
3. Program the inverter with the appropriate Max A charge/discharge settings according to the specific battery manual and cable arrangement.
4. Enable **BMS Lithium Batt** and set its value to **00**.

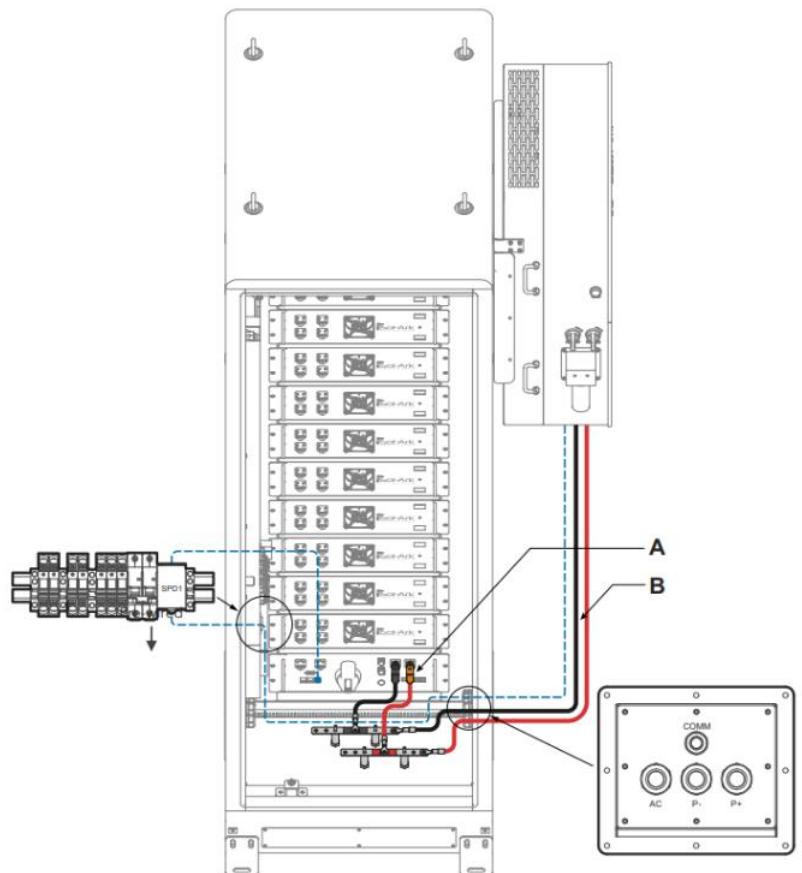



## Sol-Ark L3-HV-60 / L3-HV-40

Follow these instructions for setting up Sol-Ark L3 HV batteries and Sol-Ark inverters.



Be sure to **consult Sol-Ark's comprehensive technical documentation** for specifications and settings to ensure optimal performance and safety. Visit the manufacturer's website and consult the relevant documentation below.



[Sol-Ark documentation](#)

### Compatible Configurations

#### Batteries Supported by the 30K-3P-208V

Battery Model	Min/Max # of Modules	Supported BMS Firmware	Supported Gateway Firmware
L3 HV-40	8S only	HVCUE1625707ARK_1007	N/A

#### Batteries Supported by the 60K-3P-480V

Battery Model	Min/Max # of Modules	Supported BMS Firmware	Supported Gateway Firmware (if applicable)
L3 HV-60	12S only	HVCUE1625707ARK_1007	N/A

### Communications Installation and Setup Instructions

#### Custom RJ45 cable

A custom RJ45 cable is not required. A standard RJ45 connector-based CAT5/CAT6 Ethernet cable is suitable for this application.

#### Battery IDs and connections

- Connect the communication cables between modules and the BMU.
- Proceed with the serial connection between all the modules and BMU.

See the *Installation & Operation (I&O) Manual* to follow the correct startup and shutdown procedures for each battery configuration.



## Inverter programming and connections

### Single Battery Stack

When using a single stack, communication will be done between the BMS and the inverter.

1. Connect the cable to the **PCS** port on the BMS to the **BMS1** port on the inverter.
2. Program the inverter with the appropriate Max A charge/discharge settings according to the specific battery manual and cable arrangement
3. Enable **BMS Lithium Batt** and set its value to **00**.

**Inverter**  
60K-3P-480V (L3 HV-60) or 30K-3P-208V (L3 HV-40)

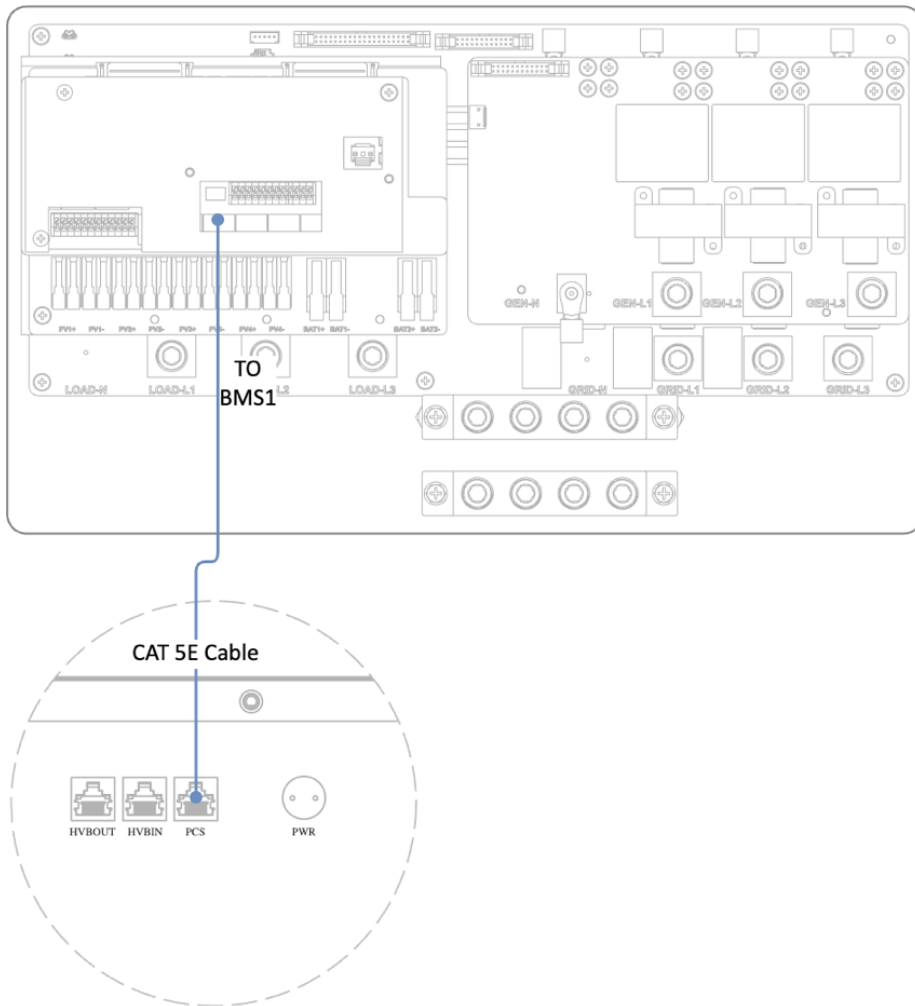





## Certified Storage Partners

The following batteries have been tested with Sol-Ark's high-voltage inverters, and they are certified to work with our inverters.

Manufacturer	Battery Model	BMS Lithium Batt Protocol ID	Custom cable required?
Deka by MK Battery	Deka Duration DD5300 LV/HV	00	Yes
Discover Energy Systems	AES 210HV	00	No
EndurEnergy Systems	ESP-5K HL	00	No
Pylontech	PowerCube-M1-C	00	Yes
Pytes	HV48100	00	Yes

*Certified* means:

- Sol-Ark tested communications and electrical capability of our respective products.
- We collaborate on critical safety and regulatory requirements to ensure our customers are able to commission and permit our joint solutions.
- We have an agreement to ensure ongoing product compatibility and to ensure the highest level of product reliability, support, and customer service.
- Partners in this category have at least one battery model that has passed Sol-Ark's testing and certification process.



# Deka Duration – DD5300 (High Voltage Configuration)

Follow these instructions for setting up Deka batteries and Sol-Ark inverters.



Be sure to **consult MK Deka’s comprehensive technical documentation** for specifications and settings to ensure optimal performance and safety. Click the link below to visit the Deka website and consult their documentation.



[Deka documentation](#)



Communication with this battery requires a custom cable.

## Compatible Configurations

### Batteries Supported by the 30K-3P-208V

Battery Model	Min/Max # of Modules	Supported BMS Firmware	Supported Gateway Firmware
DD5300	6S to 8S	<b>HV BOX FW:</b> WE_E1_05007_HVBOXUL_20240801 <b>Module FW:</b> WE_F4_02021_5K3XPUL_20240222	N/A

### Batteries Supported by the 60K-3P-480V

Battery Model	Min/Max # of Modules	Supported BMS Firmware	Supported Gateway Firmware
DD5300	12S only	<b>HV BOX FW:</b> WE_E1_05007_HVBOXUL_20240801 <b>Module FW:</b> WE_F4_02021_5K3XPUL_20240222	N/A

You can see the firmware version of the batteries using a phone application or special PC software. See the manufacturer's instructions for details.



## Before you start

- See the MK Deka *Installation & Operation (I&O) manual* to proceed with the serial battery wiring connections and verify the proper communications configuration of CANBus connections and DIP switch settings.
- You must use an HV Box for a single cluster and a DT8-24 Combiner (HUB) for two or more clusters connected in parallel. The high voltage mode mandates that the battery modules must be connected in series.
- Verify the firmware versions of the battery modules, HV Box, and DT8-24 Combiner. Contact MK Deka support to confirm compatibility and obtain necessary updates.

**Note:** The battery module for the MK Deka DD5300 is used for both their low voltage and high voltage batteries, but a different DIP switch and wiring configuration is required for each. See the MK Deka manual and this integration guide for installation instructions.



## Communications Installation and Setup Instructions

### Custom RJ45 cable

Create a custom RJ45 cable to establish communication between the battery and the inverter. The PIN configuration depends on whether you're installing a single battery cluster or multiple battery clusters.

CAN Terminal	Inverter Terminal Type	Inverter side PIN Number	Battery side Single Cluster PIN Number	Battery side Multiple Cluster PIN Number
CAN L	RJ45	5	2	8
CAN H		4	1	7
GND		6	3	6

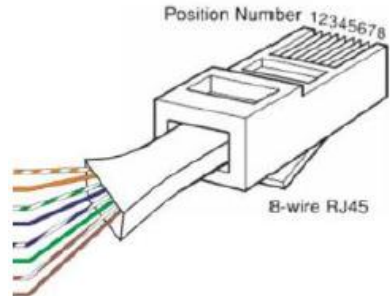

### Battery IDs and connections

1. Set the DIP Switches for the battery modules and HV Box according to the number of clusters. See the MK Deka *Installation & Operation (I&O) manual* for configuration details.
2. Connect the communication cables between modules and the HV Box.
3. Proceed with the serial connection between all the modules and HV Box.

See the *Installation & Operation (I&O) manual* for the correct startup and shutdown procedures for each battery configuration.



## Inverter programming and connections

### Single or Dual Battery Stack

When using a single stack, communication will be between the HV Box and the inverter.

1. Connect the communication cable to the HV Box's **CAN PORT 2-A** port, then connect the communication cable to the inverter's **BMS1** port.

For the second battery stack, do the same as the above, but connect the HV Box's **CAN PORT 2-A** to the inverter's **BMS2** port.

2. Program the inverter with the appropriate Max A charge/discharge settings according to the specific battery manual and cable arrangement
3. Enable **BMS Lithium Batt** and set its value to **00**.

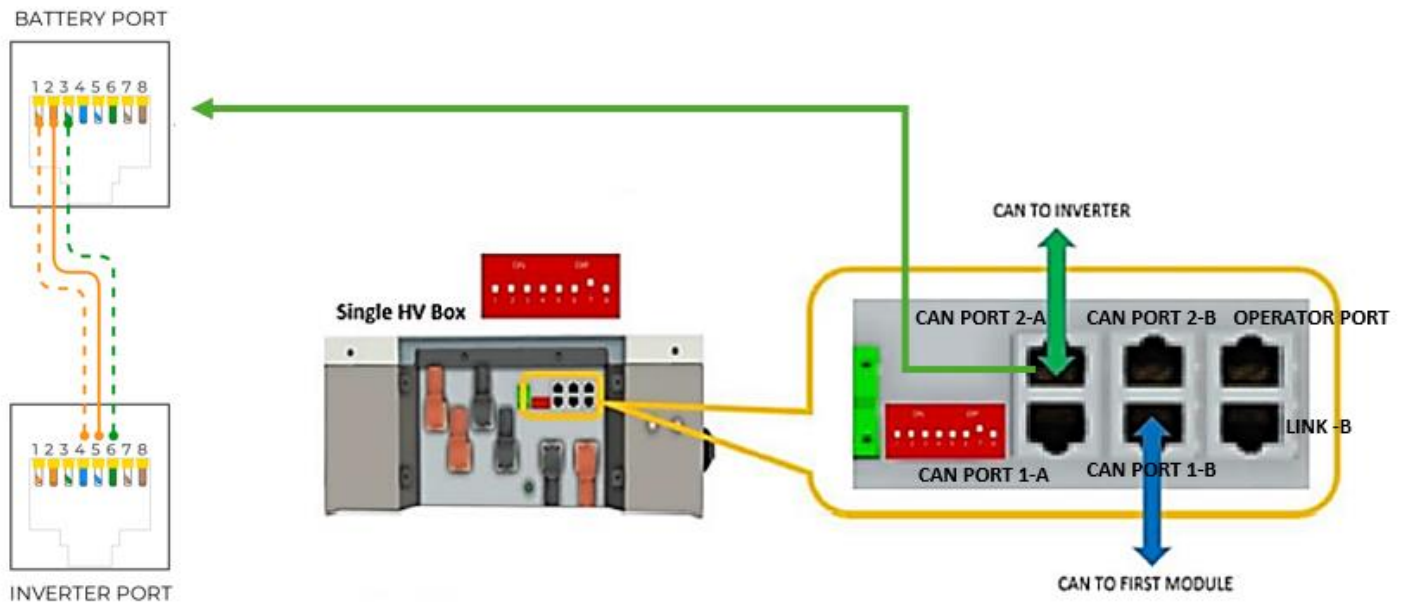



## Paralleling Two or More Battery Stacks

When paralleling more than two stacks, Deka requires the **DT8-24 Combiner (HUB)**. Two custom RJ45 cables are required for this setup:

1. The RJ45 cable allows communication between HV Boxes:

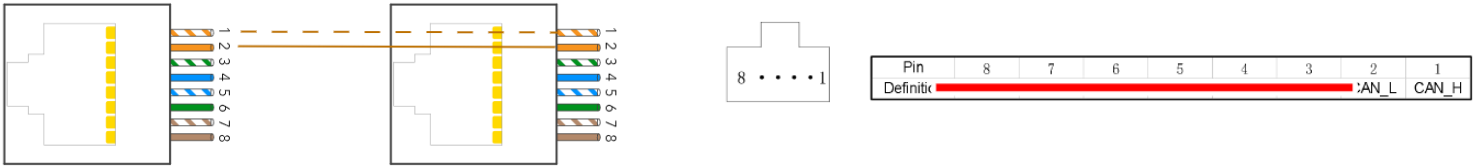

2. The RJ45 cable allows communication between the DT8-24 Combiner (HUB) and inverter:

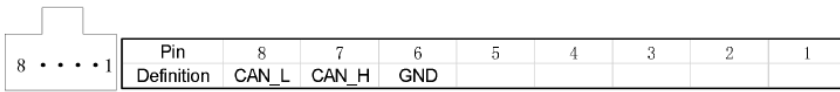

Communication will be done between the HUB and the inverter.

3. Connect the cable to the **CAN2/INVERTER** port on the HUB to the **BMS1** port on the inverter.
4. Program the inverter with this battery's appropriate charge/discharge settings.
5. Enable **BMS Lithium Batt** and set its value to **00**.

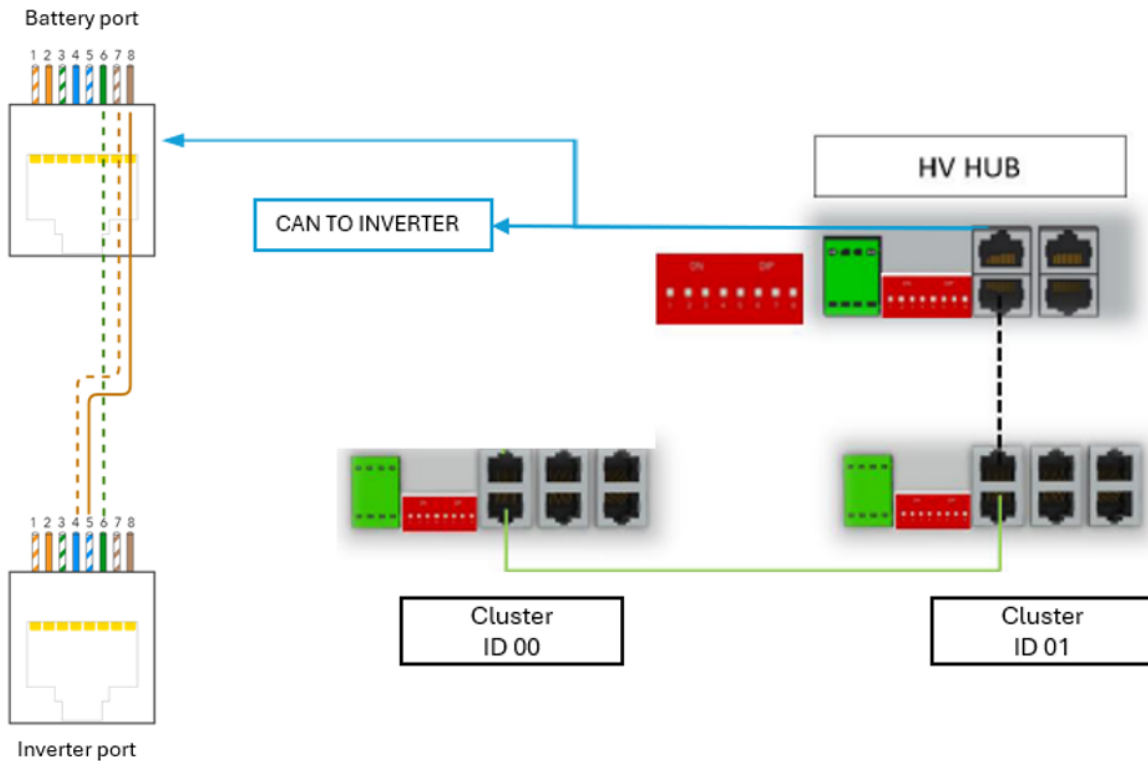



## Discover Energy Systems - AES 210HV

Follow these instructions for setting up Discover batteries and Sol-Ark 60K inverters.

Be sure to consult Discover’s comprehensive technical documentation for specifications and settings to ensure optimal performance and safety.

Click the link below to visit Discover’s website and consult their documentation.

[Discover documentation](#)

### Compatible Configurations

**Note:** The AES210HV battery system is designed for use with the 60K-3P-480V inverter only. Compatibility with the Sol-Ark 30K-3P-208V inverter is not supported, as the AES210 HV nominal voltage exceeds the voltage parameters of the 30K-3P-208V system.

### Batteries Supported by the 60K-3P-480V

Battery model	Min/Max # of Modules	Supported BMS Firmware	Supported Gateway Firmware
AES 210HV	4 packs @ 52S1P	2002	LYNK II 2.2.2.0

You can see the firmware version of the batteries using Discover’s PC software. See the manufacturer's instructions for details.

### Before you start

- See the *Installation & Commissioning Manual* to proceed with the serial battery wiring connections and verify the proper communications configuration of CAN Bus connections.
- You must use a LYNK II Gateway. The high-voltage mode requires that the battery packs be connected in series.
- Verify the firmware versions of the battery modules and a LYNK II Gateway. Contact Discover support to confirm compatibility and obtain necessary updates.



## Communications Installation and Setup Instructions

### *Custom RJ45 cable*

A custom RJ45 cable is not required. A standard RJ45 connector-based CAT5/CAT6 Ethernet cable is suitable for this application.

## Battery IDs and connections

1. Connect the communication cables between the battery modules, HV Box, and the LYNK II Gateway.
2. Proceed with the serial connection between all battery packs and the HV Box. See the *Installation & Commissioning manual* for the correct startup and shutdown procedures for each battery configuration.

## Inverter programming and connections

### **Single or Dual Battery cabinets**

When using a single or dual battery cabinet setup, communication will be between the LYNK II Gateway and the inverter.

1. Connect the LYNK II Gateway device CANBUS output to the inverter's BMS1 port. If using two battery cabinets, the LYNK II Gateway from cabinet #2 connects to the inverter's BMS2 port.
2. Program the inverter with the appropriate Max A charge/discharge settings according to the specific battery manual and cable arrangement.
3. Enable **BMS Lithium Batt** and set its value to **00**.



# EndurEnergy – ESP-5K HL

Follow these instructions for setting up EndurEnergy batteries and Sol-Ark inverters.



Be sure to consult EndurEnergy’s comprehensive technical documentation for specifications and settings to ensure optimal performance and safety. Click the link below to visit the EndurEnergy website and consult their documentation.



[EndurEnergy documentation](#)

**Note:** The battery module for the EndurEnergy ESP-5K HL is used for both their low voltage and high voltage batteries, but each requires a different DIP switch and wiring configuration. See the EndurEnergy manual and this integration guide for installation instructions.

## Compatible Configurations

### Batteries Supported by the 30K-3P-208V

Battery Model	Min/Max # of Modules	Supported BMS Firmware	Supported Gateway Firmware
ESP-5K HL	8S only	<b>BCU FW:</b> ENDURZ_GYH_ESP_V1507_250124_V-T5 <b>Module FW:</b> ENDURZ_U_GD305_V215B_231110_V-T5	<b>N / A</b>

### Batteries Supported by the 60K-3P-480V

Battery Model	Min/Max # of Modules	Supported BMS Firmware	Supported Gateway Firmware
ESP-5K HL	12S only	<b>BCU Firmware:</b> ENDURZ_GYH_ESP_V1507_250124_V-T5 <b>Module Firmware:</b> ENDURZ_U_GD305_V215B_231110_V-T5	N/A

You can see the firmware version of the batteries using a phone application or special PC software. See the manufacturer's instructions for details.



# Communications Installation and Setup Instructions

## Custom RJ45 cable

A custom RJ45 cable is not required. A standard RJ45 connector-based CAT5/CAT6 Ethernet cable is suitable for this application.

## Battery IDs and connections

1. Use the provided RJ45 cable to connect all EndurEnergy ESP-5k HL batteries using **M/S** ports.
2. Set all the dip switches according to the battery manual.
3. Double-check all dip switches on all batteries in the battery bank.

## Inverter programming and connections

### Single Battery Stack

1. Connect a standard CAT5/6 cable to the **Inverter** port on the ESP-5K Master battery, and then to the **CAN1** port on the Sol-Ark inverter.
2. Program the inverter with the appropriate Max A charge/discharge settings according to the specific battery manual and cable arrangement.
3. Enable **BMS Lithium Batt** and set its value to **00**.

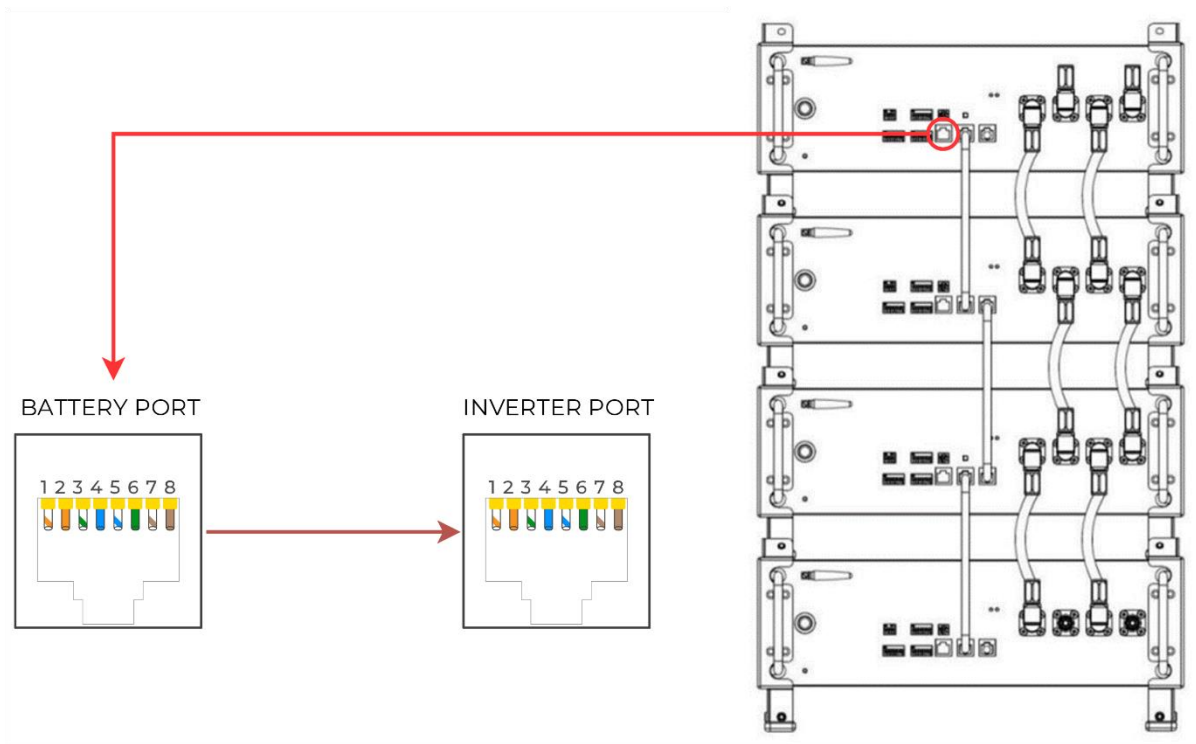



### Paralleling Two Battery Stacks or More

1. Connect a standard CAT5/6 cable to the **Cluster** port on the BCU, and the **MS** port in each “Master” battery in each cluster.
2. Set all the dip switches according to the BCU manual, then double-check all dip switches in the BCU and all batteries in the battery banks.



3. Connect a standard CAT5/6 cable to the **CAN** port on the BCU, to the **BMS1 and BMS2** port in the Sol-Ark inverter.

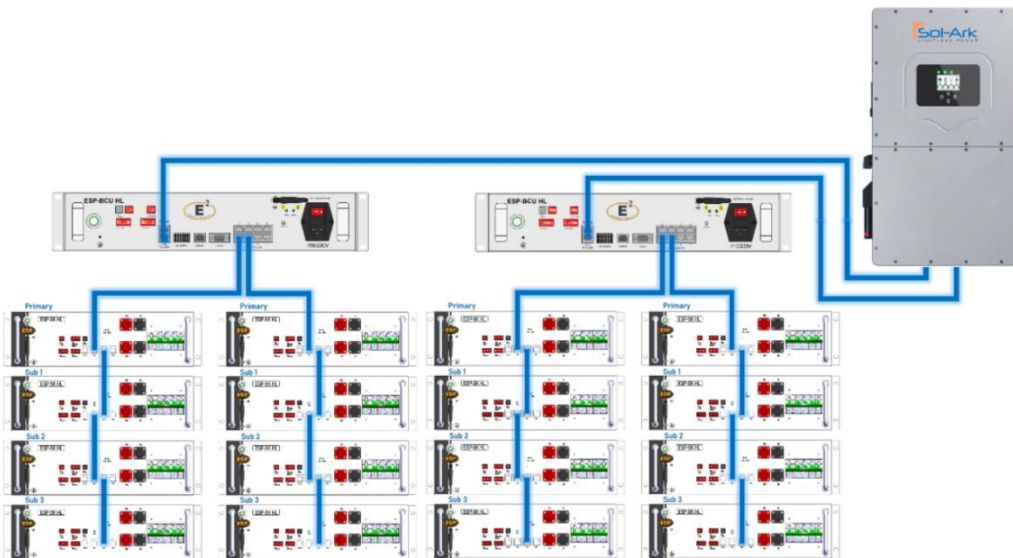

4. Program the inverter with the appropriate Max A charge/discharge settings according to the specific battery manual and cable arrangement.
5. Enable **BMS Lithium Batt** and set its value to **00**.



## Pylontech - PowerCube-M1-C & OPTIM US A100-HY-UL

Follow these instructions for setting up Pylontech batteries with Sol-Ark inverters.

Be sure to consult Pylontech’s comprehensive technical documentation for specifications and settings to ensure optimal performance and safety.

Click the link below to visit Pylontech’s website and consult their documentation.

[Pylontech documentation](#)

Communication with this battery requires a custom cable.

### Compatible Configurations Batteries Supported by the 30K-3P-208V

Battery model	Min/Max # of Modules	BMS Firmware	MBMS Firmware
PowerCube-M1-C	10S to 14S	PowerCube_M1C_CMU_V1.3	MBMS_LC_V1.4

### Batteries Supported by the 60K-3P-480V

Battery model	Min/Max # of Modules	BMS Firmware	MBMS Firmware
PowerCube-M1-C	14S to 21S	PowerCube_M1C_CMU_V1.3	MBMS_LC_V1.4

You can see the firmware version of the batteries using Pylontech’s PC software. See the manufacturer's instructions for details.

### Before you start

- See the *Pylontech Installation & Operation (I&O)* manual to set up the serial battery wiring connections and verify the proper communications configuration of CANBus connections and DIP switch settings.
- You must use a control module for a single cluster and an MBMS for two or more clusters connected in parallel. The high voltage mode requires that you connect the battery modules in series.
- Verify the firmware versions of the battery modules, control module, and MBMS. Contact Pylontech support to confirm compatibility and get necessary updates.



## Communications Installation and Setup Instructions

### Custom RJ45 cable

Create a custom RJ45 cable to establish communication between the battery and the inverter.

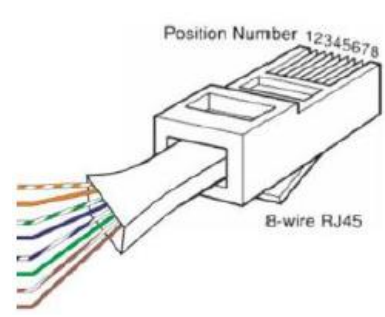
RJ45	Pin number	CAN Battery side Single and multiple clusters
	1	--
	2	GND
	3	--
	4	CANH
	5	CANL
	6	--
	7	--
	8	--

## Battery IDs and connections

3. Set the ADD Switches for the control module and MBMS (if applicable). See Pylontech's *Operation manual* for details on configuration.
4. Connect the communication cables between the battery modules and the control module.
5. Proceed with the serial connection between all the battery modules and the control module. See the *Operation manual* for startup and shutdown procedures for each battery configuration.





## Paralleling Two or More Battery Stacks

1. When paralleling two or more stacks, Pylontech requires the MBMS. Two RJ45 cables are required for this setup:
  1. **An RJ45 cable** included with the battery allows communication between battery clusters.
  2. **A custom cable** that allows communication between the MBMS and the inverter, which is the same pin configuration used for communication between the control module and the inverter when using one battery cluster.
2. Connect the cable to the **CAN 1** port on the MBMS to the **BMS1** port on the inverter.
3. Program the inverter with this battery's appropriate charge/discharge settings.
4. Enable **BMS Lithium Batt** and set its value to **00**.

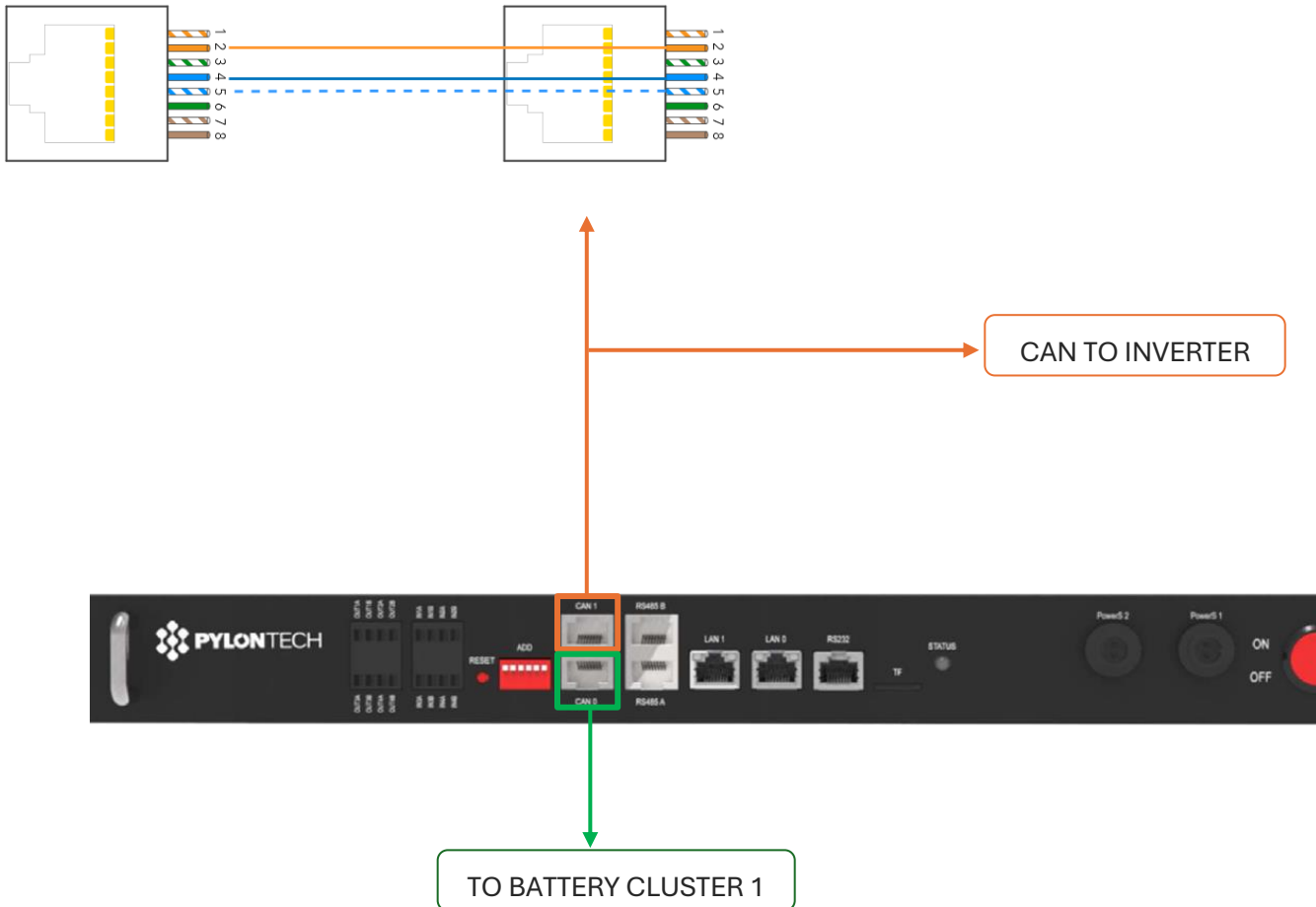



## Pytes - HV48100

Follow these instructions for setting up Pytes batteries and Sol-Ark inverters.

Be sure to consult Pytes comprehensive technical documentation for specifications and settings to ensure optimal performance and safety.

Click the link below to visit the Pytes website and consult their documentation.

[Pytes documentation](#)

Communication with this battery requires a custom cable.

### Compatible Configurations Batteries Supported by the 30K-3P-208V

Battery model	Min/Max # of Modules	BMS Firmware	HUB Firmware
HV48100	8S only	PSBCU-16S-400-V1.02.006.T5	HVHUBV1.1.1.T14

### Batteries Supported by the 60K-3P-480V

Battery model	Min/Max # of Modules	BMS Firmware	HUB Firmware
HV48100	12S only	PSBCU-16S-400-V1.02.006.T5	HVHUBV1.1.1.T14

You can see the firmware version of the batteries using Pytes PC software. See the manufacturer's instructions for details.

### Before you start

- See the Pytes User manual to proceed with the serial battery wiring connections and verify the proper communications configuration of CANBus connections and DIP switch settings.
- You must use a BCU (Battery Control Unit) for a single cluster and a 1uHub for two or more clusters connected in parallel. The high voltage mode mandates that the battery modules must be connected in series.
- Verify the firmware versions of the battery modules, BCU, and 1uHub. Contact Pytes support to confirm compatibility and obtain necessary updates.

## Communications Installation and Setup Instructions

### Custom RJ45 cable

Create a custom RJ45 cable to establish communication between the battery and the inverter.

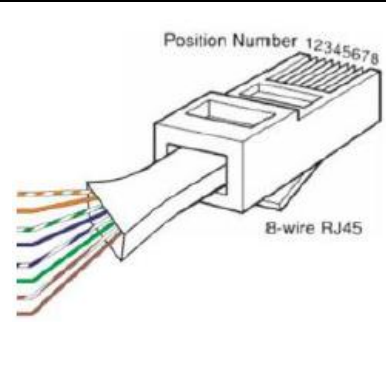
RJ45	Inverter side Pin configuration	CAN Battery side Single cluster	CAN Battery side Multiple clusters
	1	--	--
	2	--	--
	3	--	CANH
	4 CANH	CANH	CANL
	5 CANL	CANL	--
	6	--	--
	7	--	--
	8	--	--

## Battery IDs and connections

1. Set the Dip Switches for the BCU and 1uHub (if applicable). See the Pytes User manual for configuration details.
2. Connect the communication cables between the battery modules and the BCU.
3. Proceed with the serial connection between all the battery modules and the BCU. See the User manual for the correct startup and shutdown procedures for each battery configuration.

## Inverter programming and connections

### Single Battery Stack

When using a single stack, communication will be between the BCU and the inverter.

1. Connect the communication cable to the CAN port of the BCU, then connect it to the BMS1 port of the inverter.
2. Program the inverter with the appropriate Max A charge/discharge settings according to the specific battery manual and cable arrangement
3. Enable **BMS Lithium Batt** and set its value to **00**.



CAN TO INVERTER



## Paralleling Two or More Battery Stacks

1. When paralleling two or more stacks, Pytes requires the use of the 1uHub. Two RJ45 cables are required for this setup:
  - a. A standard RJ45 cable that allows communication between battery clusters.
  - b. A custom cable that allows communication between the 1uHub and the inverter.
2. Connect the cable to the CAN port on the 1uHub to the BMS1 port on the inverter.
3. Program the inverter with this battery's appropriate charge/discharge settings.
4. Enable **BMS Lithium Batt** and set its value to **00**.

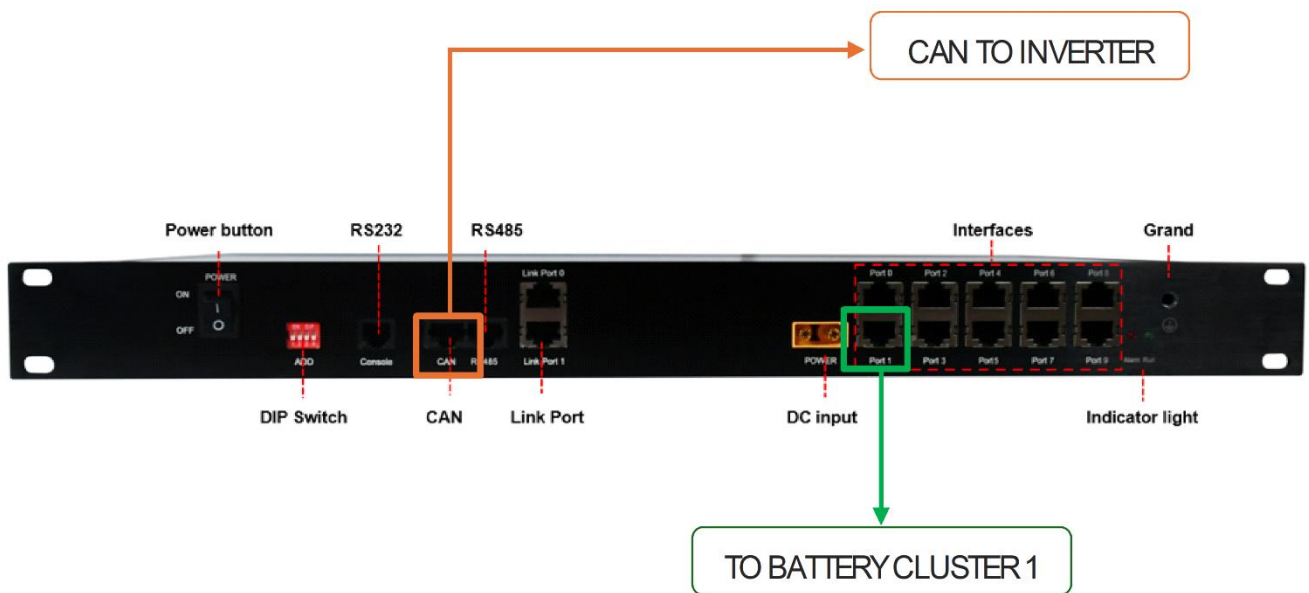



## Renon R-EC060030A1-US & R-EC060060A1-US

Follow these instructions for setting up Renon batteries with Sol-Ark inverters.

Be sure to consult Renon’s comprehensive technical documentation for specifications and settings to ensure optimal performance and safety. Click the link below.

[Renon documentation](#)

Communication with this battery requires a custom cable.

### Compatible Configurations

Renon batteries supported by the Sol-Ark 30K-3P-208V

Battery Model	Min/Max # of Modules	Supported BMS Firmware	Supported Gateway Firmware
R-EC060030A1-US	6S2P only	61kWh_6S2P_Master_13f00101_v1.000.bin	N/A

Renon batteries supported by the Sol-Ark 60K-3P-480V

Battery Model	Min/Max # of Modules	Supported BMS Firmware	Supported Gateway Firmware
R-EC060060A1-US	12S1P only	61kWh_12S1P_Master_13ee0101_v1.005	N/A

You can see the firmware version of the batteries using Renon’s PC software. See the Renon documentation for details.

### Before you start

See the Renon user manual to proceed with battery wiring connections.

- For the Sol-Ark 30K inverter, follow the instructions for serial and parallel battery wiring.
- For the Sol-Ark 60K inverter, follow the instructions for serial battery wiring.
- **Verify the configuration of the CANBus** connections for proper communication.
- **Verify the firmware versions** of the battery modules and Master Control Module. Contact Renon support to confirm compatibility and obtain necessary updates.

**WARNING:** Ecube batteries require different firmware for 60K versus 30K inverters, and Renon batteries **MUST** be wired **6S2P** with 30K inverters. Connecting a 12S1P configuration and 12S1P firmware with the Sol-Ark 30K will damage the inverter.



## Communications Installation and Setup Instructions

### Custom RJ45 cable

A custom RJ45 cable is not required. A standard RJ45 connector-based CAT5/CAT6 Ethernet cable is suitable for this application.

### Battery IDs and connections

1. Connect the communication cables between the battery modules and the control module.
2. Proceed with the serial connection between all battery modules and the control module. See the Operation manual for the correct startup and shutdown procedures for each battery configuration.

## Inverter programming and connections

### Single Battery Stack

When using a single stack, communication is between the Master Control Module and the inverter.

1. Connect the communication cable to the **U1** port inside the cabinet wiring area, and then connect it to the inverter's **BMS1** port.
2. Program the inverter with the appropriate **Max A charge/discharge** settings according to the specific battery manual and cable arrangement.
3. Enable **BMS Lithium Batt** and set its value to **00**.

**NOTE.** This integration was performed with a single battery stack. If you plan to use two or more battery stacks in a parallel configuration, we strongly recommend contacting Renon for detailed guidance to ensure optimal performance and safety.



## Disclaimer

This Battery Integration Guide is provided “as is,” without charge, and is intended solely for general informational purposes without any right or presumption of reliance. Sol-Ark does not guarantee the results obtained by use of this battery integration guide nor does Sol-Ark provide any warranty, whether express, implied or statutory, including warranties of merchantability, quality, fitness for a particular purpose, title, non-infringement of intellectual property rights, accuracy, system integration, timeliness or satisfactory quality, regarding any product other than sol-ark manufactured products. Sol-Ark is not responsible, and offers no warranty, for, or with respect to, any battery product that is not manufactured by Sol-Ark.

Your sole and exclusive remedy for any defects, or other issues associated with, or related to, a battery product is limited and restricted solely to the manufacturer warranty provided by the manufacturer of that battery. Modifications, updates, or other changes made by the battery manufacturer to a battery product, including firmware, software or hardware modifications, updates or other changes, may affect information provided in this battery integration guide and may make it inapplicable. Any of those modifications, updates or other changes may also adversely affect use of the proposed battery with Sol-Ark products or may make any integration impractical, inadvisable or improper. You are solely responsible for any integration and should confirm with the battery manufacturer that no such modifications, updates or other changes have been made by the battery manufacturer.

This Battery Integration Guide assumes the accuracy and completeness of information made available to Sol-Ark as of the effective date on the first page of this guide, and Sol-Ark assumes no responsibility if that information was inaccurate or incomplete in any respect or if that information changes in any way after the effective date (including through software updates). This battery integration guide is not intended to, and does not, supersede any instructions or directions that you may have received from the manufacturer of the battery, and is only intended to supplement those instructions or directions. Sol-Ark is not liable for any damages resulting from your use of this battery integration guide and, to the fullest extent permitted by applicable law, hereby expressly and unconditionally disclaims liability for any and all indirect, incidental, exemplary, punitive or consequential damages.

If you are uncertain about implementing or using any of the information contained in, or made available by, this Guide, you are urged not to continue with this Guide and immediately to contact the Battery manufacturer or Sol-Ark product support. This Guide does not modify, extend or change the terms of any warranty that may be applicable to your Sol-Ark products, and you should carefully consult those warranty terms to ensure that you may not be voiding or violating those warranty terms if you undertake any of the actions referred to in this Guide. In addition, you should never undertake or engage in any integration, repair or evaluation process unless and until your product has been fully and completely powered down and you have confirmed that the product is not charged in any manner.



Any action related to the information included in this Guide shall be governed by the internal laws of the State of Texas, United States of America, without giving effect to any conflicts of laws principles. Any action, suit, or other legal proceeding that is commenced to resolve any matter related to this Guide shall be commenced solely and exclusively in a state court sitting in Collin County, Texas (or, if appropriate, a federal court located within Collin County in the Eastern District of Texas), and you hereby consent to the personal jurisdiction of those courts.

**Please Note:** Sol-Ark does not offer technical support related to battery communications for battery models not specifically listed in this Guide or for batteries with respect to which modifications, updates, or other changes have been made, as noted above, after the Effective Date of this Guide.

Sol-Ark assumes no responsibility for any of those modifications, updates, or other changes or to inform itself of any of those modifications, updates, or other changes. Damage caused to a Sol-Ark product as the result of the use or integration of battery communications that are not supported by Sol-Ark will void the warranty on your Sol-Ark product.<sup>1</sup>

This Guide is intended solely for **High-Voltage Hybrid Sol-Ark Inverters** and should not be used or referenced for any other types of Sol-Ark inverters.

<sup>1</sup>Trademarks, logos, and tradenames of battery partners have been used under license and with permission and are subject to copyright by the owners thereof. Any information regarding battery performance, installation, or other matters regarding integration and documentation used in this Guide has been provided to Sol-Ark by the manufacturer, and Sol-Ark has relied on the accuracy and completeness of that information and documentation. Sol-Ark assumes no responsibility to update this Guide to reflect any modifications, updates, or changes to the information and documentation provided by any battery manufacturer, and you are urged to refer to the most recent information and documentation made available by any battery manufacturer before installing or integrating a battery product.