

## UNIRAC TECHNICAL BULLETIN

**Bulletin Number:** TB-121030-1445-1

**Theme:** SolarMount and SOLARMOUNT-E Tilt Leg FAQ's

**Background:** Unirac's technical support department often receives inquiries concerning the use of tilt legs on SolarMount and SOLARMOUNT-E. These assemblies have many factors to consider depending on your application. This technical bulletin offers some useful tips and recommendations for their application.

**Description:** There are 2 basic configurations in which modules can be mounted for tilted applications. The most common is referred to as "Low Profile Tilt" (**Figure 1**) where rails run across the tilted modules. The other is "High Profile Tilt" (**Figure 2**) where rails run up and down the tilted modules.



**Figure 1: Low Profile Tilt**



**Figure 2: High Profile Tilt**

**SOLARMOUNT-E** can be used for Low and High Profile Tilt applications on flat roofs (under 5° roof pitch) as well as flush to roof applications on pitched roofs. At the time of this writing, the SOLARMOUNT-E online configurator can address flush to roof applications on pitched roofs or Low Profile Tilt applications on flat roofs.

Some applications are outside the scope of our calculations and would need to be addressed by a 3<sup>rd</sup> party structural engineer who can design and sign off on them. These applications include:

- All High Profile applications of **SOLARMOUNT-E**.
- Low and High Profile **SOLARMOUNT-E** applications on pitched roofs.

**SolarMount Standard** is within our design guidelines for use on Low and High Profile applications on both **flat and pitched** roofs. Our online configurators currently address Low Profile Tilt applications on flat roofs and flush to roof applications on pitched roofs. SolarMount High Profile Tilt applications need to be addressed by submitting an eQuestionnaire to our Applications Engineering department here: <http://www.unirac.com/configurators/equestionnaire>

Please Note: We do not support reverse tilt applications (south facing modules mounted on north facing roofs) for any of our products. Please see the online Technical Bulletin (linked to here: [1540-0 Reverse Tilt Applicability](#)) for more details.

## UNIRAC TECHNICAL BULLETIN

Frequent questions are answered below regarding Low and then High Profile tilted module applications:

### Low Profile Tilt FAQ's:

1) Question: Where on the module frame can the rail be clamped?

Answer: The module manufacturer's installation specifications define where modules can be clamped to rails. These distances can vary by manufacturer and usually allow a range along the module edge that can be clamped to. Notice in **Figure 3** below that the leading edge of the module has the rail closer to the end of the module (**Dim A**) in order to allow module clearance off the roof surface. The trailing edge of the module has the rail that the tilt legs are attached to positioned further inboard (**Dim B**). These variances are acceptable as long as they are within the module manufacturer's installation guidelines specific to the module being installed. Be aware that the location of the front rail (**Dim A**) can sometimes limit the module tilt angle unless a standoff is used to raise the front roof attachment away from the roof surface.

2) Question: What is the correct position of the rear tilt leg? Is it ok for it to be vertical or pitched in towards the front of the array?

Answer:

- For SOLARMOUNT-E: The correct **Angle of the tilt leg from the Module** is 90° as shown in **Figure 3** below.

- For SolarMount: The tilt leg angle varies depending on the spacing between the front and rear lower attachments. Ideally, the center to center distance from the south to north rail should equal the **South to North Distance Between Attachments** shown at the bottom of **Figure 3**. Remember to comply with module manufacturer clamping requirements per Question 1 above. A vertical leg orientation is acceptable, but do not allow the bottom of the tilt legs for any application to be angled inboard towards the front of the array.

3) Question: Can I cut the tilt legs to get the module tilt angle I want?

Answer: Yes, tilt legs can be field cut and re-drilled to accommodate the preferred angle for the application.

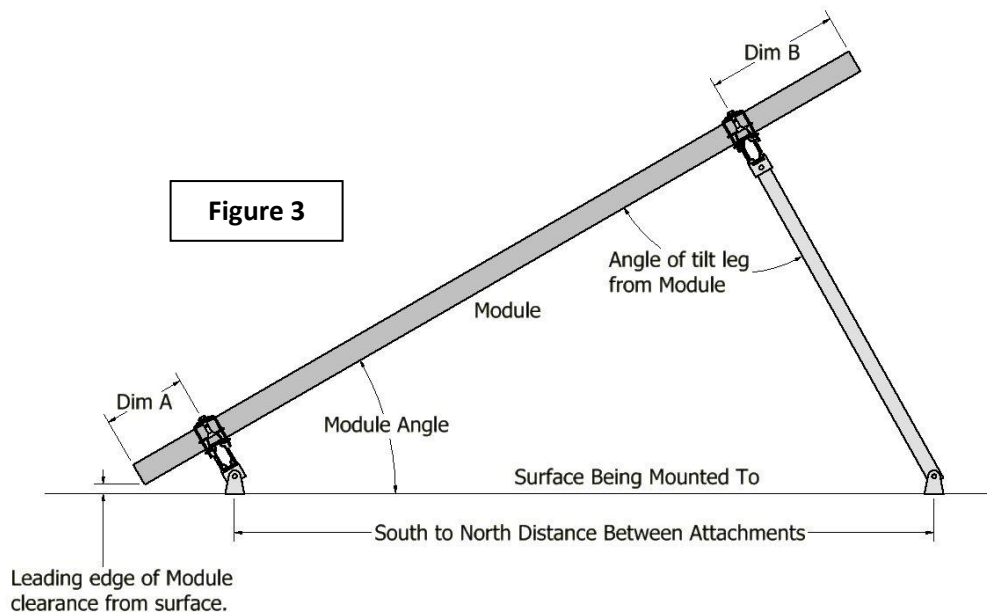

## UNIRAC TECHNICAL BULLETIN

### High Profile Tilt FAQ's:

Though High Profile applications are less common than Low Profile, there are a few common questions we receive regarding them:

1) Question: What is the maximum length of rail that can be used for High Profile applications? Can they be spliced?

Answer: Our current maximum rail length is 240 inches, which can be used on some High Profile applications depending on the design loads at the installation location. A Unirac Applications Engineer would need to confirm the maximum rail length specific to the application. Do not splice rails in any High Profile application.

2) Question: What length of the rail can be used before a middle tilt leg needs to be added to support the center of the rail?

Answer: The necessity for adding middle tilt legs to support the mid-section of the rail is driven by the length of the rail and the design loads relevant to the installation locale. In many cases it is better to support the mid-section of the rail with a tilt leg, especially for long rail lengths and a greater numbers of modules. Again, a Unirac Applications Engineer can confirm whether a middle tilt leg is needed.

3) Question: What is the maximum overhang of rail allowed past each rear tilt leg?

Answer: This length (**Dim A** in **Figure 4** below) is approximately 15% of the **Single Rail Length**.

